

Proposal Basic Information

Proposal File No.	SNPC/BP/0021/W01/2020
Owner Name	KALA MAHATO
Khata No	19
Plot No	49
Village Name	Sundarpur
Use	Residential
SubUse	Other Residential Building

AREA STATEMENT SARAIKELLA NAGAR PANCHAYAT	VERSION NO.: 1.0.46 VERSION DATE: 22/06/2020
PROJECT DETAIL:	
Region: JHARKHAND URBAN LOCAL BODIES	Plot Use: Residential
District: SERAIKELLA	Plot SubUse: Other Residential Building
Authority: SARAIKELLA NAGAR PANCHAYAT	Plot/Nearby/Religious Structure: NA
Inward No: SNPC/BP/0021/W01/2020	Plot/SubPlot No: 49
Application Type: General Proposal	North: Survey No. - PURNOCHANDRA SARANGHI
Project Type: Building Permission	South: Survey No. - ANJALI MAHATO
Nature of Development: New	East: Survey No. - SUKRA MAHATO
Location of Development Area: Old Area	West: Road Width - 3.05
AREA DETAILS:	
AREA OF PLOT (Minimum)	(A) 233.69 SQ.MT.
Deduction for NetPlot Area	
Surrender Free of Cost	3.26
Total	3.26
NET AREA OF PLOT(Gross Plot Area - Deduction from Gross Plot area)	(A-Deductions) 230.44
Deduction for Balance Plot Area(from Gross Plot Area)	
Surrender Free of Cost	3.26
Common Plot	14.01
Total	17.26
BALANCE AREA OF PLOT(Net Plot Area- Recreational/Amenity space)	(A-Deductions) 216.43
PLOT AREA FOR COVERAGE(Net Plot Area)	(A-Deductions) 230.44
Plot Area for FAR (Net Plot Area + RoadWidening Area)	(A-Deductions) 233.69
COVERAGE CHECK	
Permissible Coverage area ( 70.00 % )	161.31
Proposed Coverage Area ( 49.29 % )	113.59
Total Prop. Coverage Area ( 49.29 % )	113.59
Balance coverage area ( 20.71 % )	47.72
FAR CHECK	
Perm. FAR Area ( 1.20 )	280.43
Total Perm. FAR area	280.43
Residential FAR	113.59
Proposed FAR Area	113.59
Total Proposed FAR Area	113.59
Consumed FAR (Factor)	0.49
Balance FAR Area	166.84
BUILT UP AREA CHECK	
Total Proposed BuiltUp Area	113.59
ARCHITECT (Regd)	DURGA PRASAD DUBEY
ENGINEER (Regd)	
SUPERVISOR (Regd)	
OWNER (Regd)	KALA MAHATO
DEVELOPMENT AUTHORITY	LOCAL BODY

COLOR INDEX	
PLOT BOUNDARY	Black
ABUTTING ROAD	Green
PROPOSED CONSTRUCTION	Red
COMMON PLOT	Yellow
ROAD WIDENING AREA	Blue
EXISTING (To be retained)	Light Blue
EXISTING (To be demolished)	Orange

Buildingwise Floor FAR Details

Floor Name	Building Name		Total	
	Proposed Built Up Area (Sq.mt.)	Proposed FAR Area (Sq.mt.)	Total Proposed Built Up Area (Sq.mt.)	Total FAR Area (Sq.mt.)
Ground Floor	113.59	113.59	113.59	113.59
Terrace Floor	0.00	0.00	0.00	0.00
Total :	113.59	113.59	113.59	113.59

Building USE/SUBUSE Details

Building Name	Building Use	Building SubUse	Building Structure
A (RESIDENTIAL)	Residential	Bungalow/ Dwelling / Non Apartment	Non-Highrise

FAR & Tenement Details (Table 4c-1)

Building	No. of Same Bldg	Total Built Up Area (Sq.mt.)	Proposed FAR Area (Sq.mt.)	Total FAR Area (Sq.mt.)	Total Consumed Additional FAR Area (Sq.mt.)	Tnmt (No.)
A (RESIDENTIAL)	1	113.59	113.59	113.59	113.59	01
Grand Total :		113.59	113.59	113.59	113.59	01

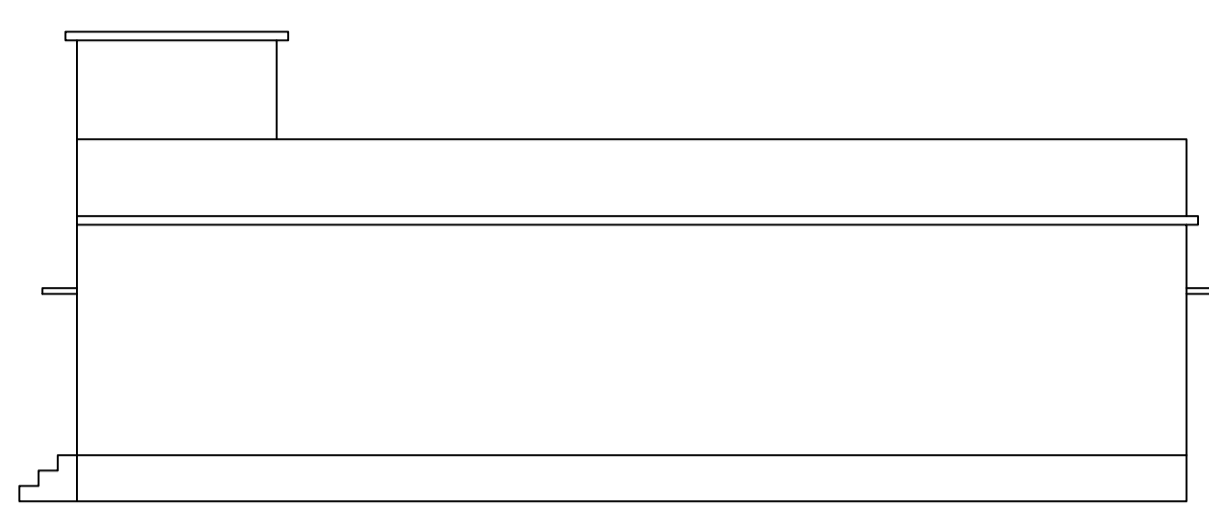
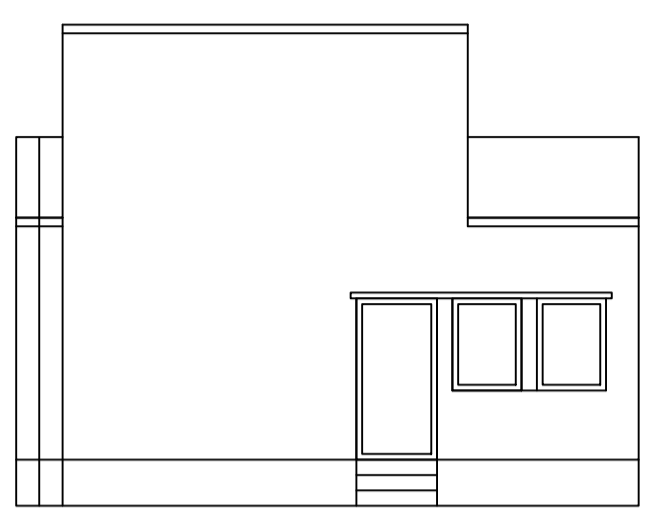
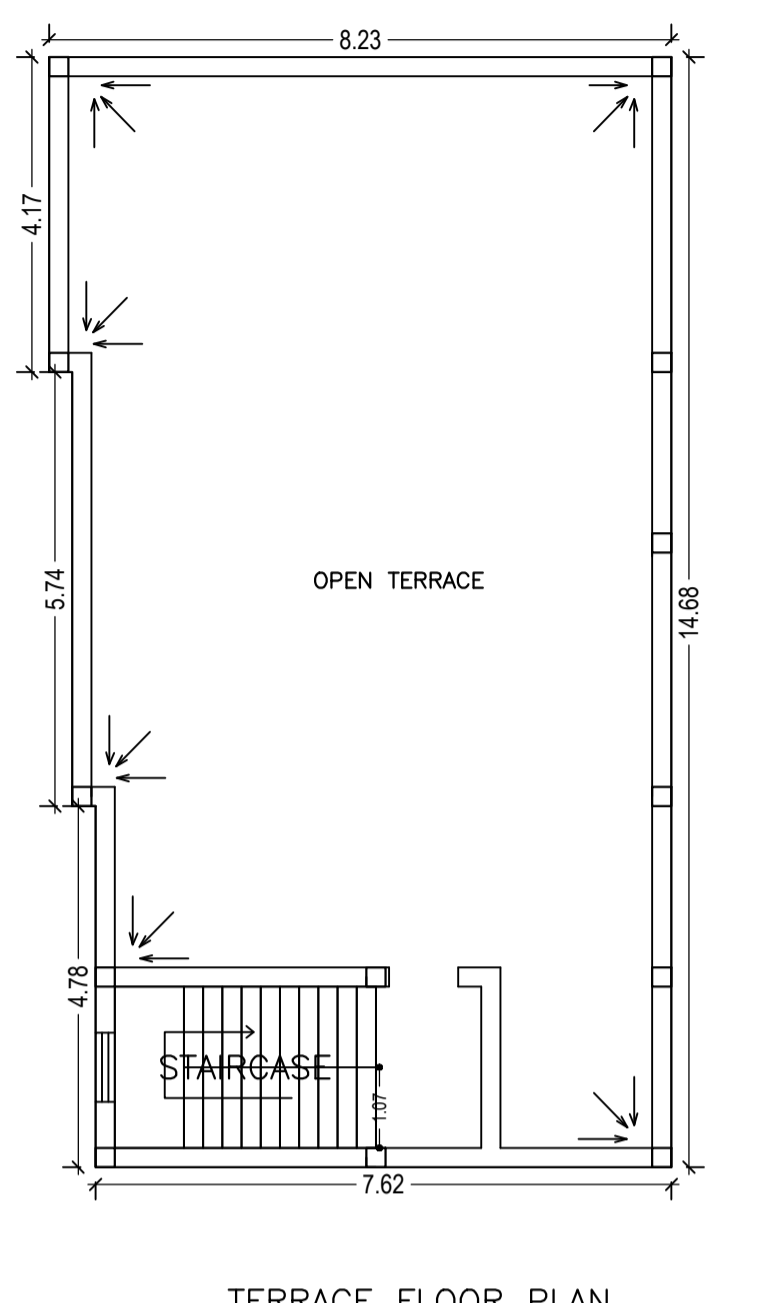
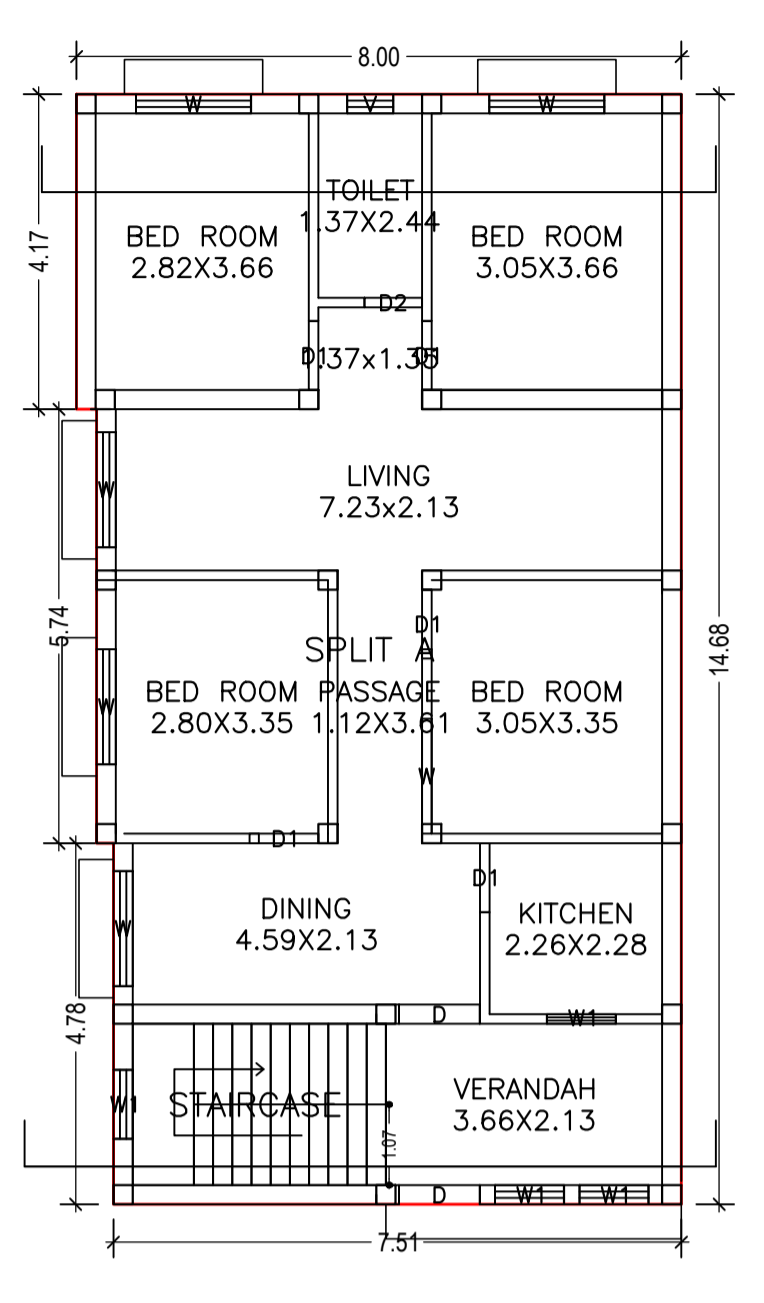
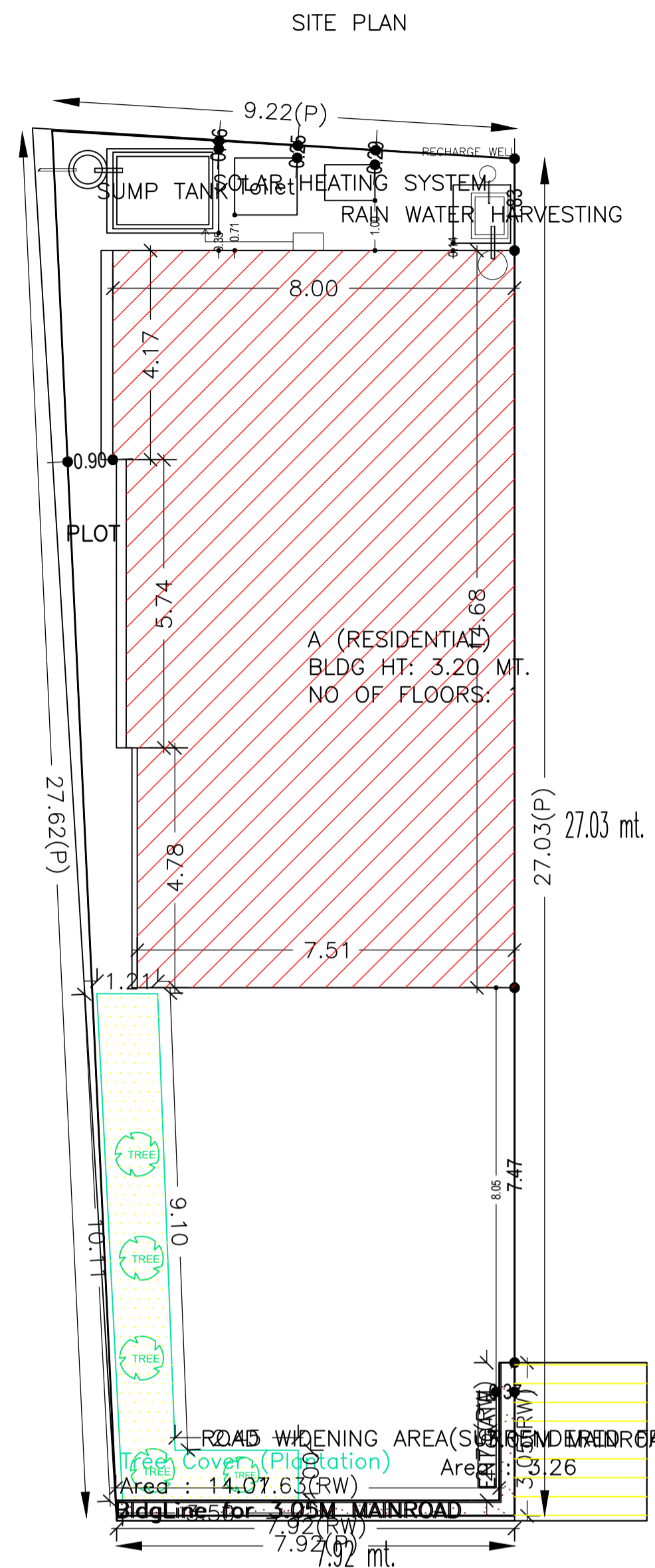

LOCATION PLAN NOT TO SCALE

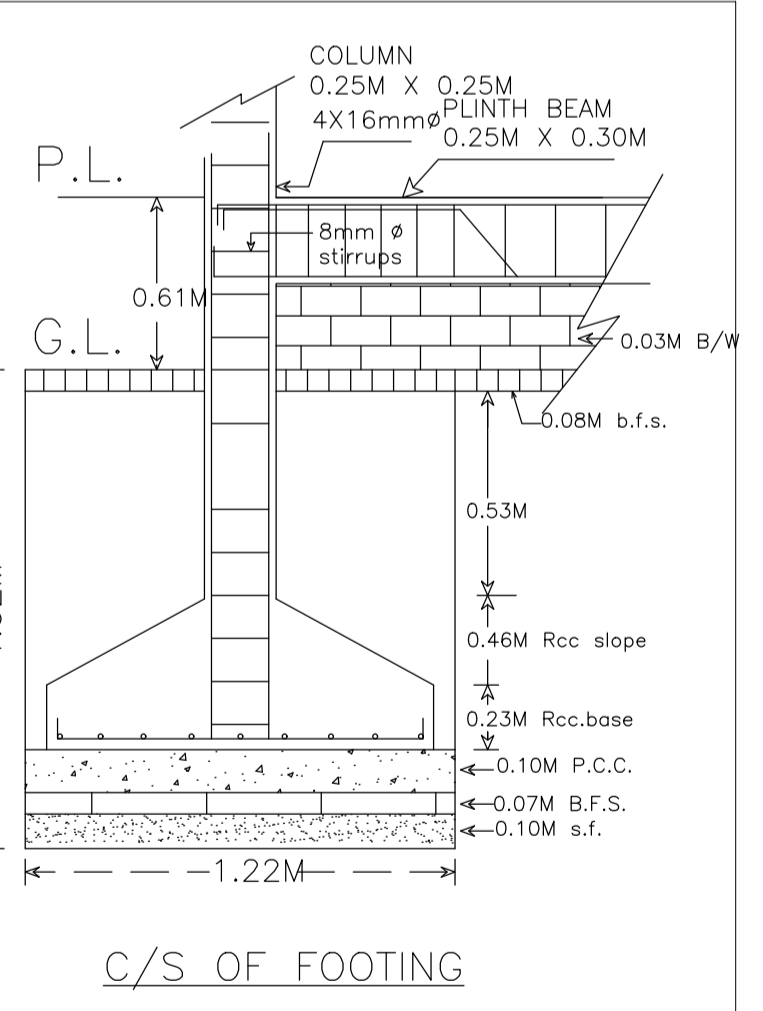
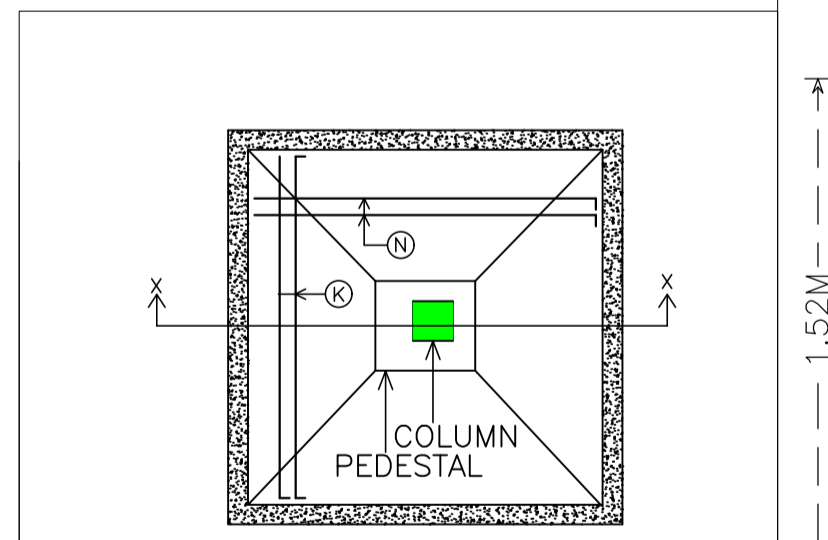
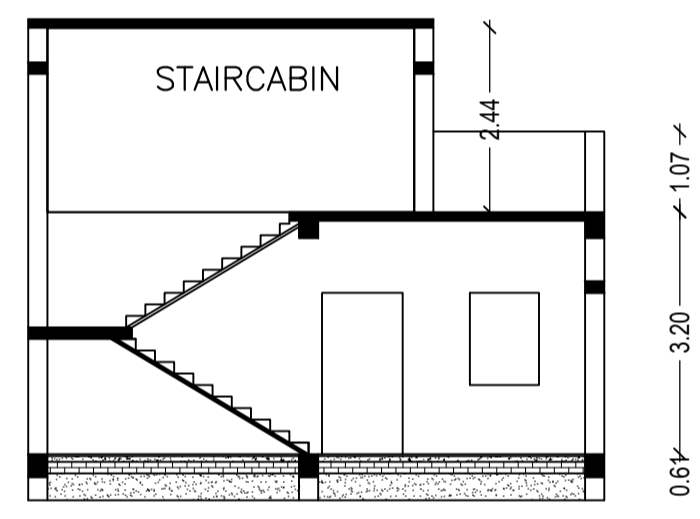
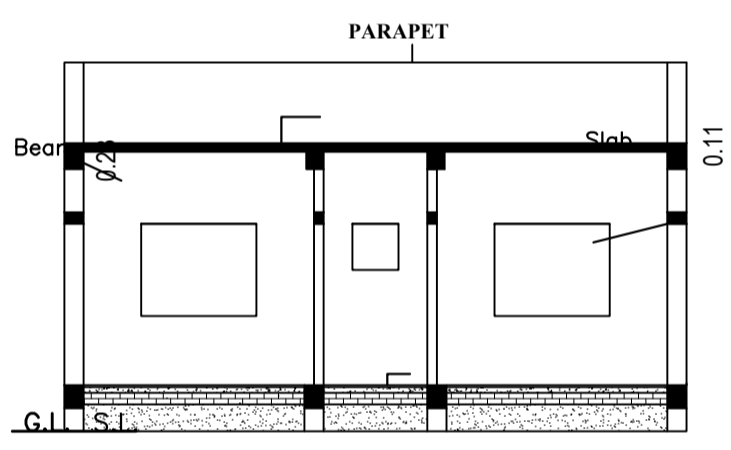
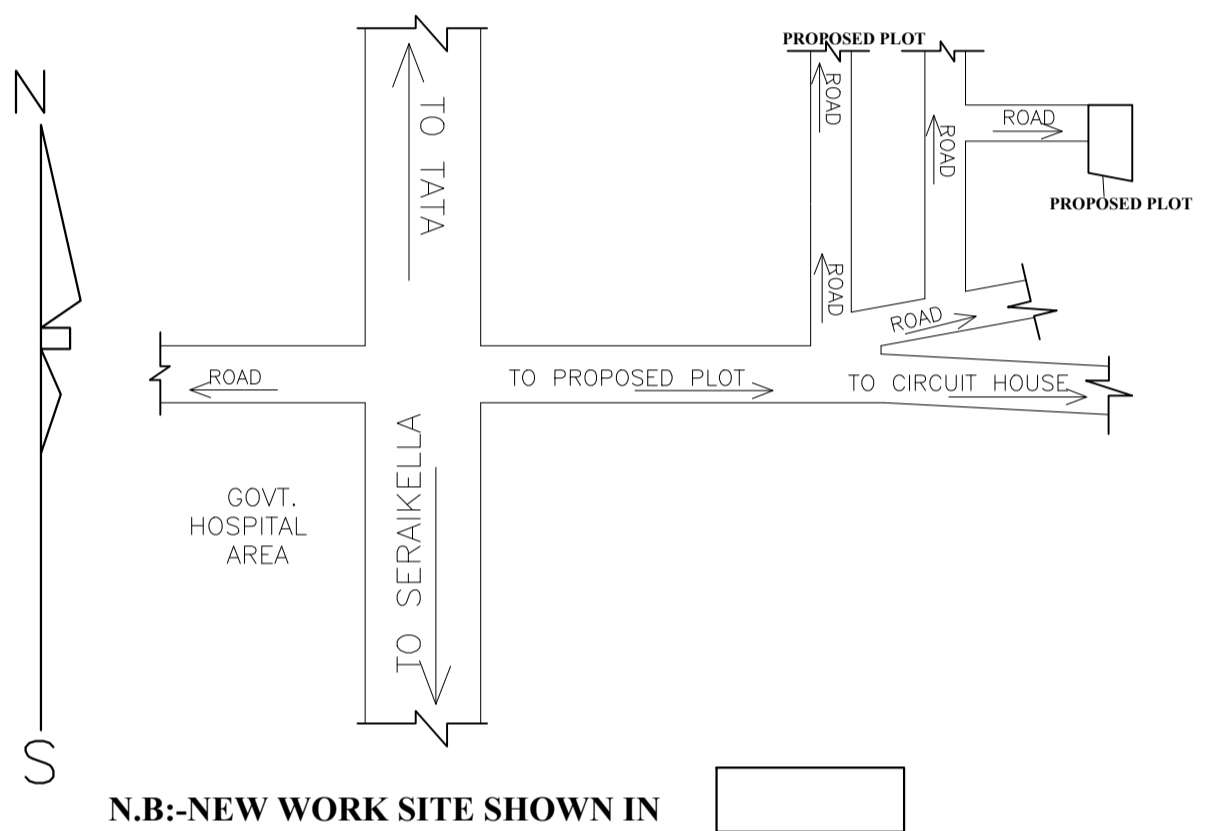

MOUZA PLAN NOT TO SCALE

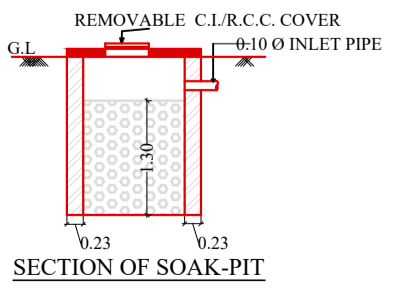
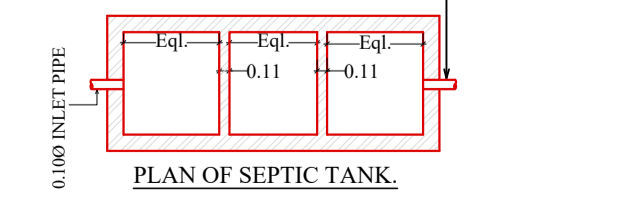
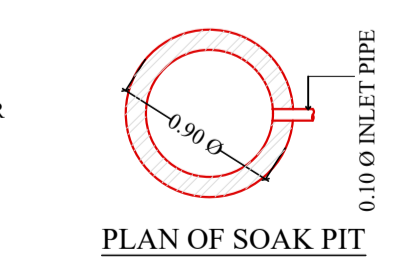
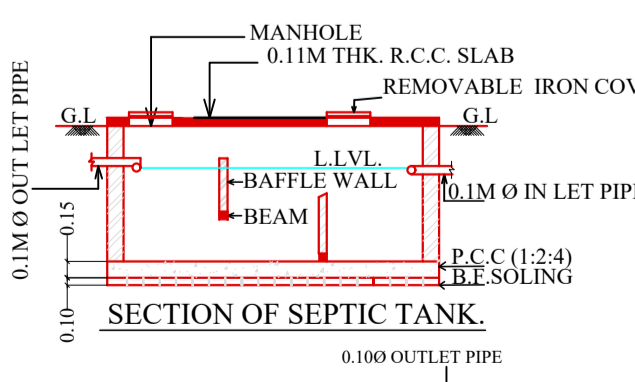
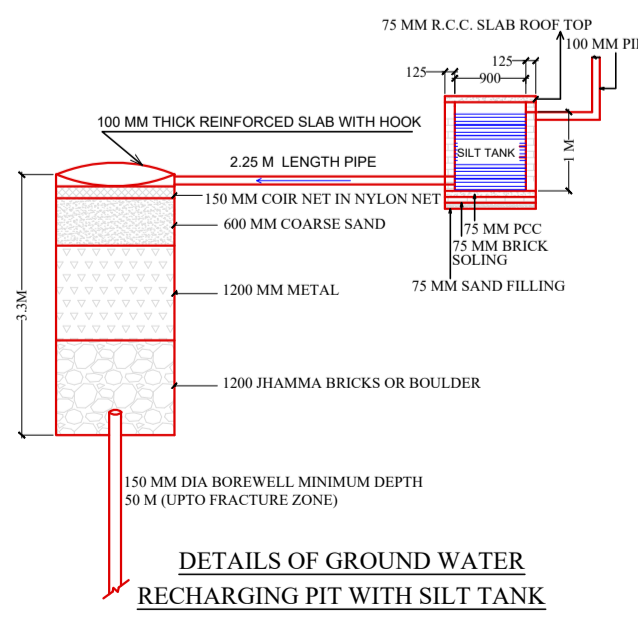
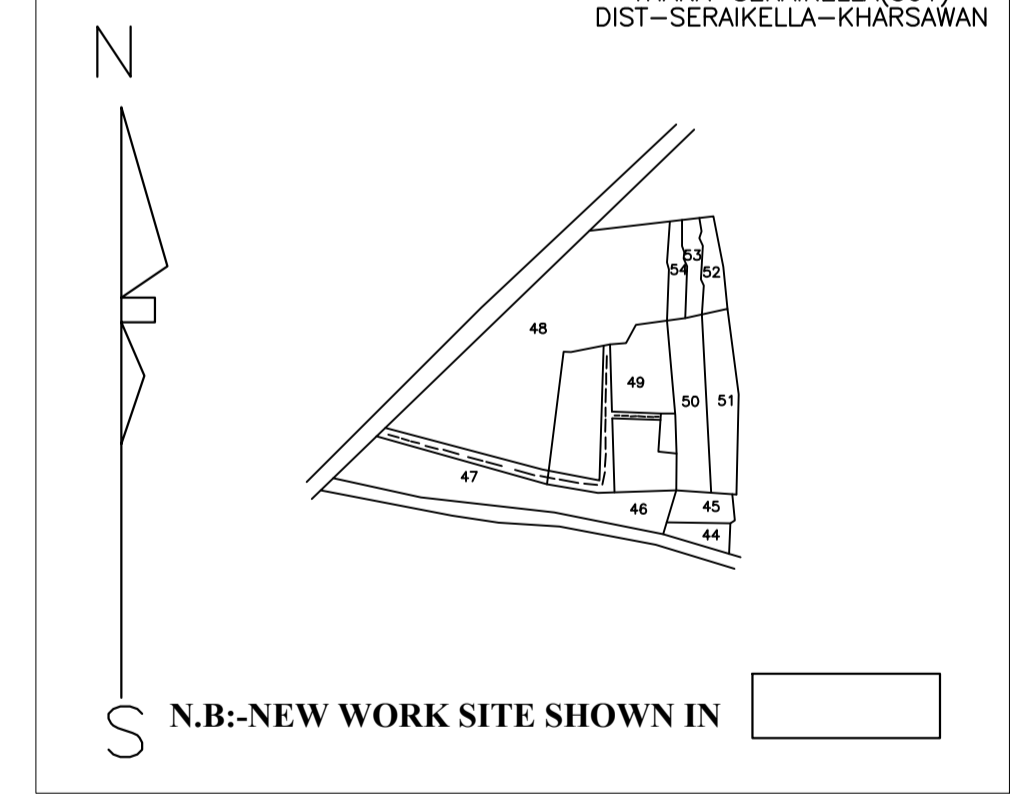

SCHEDULE OF DOOR:

BUILDING NAME	NAME	LENGTH	HEIGHT	NOS
A (RESIDENTIAL)	D2	0.76	2.10	01
A (RESIDENTIAL)	D1	0.91	2.10	05
A (RESIDENTIAL)	D	1.07	2.10	02

SCHEDULE OF WINDOW/VENTILATION:

BUILDING NAME	NAME	LENGTH	HEIGHT	NOS
A (RESIDENTIAL)	V	0.61	0.61	01
A (RESIDENTIAL)	W1	0.91	1.20	04
A (RESIDENTIAL)	W	1.52	1.20	06

UnitBUA Table for Building :A (RESIDENTIAL)

FLOOR	Name	UnitBUA Type	UnitBUA Area	Carpet Area	No. of Rooms	No. of Tenement
GROUND FLOOR PLAN	SPLIT A	FLAT	94.36	93.55	10	1
Total:			94.36	93.55	10	1

Building :A (RESIDENTIAL)

Floor Name	Total Built Up Area (Sq.mt.)	Proposed FAR Area (Sq.mt.)	Total FAR Area (Sq.mt.)	Total Consumed Additional FAR Area (Sq.mt.)	Tnmt (No.)
Ground Floor	113.59	113.59	113.59	113.59	01
Terrace Floor	0.00	0.00	0.00	0.00	00
Total :	113.59	113.59	113.59	113.59	01
Total Number of Same Buildings :	1				
Total :	113.59	113.59	113.59	113.59	01

LTP NAME AND SIGNATURE	STRUCTURAL ENG'S NAME AND SIGNATURE	BUILDER NAME AND SIGNATURE	DIGITAL SIGNATURE
DURGA PRASAD DUBEY SNPC/ENG/0004/2017			