

Project Title :SUDHA DEVI

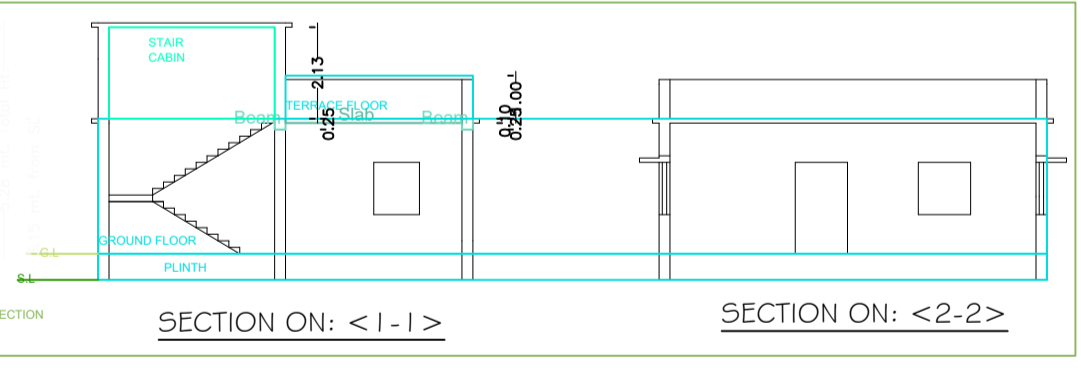
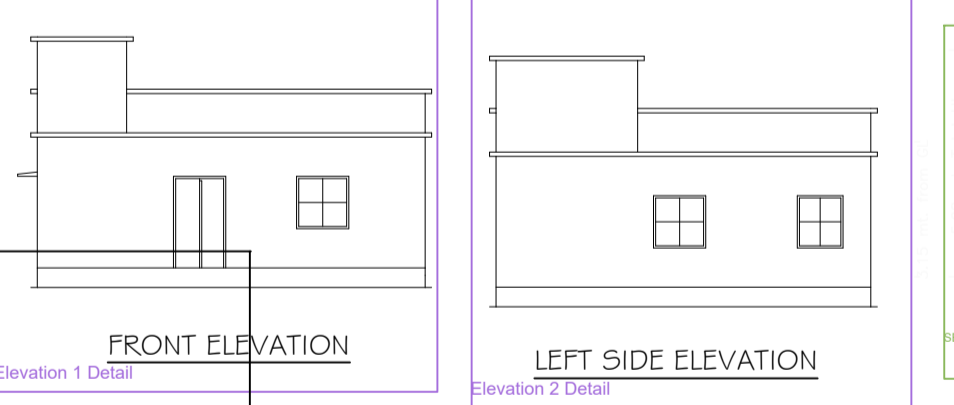
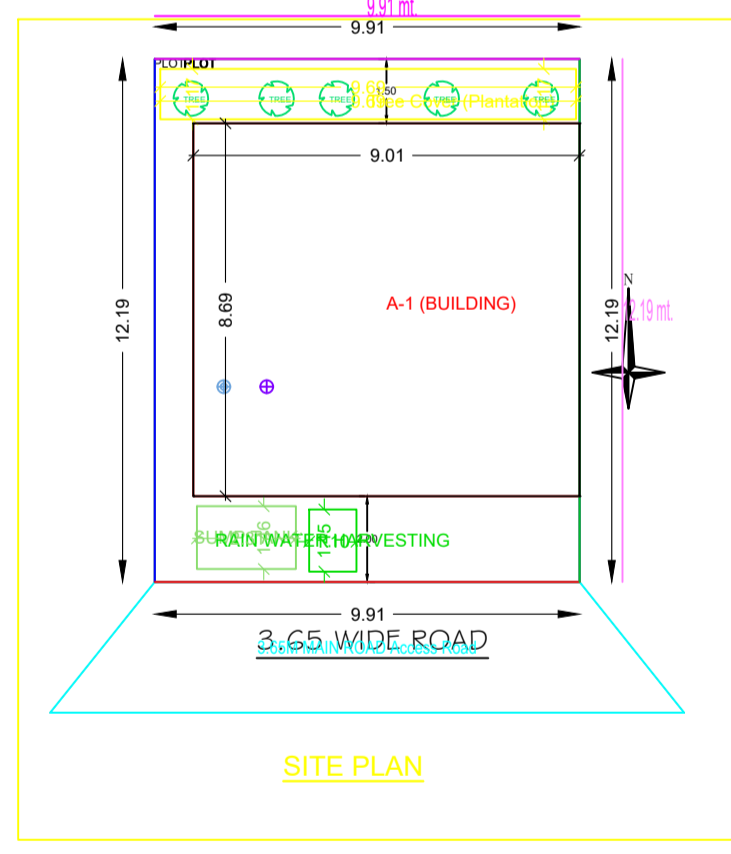
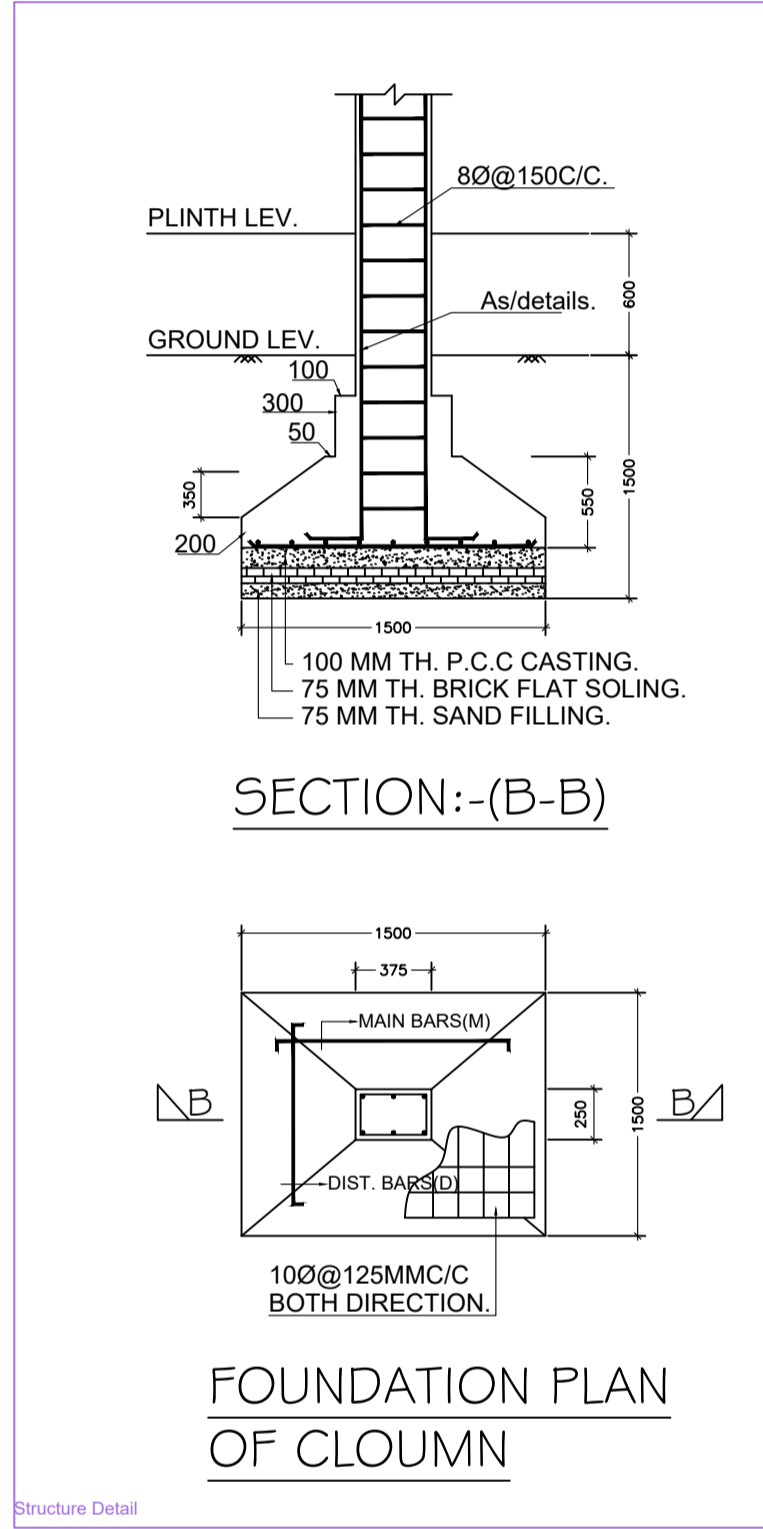
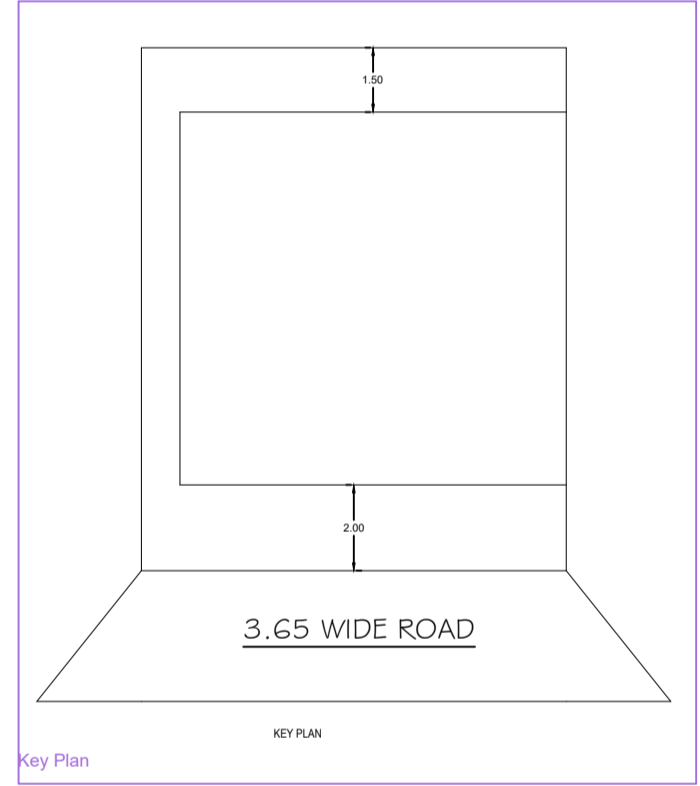
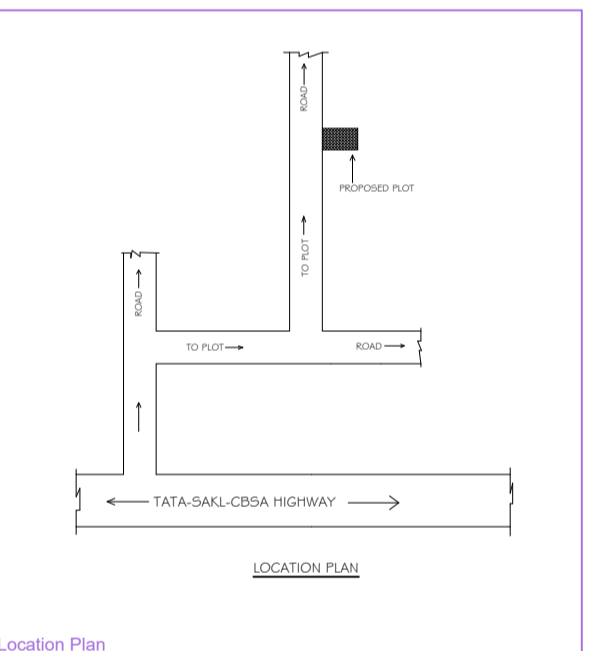
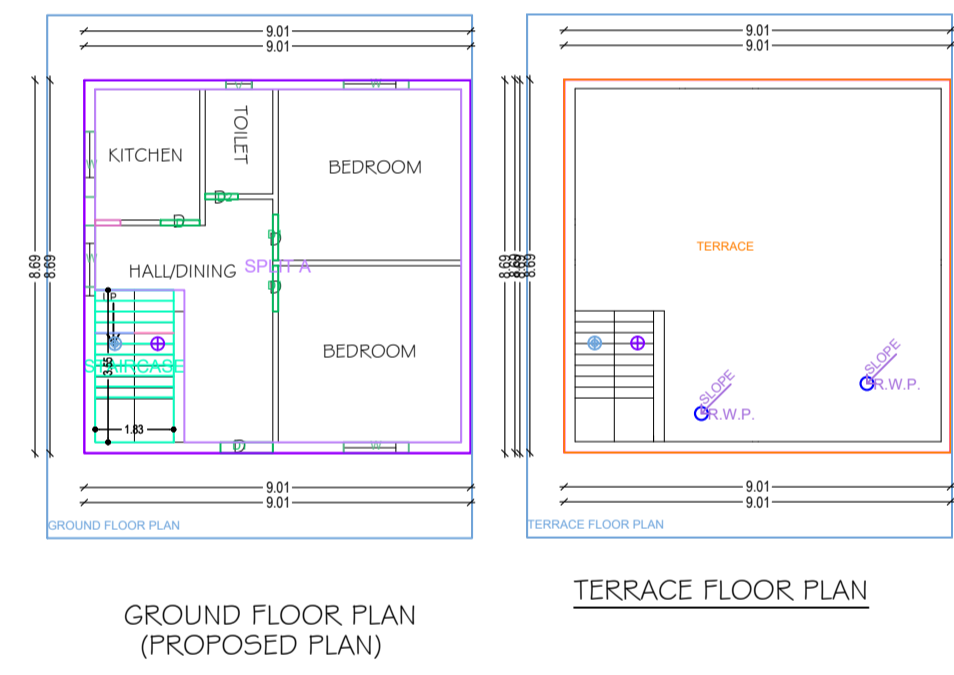
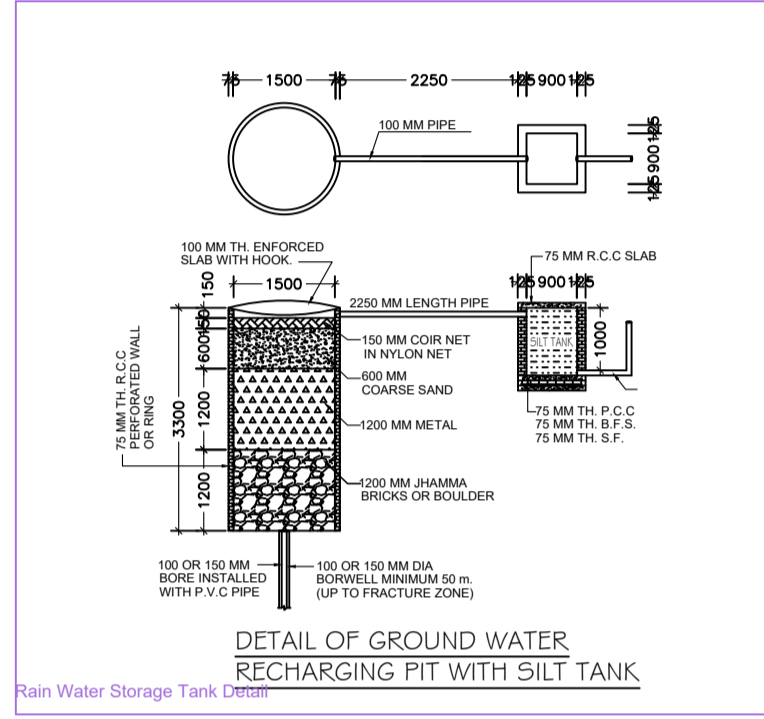
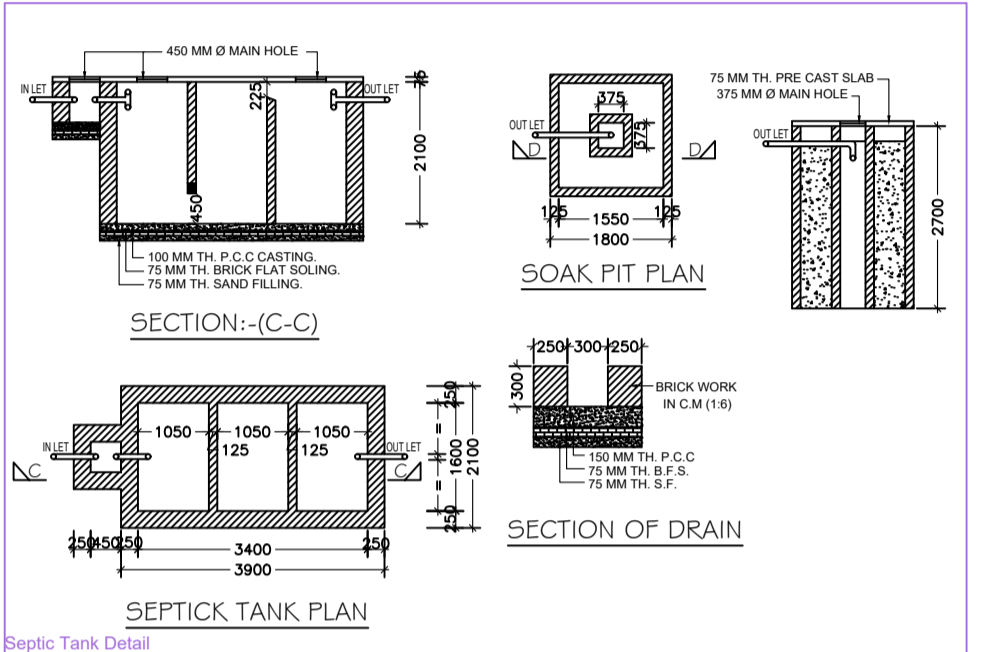

SIGN. WITH SEAL BY AUTH. AUTHORITY

AREA STATEMENT: SARAIKELANGAR, VERSION NO.: 1.0.01, VERSION DATE: 16/10/2020

PROJECT DETAILS: PROJECT NO.: 19/2020/SARAIKELANGAR LOCAL BODIES, PROJECT NAME: SOMA GODSORA S/O, LAND UNDER MOUZA: -, WARD NO.: 02, UNDER PLOT NO-143/A KHATA NO.-10, THANA NO-301, HOLDING NO- P.S.- SERAIKELLA, DISTRICT :- SERAIKELLA, JHARKHAND.

AREA DETAILS: AREA OF PLOT (Minimum): 01, AREA OF PLOT (Maximum): 01, Net Plot Area (Gross Plot Area): 126.77, Deduction from Gross Plot Area: 0.00, Deduction for Various Plot Area: 0.00, COP Area: 11.38, GOF: 12.24, Balance Plot Area (Net Plot Area): 113.29, POC Area by Coverage Rule: 126.77, POC Area for FSI Rule: 126.77, Coverage Check: Proposed Coverage (M/G): 78.28, Total Coverage Area (M/G): 78.28, FAR CHECK: Proposed FAR: 78.28, Total FAR: 78.28, ARCHT/ENGR/SUPERVISOR (Regd): OWNER, DEVELOPMENT AUTHORITY: LOCAL BODY

COLOR INDEX: PROPOSED WORK COVERAGE AREA (Green), EXISTING (In-situ) (Yellow), EXISTING (To be demolished) (Red)

Color Index: MARGIN DETAIL: Building Type, Road Name, Front Margin, Rear Margin, Side Margin, Setback Margin

FAR & Tenement Details (Table 4c-1):

Building No.	Total Built Up Area (Sq.M)	Proposed FAR (Sq.M)	Total FAR Area (Sq.M)	Tent (No.)
A1 BUILDING	78.28	78.28	78.28	01
Other	0.00	0.00	0.00	00
Total	78.28	78.28	78.28	01

SCHEDULE OF OPENING:

No.	Description	Size	Level
1.	ROLL SHUT R/S	6'-0"X8'-0"	15.
2.	ROLL SHUT R/S	7'-0"X8'-0"	16.
3.	COLP GATE CG	6'-0"X7'-0"	17.
4.	CG-1	7'-0"X7'-0"	18.
5.	CG-2	6'-0"X7'-0"	19.
6.	DOOR DV	6'-0"X8'-0"	20.
7.	DV-1	5'-0"X8'-0"	21.
8.	DV-2	4'-0"X8'-0"	22.
9.	DV-3	3'-0"X8'-0"	23.
10.	D	4'-0"X7'-0"	24.
11.	D1	5'-0"X7'-0"	25.
12.	D2	4'-0"X7'-0"	26.
13.	D3	3'-0"X7'-0"	27.
14.	D4	2'-0"X7'-0"	28.
15.	WINDOW WY	6'-0"X6'-0"	15.
16.	WV1	5'-0"X6'-0"	16.
17.	WV2	6'-0"X6'-0"	17.
18.	WINDOW W	6'-0"X6'-0"	18.
19.	W1	-	19.
20.	W2	-	20.
21.	W3	-	21.
22.	VENTILAT V	4'-0"X2'-0"	22.
23.	V1	4'-0"X1'-0"	23.
24.	V2	-	24.
25.	V3	-	25.
26.	CEIL LEVEL	2'-4"7"3/4"	26.
27.	LOFT LEVEL	7'-4"7"3/4"	27.
28.	ROOF LEVEL	9'-4"7"3/4"	28.

SCHEDULE OF AREA:

Category	Area (Sq.M)	Percentage
BUILT UP IN G.FLOOR	88.30	70.53
BUILT UP IN 1st FLOOR	88.30	70.53
BUILT UP IN 2nd FLOOR	0.00	0.00
BUILT UP IN 3rd FLOOR	0.00	0.00
BUILT UP IN 4th FLOOR	0.00	0.00
BUILT UP IN 5th FLOOR	0.00	0.00
BUILT UP IN 6th FLOOR	0.00	0.00
BUILT UP IN 7th FLOOR	0.00	0.00
BUILT UP IN 8th FLOOR	0.00	0.00
BUILT UP IN 9th FLOOR	0.00	0.00
BUILT UP IN 10th FLOOR	0.00	0.00
BUILT UP IN 11th FLOOR	0.00	0.00
BUILT UP IN 12th FLOOR	0.00	0.00
BUILT UP IN 13th FLOOR	0.00	0.00
BUILT UP IN 14th FLOOR	0.00	0.00
BUILT UP IN 15th FLOOR	0.00	0.00
BUILT UP IN 16th FLOOR	0.00	0.00
BUILT UP IN 17th FLOOR	0.00	0.00
BUILT UP IN 18th FLOOR	0.00	0.00
BUILT UP IN 19th FLOOR	0.00	0.00
BUILT UP IN 20th FLOOR	0.00	0.00
BUILT UP IN 21st FLOOR	0.00	0.00
BUILT UP IN 22nd FLOOR	0.00	0.00
BUILT UP IN 23rd FLOOR	0.00	0.00
BUILT UP IN 24th FLOOR	0.00	0.00
BUILT UP IN 25th FLOOR	0.00	0.00
BUILT UP IN 26th FLOOR	0.00	0.00
BUILT UP IN 27th FLOOR	0.00	0.00
BUILT UP IN 28th FLOOR	0.00	0.00
BUILT UP IN 29th FLOOR	0.00	0.00
BUILT UP IN 30th FLOOR	0.00	0.00
BUILT UP IN 31st FLOOR	0.00	0.00
BUILT UP IN 32nd FLOOR	0.00	0.00
BUILT UP IN 33rd FLOOR	0.00	0.00
BUILT UP IN 34th FLOOR	0.00	0.00
BUILT UP IN 35th FLOOR	0.00	0.00
BUILT UP IN 36th FLOOR	0.00	0.00
BUILT UP IN 37th FLOOR	0.00	0.00
BUILT UP IN 38th FLOOR	0.00	0.00
BUILT UP IN 39th FLOOR	0.00	0.00
BUILT UP IN 40th FLOOR	0.00	0.00
BUILT UP IN 41st FLOOR	0.00	0.00
BUILT UP IN 42nd FLOOR	0.00	0.00
BUILT UP IN 43rd FLOOR	0.00	0.00
BUILT UP IN 44th FLOOR	0.00	0.00
BUILT UP IN 45th FLOOR	0.00	0.00
BUILT UP IN 46th FLOOR	0.00	0.00
BUILT UP IN 47th FLOOR	0.00	0.00
BUILT UP IN 48th FLOOR	0.00	0.00
BUILT UP IN 49th FLOOR	0.00	0.00
BUILT UP IN 50th FLOOR	0.00	0.00
BUILT UP IN 51st FLOOR	0.00	0.00
BUILT UP IN 52nd FLOOR	0.00	0.00
BUILT UP IN 53rd FLOOR	0.00	0.00
BUILT UP IN 54th FLOOR	0.00	0.00
BUILT UP IN 55th FLOOR	0.00	0.00
BUILT UP IN 56th FLOOR	0.00	0.00
BUILT UP IN 57th FLOOR	0.00	0.00
BUILT UP IN 58th FLOOR	0.00	0.00
BUILT UP IN 59th FLOOR	0.00	0.00
BUILT UP IN 60th FLOOR	0.00	0.00
BUILT UP IN 61st FLOOR	0.00	0.00
BUILT UP IN 62nd FLOOR	0.00	0.00
BUILT UP IN 63rd FLOOR	0.00	0.00
BUILT UP IN 64th FLOOR	0.00	0.00
BUILT UP IN 65th FLOOR	0.00	0.00
BUILT UP IN 66th FLOOR	0.00	0.00
BUILT UP IN 67th FLOOR	0.00	0.00
BUILT UP IN 68th FLOOR	0.00	0.00
BUILT UP IN 69th FLOOR	0.00	0.00
BUILT UP IN 70th FLOOR	0.00	0.00
BUILT UP IN 71st FLOOR	0.00	0.00
BUILT UP IN 72nd FLOOR	0.00	0.00
BUILT UP IN 73rd FLOOR	0.00	0.00
BUILT UP IN 74th FLOOR	0.00	0.00
BUILT UP IN 75th FLOOR	0.00	0.00
BUILT UP IN 76th FLOOR	0.00	0.00
BUILT UP IN 77th FLOOR	0.00	0.00
BUILT UP IN 78th FLOOR	0.00	0.00
BUILT UP IN 79th FLOOR	0.00	0.00
BUILT UP IN 80th FLOOR	0.00	0.00
BUILT UP IN 81st FLOOR	0.00	0.00
BUILT UP IN 82nd FLOOR	0.00	0.00
BUILT UP IN 83rd FLOOR	0.00	0.00
BUILT UP IN 84th FLOOR	0.00	0.00
BUILT UP IN 85th FLOOR	0.00	0.00
BUILT UP IN 86th FLOOR	0.00	0.00
BUILT UP IN 87th FLOOR	0.00	0.00
BUILT UP IN 88th FLOOR	0.00	0.00
BUILT UP IN 89th FLOOR	0.00	0.00
BUILT UP IN 90th FLOOR	0.00	0.00
BUILT UP IN 91st FLOOR	0.00	0.00
BUILT UP IN 92nd FLOOR	0.00	0.00
BUILT UP IN 93rd FLOOR	0.00	0.00
BUILT UP IN 94th FLOOR	0.00	0.00
BUILT UP IN 95th FLOOR	0.00	0.00
BUILT UP IN 96th FLOOR	0.00	0.00
BUILT UP IN 97th FLOOR	0.00	0.00
BUILT UP IN 98th FLOOR	0.00	0.00
BUILT UP IN 99th FLOOR	0.00	0.00
BUILT UP IN 100th FLOOR	0.00	0.00

SCHEDULE OF JOINTS:

Building Name	Name	Length	Height	NBS
A BUILDING	01	3.75	2.10	01
A BUILDING	02	0.91	2.10	01
A BUILDING	03	1.22	2.10	01
A BUILDING	04	1.22	2.10	01
A BUILDING	05	1.22	2.10	01
A BUILDING	06	1.22	2.10	01
A BUILDING	07	1.22	2.10	01
A BUILDING	08	1.22	2.10	01
A BUILDING	09	1.22	2.10	01
A BUILDING	10	1.22	2.10	01
A BUILDING	11	1.22	2.10	01
A BUILDING	12	1.22	2.10	01
A BUILDING	13	1.22	2.10	01
A BUILDING	14	1.22	2.10	01
A BUILDING	15	1.22	2.10	01
A BUILDING	16	1.22	2.10	01
A BUILDING	17	1.22	2.10	01
A BUILDING	18	1.22	2.10	01
A BUILDING	19	1.22	2.10	01
A BUILDING	20	1.22	2.10	01
A BUILDING	21	1.22	2.10	01
A BUILDING	22	1.22	2.10	01
A BUILDING	23	1.22	2.10	01
A BUILDING	24	1.22	2.10	01
A BUILDING	25	1.22	2.10	01
A BUILDING	26	1.22	2.10	01
A BUILDING	27	1.22	2.10	01
A BUILDING	28	1.22	2.10	01
A BUILDING	29	1.22	2.10	01
A BUILDING	30	1.22	2.10	01
A BUILDING	31	1.22	2.10	01
A BUILDING	32	1.22	2.10	01
A BUILDING	33	1.22	2.10	01
A BUILDING	34	1.22	2.10	01
A BUILDING	35	1.22	2.10	01
A BUILDING	36	1.22	2.10	01
A BUILDING	37	1.22	2.10	01
A BUILDING	38	1.22	2.10	01
A BUILDING	39	1.22	2.10	01
A BUILDING	40	1.22	2.10	01
A BUILDING	41	1.22	2.10	01
A BUILDING	42	1.22	2.10	01
A BUILDING	43	1.22	2.10	01
A BUILDING	44	1.22	2.10	01
A BUILDING	45	1.22	2.10	01
A BUILDING	46	1.22	2.10	01
A BUILDING	47	1.22	2.10	01
A BUILDING	48	1.22	2.10	01
A BUILDING	49	1.22	2.10	01
A BUILDING	50	1.22	2.10	01
A BUILDING	51	1.22	2.10	01
A BUILDING	52	1.22	2.10	01
A BUILDING	53	1.22	2.10	01
A BUILDING	54	1.22	2.10	01
A BUILDING	55	1.22	2.10	01
A BUILDING	56	1.22	2.10	01
A BUILDING	57	1.22	2.10	01
A BUILDING	58	1.22	2.10	01
A BUILDING	59	1.22	2.10	01
A BUILDING	60	1.22	2.10	01
A BUILDING	61	1.22	2.10	01
A BUILDING	62	1.22	2.10	01
A BUILDING	63	1.22	2.10	01
A BUILDING	64	1.22	2.10	01
A BUILDING	65	1.22	2.10	01
A BUILDING	66	1.22	2.10	01
A BUILDING	67	1.22	2.10	01
A BUILDING	68	1.22	2.10	01
A BUILDING	69	1.22	2.10	01
A BUILDING	70	1.22	2.10	01
A BUILDING	71	1.22	2.10	01
A BUILDING	72	1.22	2.10	01
A BUILDING	73	1.22	2.10	01
A BUILDING	74	1.22	2.10	01
A BUILDING	75	1.22	2.10	01
A BUILDING	76	1.22	2.10	01
A BUILDING	77	1.22	2.10	01
A BUILDING	78	1.22	2.10	01
A BUILDING	79	1.22	2.10	01
A BUILDING	80	1.22	2.10	01
A BUILDING	81	1.22	2.10	01
A BUILDING	82	1.22	2.10	01
A BUILDING	83	1.22	2.10	01
A BUILDING	84	1.22	2.10	01
A BUILDING	85	1.22	2.10	01
A BUILDING	86	1.22	2.10	01
A BUILDING	87	1.22	2.10	01
A BUILDING	88	1.22	2.10	01
A BUILDING	89	1.22	2.10	01
A BUILDING	90	1.22	2.10	01
A BUILDING	91	1.22	2.10	01
A BUILDING	92	1.22	2.10	01
A BUILDING	93	1.22	2.10	01
A BUILDING	94	1.22	2.10	01
A BUILDING	95	1.22	2.10	01
A BUILDING	96	1.22	2.10	01
A BUILDING	97	1.22	2.10	01
A BUILDING	98	1.22	2.10	01
A BUILDING	99	1.22	2.10	01
A BUILDING	100	1.22	2.10	01

SCHEDULE OF JOINTS:

Building Name	Name	Length	Height	NBS
A BUILDING	01	3.75	2.10	01
A BUILDING	02	0.91	2.10	01
A BUILDING	03	1.22	2.10	01
A BUILDING	04	1.22	2.10	01
A BUILDING	05	1.22	2.10	01
A BUILDING	06	1.22	2.10	01
A BUILDING	07	1.22	2.10	01
A BUILDING	08	1.22	2.10	01
A BUILDING	09	1.22	2.10	01
A BUILDING	10	1.22	2.10	01
A BUILDING	11	1.22	2.10	01
A BUILDING	12	1.22	2.10	01
A BUILDING	13	1.22	2.10	01
A BUILDING	14	1.22	2.10	01
A BUILDING	15	1.22	2.10	01
A BUILDING	16	1.22	2.10	01
A BUILDING	17	1.22	2.10	01
A BUILDING	18	1.22	2.10	01
A BUILDING	19	1.22	2.10	01
A BUILDING	20	1.22	2.10	01
A BUILDING	21	1.22	2.10	01
A BUILDING	22	1.22	2.10	01
A BUILDING	23	1.22	2.10	01
A BUILDING	24	1.22	2.10	01
A BUILDING	25	1.22	2.10	01
A BUILDING	26	1.22	2.10	01
A BUILDING	27	1.22	2.10	01
A BUILDING	28	1.22	2.10	01
A BUILDING	29	1.22	2.10	01
A BUILDING	30	1.22	2.10	01
A BUILDING	31	1.22	2.10	01
A BUILDING	32	1.22	2.10	01
A BUILDING	33	1.22	2	