

UnitBUA Table for Building :1 (ASD)

FLOOR	Name	UnitBUA Type	UnitBUA Area	Carpet Area	No. of Rooms	No. of Tenement
GROUND FLOOR PLAN	SPLIT 1	FLAT	93.77	93.14	8	1
Total:	-	-	93.77	93.14	8	1

SCHEDULE OF DOOR:

BUILDING NAME	NAME	LENGTH	HEIGHT	NOS
1 (ASD)	D2	0.75	2.10	08

SCHEDULE OF WINDOW/VENTILATION:

BUILDING NAME	NAME	LENGTH	HEIGHT	NOS
1 (ASD)	V	0.60	1.20	01
1 (ASD)	W2	1.20	1.20	01
1 (ASD)	W	1.80	1.20	05

Proposal Basic Information

Proposal File No.	SNPC/BP/0022/W04/2021
Owner Name	RAJESH GUNDUA
Khata No	58
Plot No	827
Village Name	Dehuri Sai
Use	Residential
SubUse	Bungalow/ Dwelling / Non Apartment

AREA STATEMENT SARAIKELA NAGAR PANCHAYAT

VERSION NO.: 1.0.61
VERSION DATE: 16/10/2020

PROJECT DETAIL:

Region: JHARKHAND URBAN	Plot Use: Residential
LOCAL BODIES	Plot SubUse: Bungalow/ Dwelling / Non Apartment
District: SERAIKELA	PlotNearbyReligiousStructure: NA
Authority: SARAIKELA NAGAR PANCHAYAT	
Inward No: SNPC/BP/0022/W04/2021	Plot/SubPlot No: 827
Application Type: General Proposal	North Road Width - 5.5
Project Type: Building Permission	South Road No. - 827
Nature of Development: New	East Plot No. - 827
Location of Development Area: Old Area	West Plot No. - 827

AREA DETAILS:

AREA OF PLOT (Minimum)	(A)	SQ.MT.
NET AREA OF PLOT (Gross Plot Area - Deduction from Gross Plot area)	(A-Deductions)	151.28
Deduction for Balance Plot Area (from Gross Plot Area)		
Common Plot		13.40
Total		13.40
BALANCE AREA OF PLOT (Net Plot Area - Recreational/Amenity space)	(A-Deductions)	137.88
PLOT AREA FOR COVERAGE (Net Plot Area)	(A-Deductions)	151.28
Plot Area for FAR (Net Plot Area + Road Widening Area)	(A-Deductions)	151.28

COVERAGE CHECK

Permissible Coverage area (70.00 %)	105.90
Proposed Coverage Area (61.98 %)	93.77
Total Prop. Coverage Area (61.98 %)	93.77
Balance coverage area (8.02 %)	12.13

FAR CHECK

Perm. FAR Area (1.80)	272.30
Total Perm. FAR area	272.30
Residential FAR	93.77
Proposed FAR Area	93.77
Total Proposed FAR Area	93.77
Consumed FAR (Factor)	0.62
Balance FAR Area	178.53

BUILT UP AREA CHECK

Total Proposed BuiltUp Area	93.77
-----------------------------	-------

ARCHITECT (Regd) ANITA KUMARI
ENGINEER (Regd)
SUPERVISOR (Regd)
OWNER (Regd) RAJESH GUNDUA

DEVELOPMENT AUTHORITY LOCAL BODY

COLOR INDEX

PLOT BOUNDARY	Black
ABUTTING ROAD	Green
PROPOSED CONSTRUCTION	Red
COMMON PLOT	Yellow
ROAD WIDENING AREA	Blue
EXISTING (To be retained)	Light Blue
EXISTING (To be demolished)	White

Buildingwise Floor FAR Details

Floor Name	Building Name 1 (ASD)		Total	
	Proposed Built Up Area (Sq.mt.)	Proposed FAR Area (Sq.mt.)	Total Proposed Built Up Area (Sq.mt.)	Total FAR Area (Sq.mt.)
Ground Floor	93.77	93.77	93.77	93.77
Terrace Floor	0.00	0.00	0.00	0.00
Total :	93.77	93.77	93.77	93.77

Building USE/SUBUSE Details

Building Name	Building Use	Building SubUse	Building Structure
1 (ASD)	Residential	Bungalow/ Dwelling / Non Apartment	Non-Highrise

FAR & Tenement Details (Table 4c-1)

Building	No. of Same Bldg	Total Built Up Area (Sq.mt.)	Proposed FAR Area (Sq.mt.)	Total FAR Area (Sq.mt.)	Total Consumed Additional FAR Area (Sq.mt.)	Tnmt (No.)
1 (ASD)	1	93.77	93.77	93.77	93.77	01
Grand Total :	1	93.77	93.77	93.77	93.77	01

Building :1 (ASD)

Floor Name	Total Built Up Area (Sq.mt.)	Proposed FAR Area (Sq.mt.)	Total FAR Area (Sq.mt.)	Total Consumed Additional FAR Area (Sq.mt.)	Tnmt (No.)
Ground Floor	93.77	93.77	93.77	93.77	01
Terrace Floor	0.00	0.00	0.00	0.00	00
Total :	93.77	93.77	93.77	93.77	01
Total Number of Same Buildings	1				
Total :	93.77	93.77	93.77	93.77	01

SITE PLAN

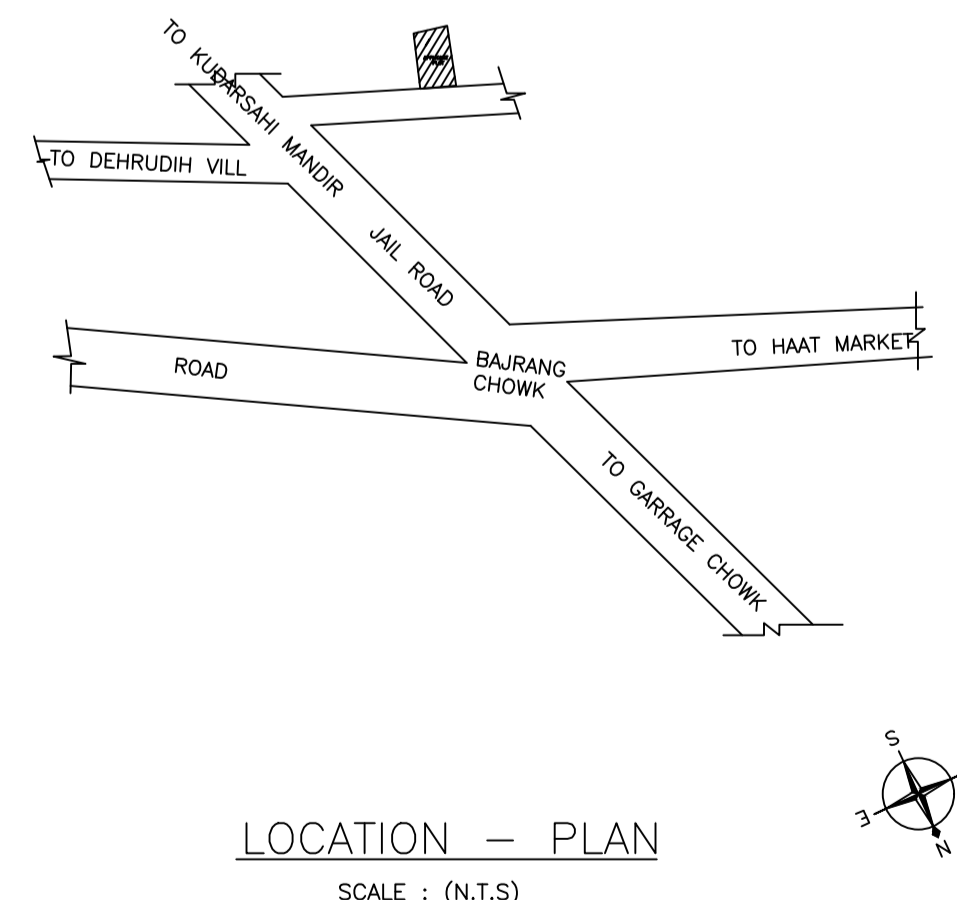
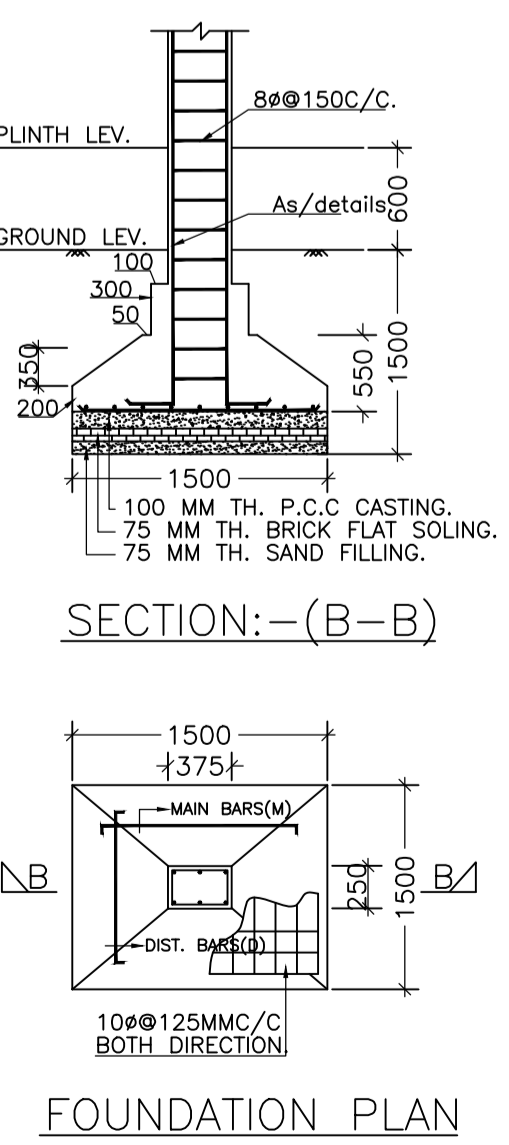
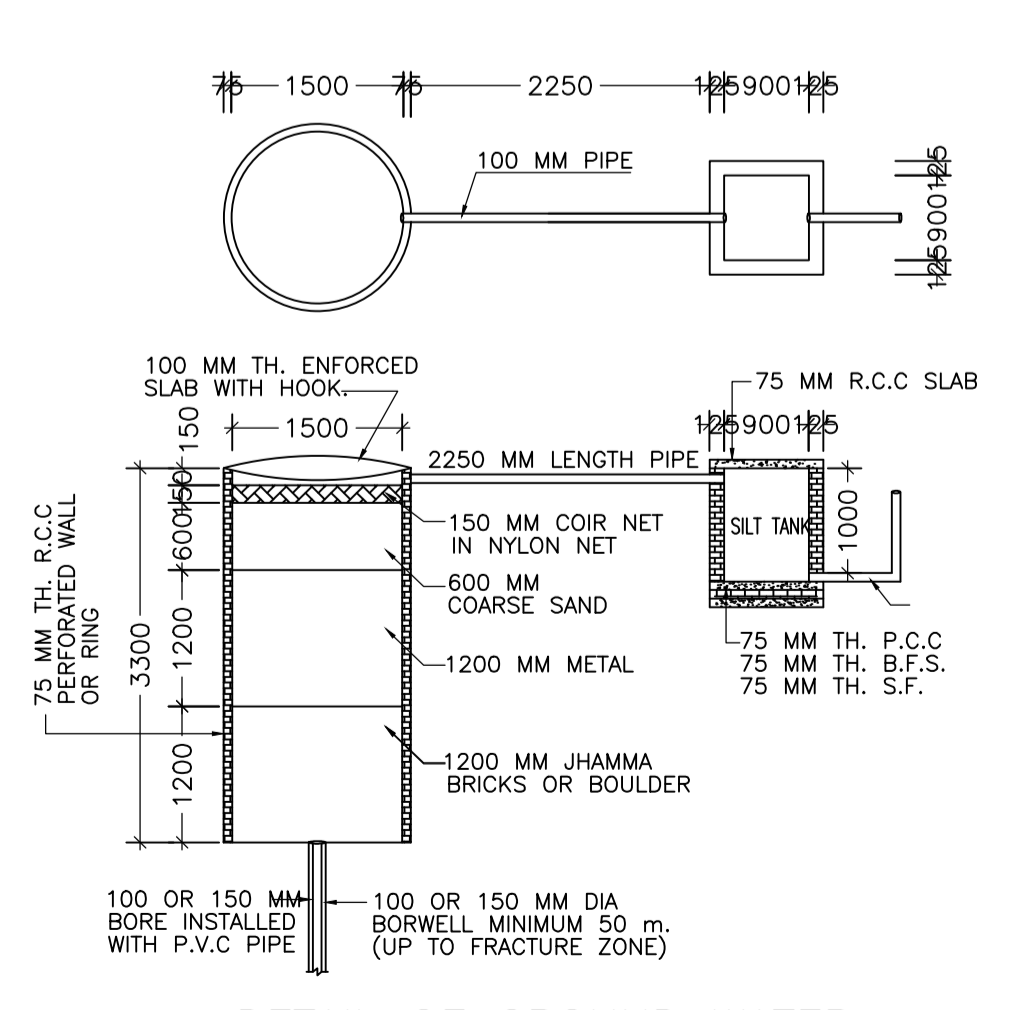
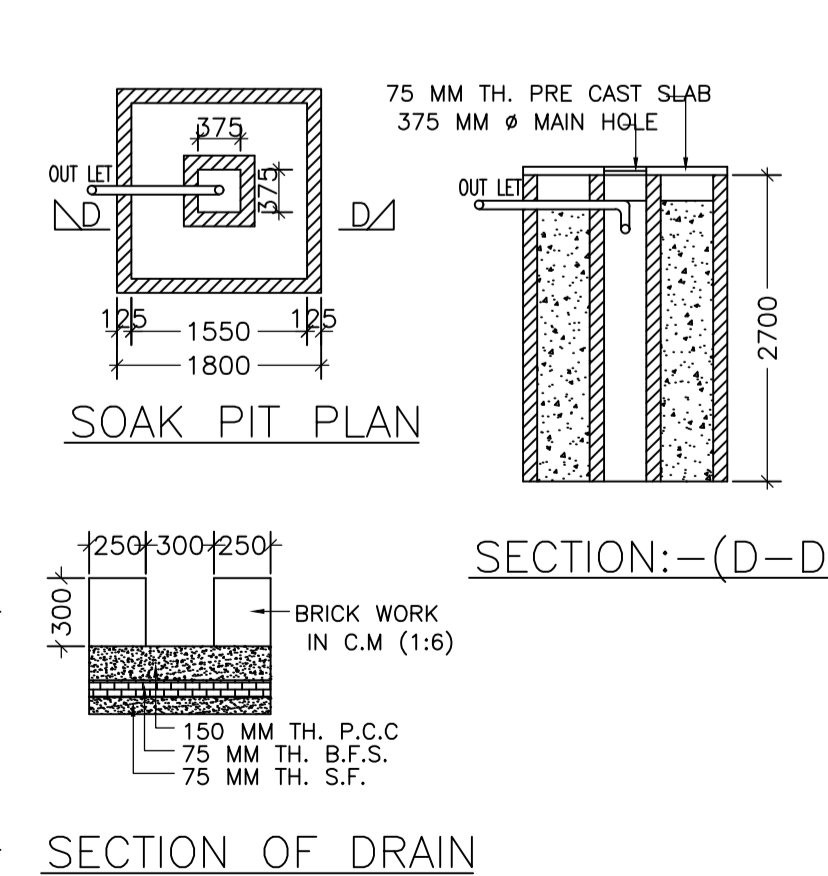
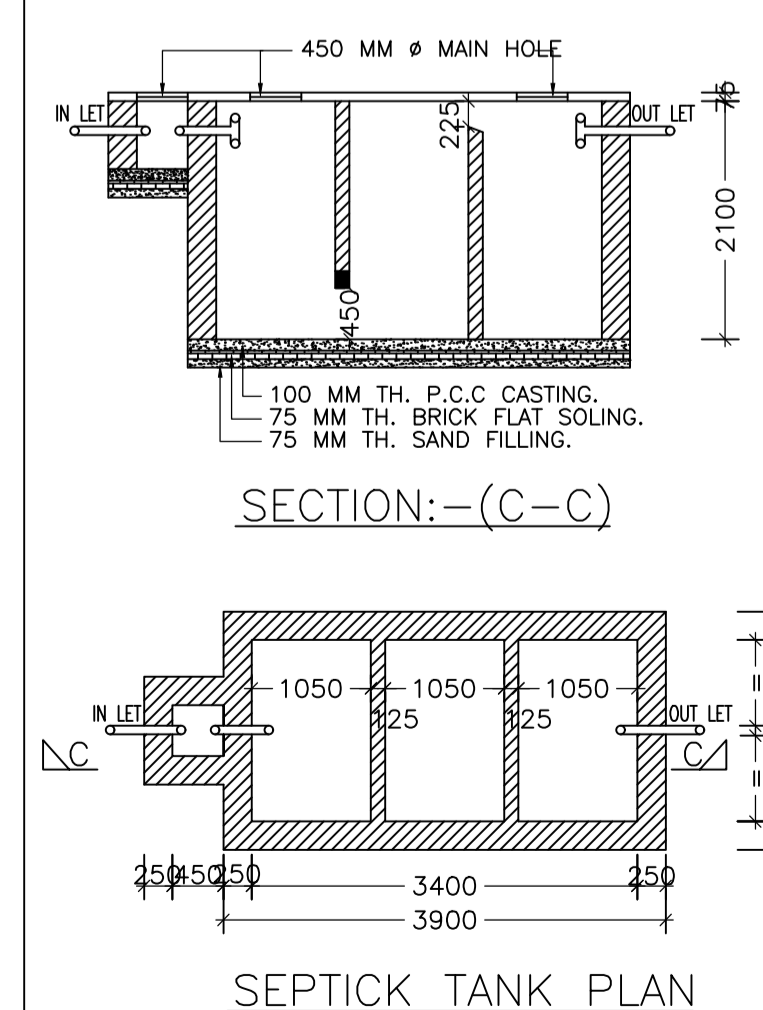

LTP NAME AND SIGNATURE ANITA KUMARI SNPC/ENG/0019/2020	STRUCTURAL ENG'S NAME AND SIGNATURE	BUILDER NAME AND SIGNATURE	DIGITAL SIGNATURE
--	-------------------------------------	----------------------------	-------------------