

Proposal Basic Information	
Proposal File No.	SNPC/ENG/0003/W04/2021
Owner Name	KABITA MANDAL
Khata No	35
Plot No	208
Village Name	Hansajudi
Use	Residential
SubUse	Bungalow/ Dwelling / Non Apartment

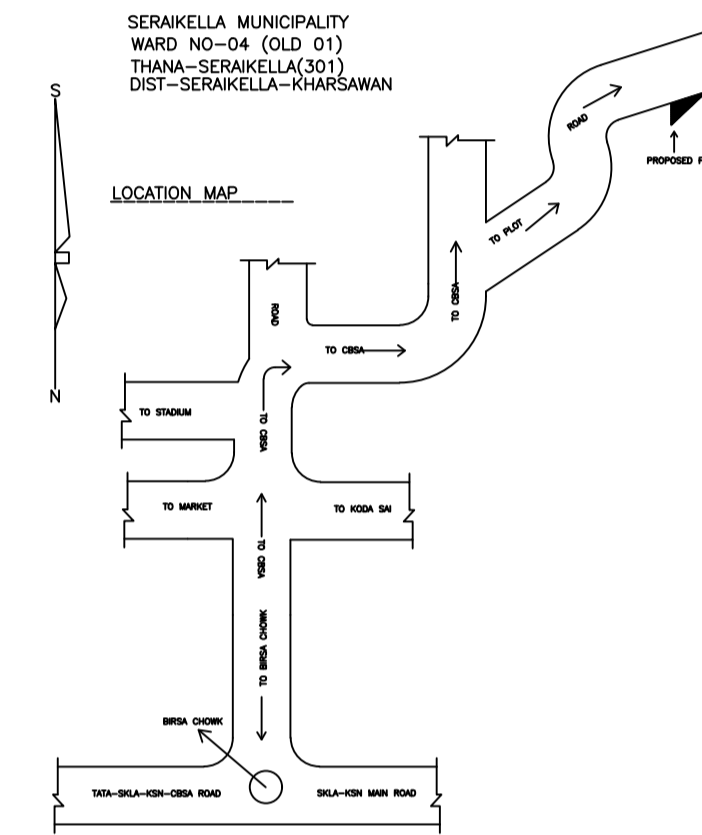

AREA STATEMENT	VERSION NO.: 1.0.58	SQ.MT.
SARAIKELA NAGAR PANCHAYAT	VERSION DATE: 16/10/2020	
PROJECT DETAIL:		
Region: JHARKHAND URBAN LOCAL BODIES	Plot Use: Residential	
District: SARAIKELA	Plot SubUse: Bungalow/ Dwelling / Non Apartment	
Authority: SARAIKELA NAGAR PANCHAYAT	Plot/Nearby/Religious Structure: NA	
Inward No: SNPC/BP/0003/W04/2021	Plot/SubPlot No: 208	
Application Type: General Proposal	North: Plot No. - 202	
Project Type: Building Permission	South: Road Width - 3.6	
Nature of Development: New	East: Plot No. - 208	
Location of Development Area: Old Area:	West: Road Width - 3.0	
AREA DETAILS:		
AREA OF PLOT (Minimum)	(A)	161.82
NET AREA OF PLOT(Gross Plot Area - Deduction from Gross Plot area)	(A-Deductions)	161.82
Deduction for Balance Plot Area(from Gross Plot Area)		
Common Plot		27.54
Total		27.54
BALANCE AREA OF PLOT(Net Plot Area - Recreational/Amenity space)	(A-Deductions)	134.27
PLOT AREA FOR COVERAGE(Net Plot Area)	(A-Deductions)	161.82
Plot Area for FAR (Net Plot Area + Road Widening Area)	(A-Deductions)	161.82
COVERAGE CHECK		
Permissible Coverage area ( 70.00 % )		113.27
Proposed Coverage Area ( 17.27 % )		27.94
Total Prop. Coverage Area ( 17.27 % )		27.94
Balance coverage area ( 52.73 % )		85.33
FAR CHECK		
Perm. FAR Area ( 1.80 )		291.28
Total Perm. FAR area		291.28
Residential FAR		27.94
Proposed FAR Area		27.94
Total Proposed FAR Area		27.94
Consumed FAR (Factor)		0.17
Balance FAR Area		263.34
BUILT UP AREA CHECK		
Total Proposed BuiltUp Area		27.94
ARCHITECT (Regd)	ANITA KUMARI	
ENGINEER (Regd)		
SUPERVISOR (Regd)		
OWNER (Regd)	KABITA MANDAL	
DEVELOPMENT AUTHORITY		LOCAL BODY

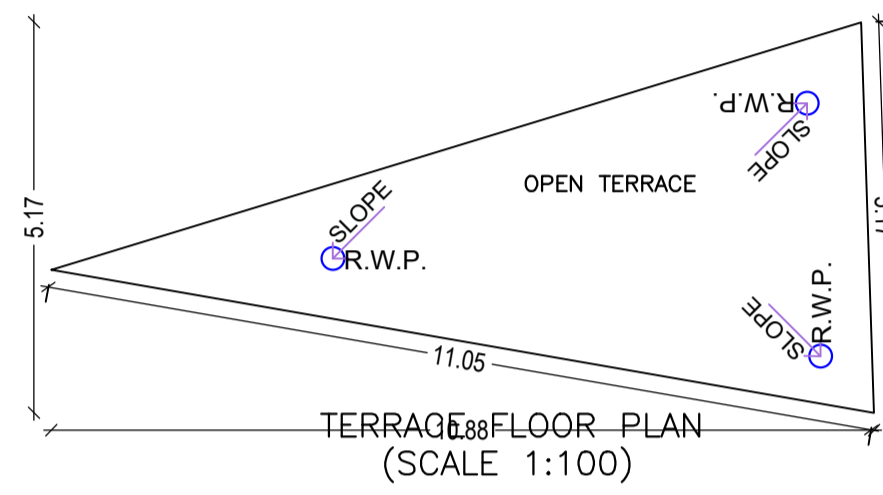
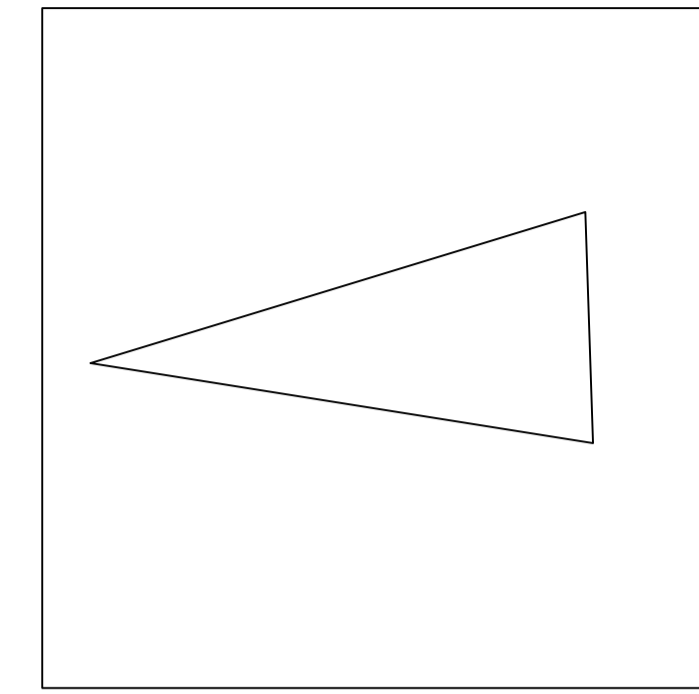
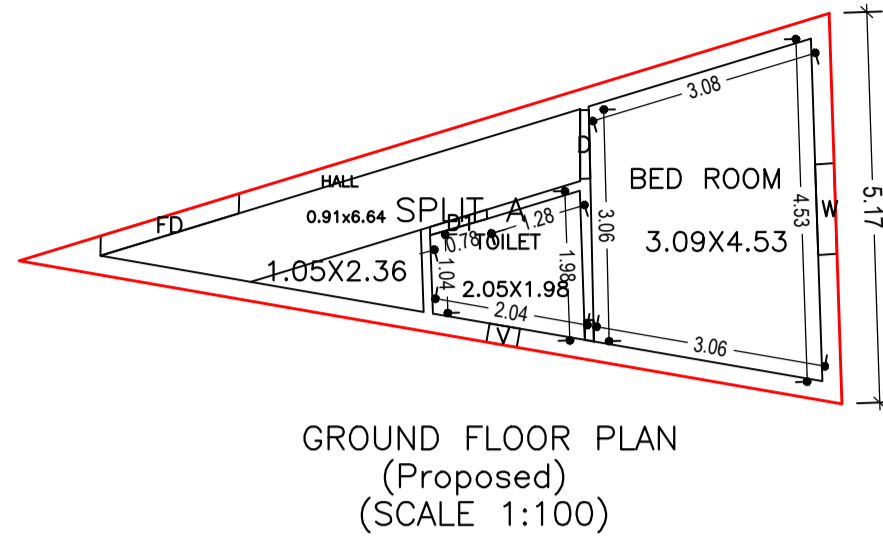
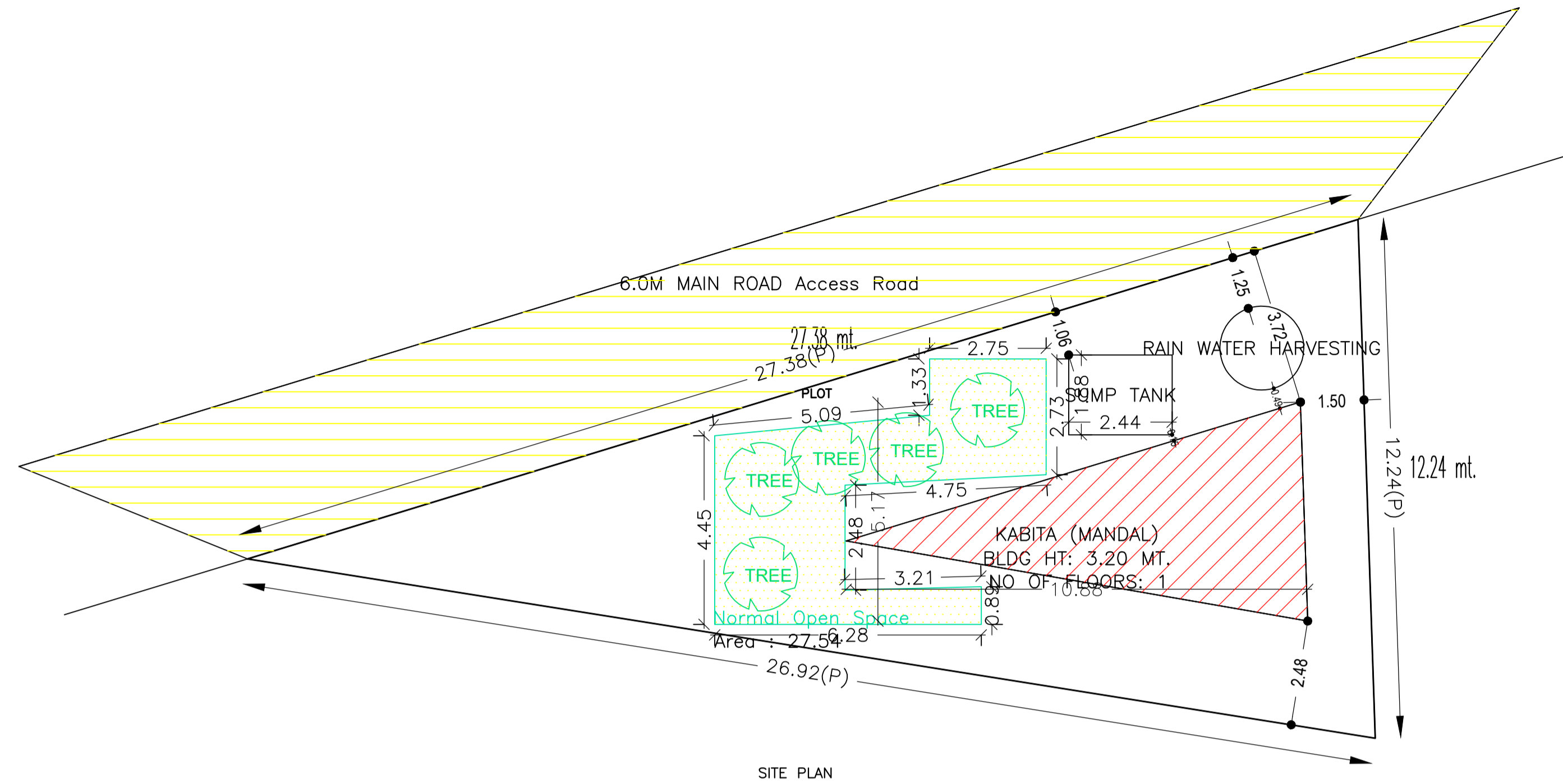
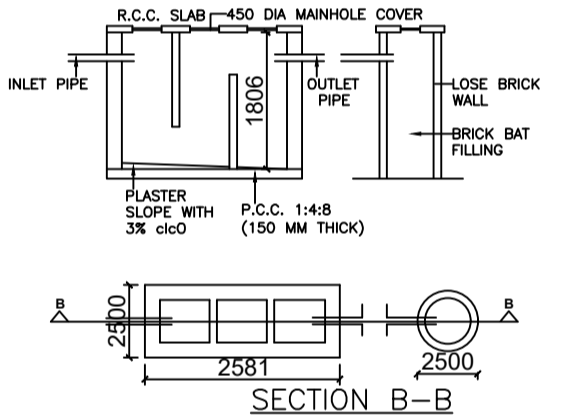
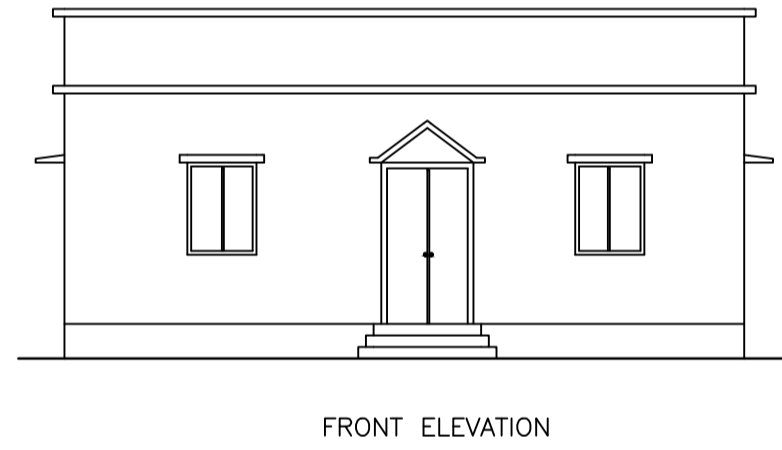
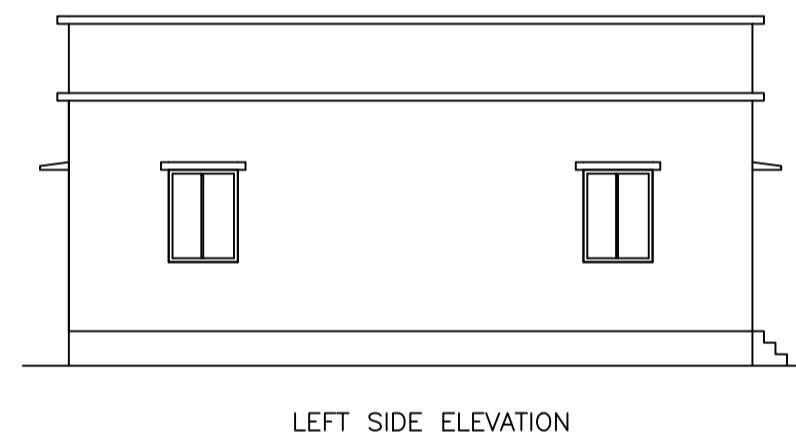

DETAIL OF SEPTIC TANK & SOAKPIT  
Septic Tank Detail

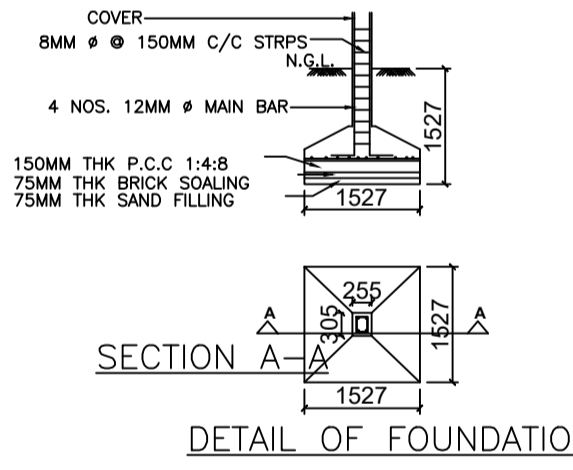

DETAIL OF FOUNDATION  
Structure Detail

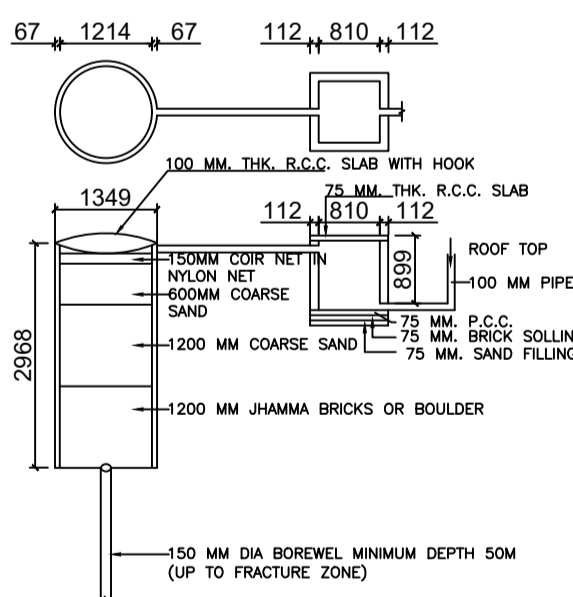

Rain Water Storage Tank Detail  
DETAIL OF GROUND WATER RECHARGE PIT WITH SILT TANK

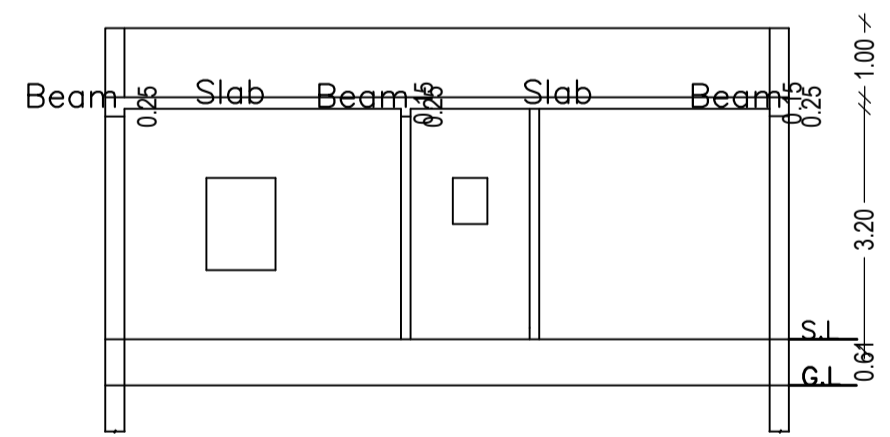

Building Use/SUBUSE Details

Building Name	Building Use	Building SubUse	Building Structure
KABITA (MANDAL)	Residential	Bungalow/ Dwelling / Non Apartment	Non-Highrise

Buildingwise Floor FAR Details

Floor Name	Building Name KABITA (MANDAL)		Total	
	Proposed Built Up Area (Sq.mt.)	Proposed FAR Area (Sq.mt.)	Total Proposed Built Up Area (Sq.mt.)	Total FAR Area (Sq.mt.)
Ground Floor	27.94	27.94	27.94	27.94
Terrace Floor	0.00	0.00	0.00	0.00
Total:	27.94	27.94	27.94	27.94

COLOR INDEX

PLOT BOUNDARY	Black
ABUTTING ROAD	Red
PROPOSED CONSTRUCTION	Green
COMMON PLOT	Yellow
ROAD WIDENING AREA	Blue
EXISTING (To be retained)	Orange
EXISTING (To be demolished)	Purple

LTP NAME AND SIGNATURE	STRUCTURAL ENG'S NAME AND SIGNATURE	BUILDER NAME AND SIGNATURE	DIGITAL SIGNATURE
ANITA KUMARI SNPC/ENG/0019/2020			

Building :KABITA (MANDAL)

Floor Name	Total Built Up Area (Sq.mt.)	Proposed FAR Area (Sq.mt.) Resi.	Total FAR Area (Sq.mt.)	Total Consumed Additional FAR Area (Sq.mt.)	Trnmt (No.)
Ground Floor	27.94	27.94	27.94	27.94	01
Terrace Floor	0.00	0.00	0.00	0.00	00
Total:	27.94	27.94	27.94	27.94	01
Total Number of Same Buildings	1				
Total:	27.94	27.94	27.94	27.94	01

SCHEDULE OF DOOR:

BUILDING NAME	NAME	LENGTH	HEIGHT	NOS
KABITA (MANDAL)	D1	0.79	2.10	01
KABITA (MANDAL)	D	0.91	2.10	01
KABITA (MANDAL)	FD	1.91	2.10	01

SCHEDULE OF WINDOW/VENTILATION:

BUILDING NAME	NAME	LENGTH	HEIGHT	NOS
KABITA (MANDAL)	V	0.41	1.20	01
KABITA (MANDAL)	W	1.20	1.20	01

FAR & Tenement Details (Table 4c-1)

Building	No. of Same Bldg	Total Built Up Area (Sq.mt.)	Proposed FAR Area (Sq.mt.) Resi.	Total FAR Area (Sq.mt.)	Total Consumed Additional FAR Area (Sq.mt.)	Trnmt (No.)
KABITA (MANDAL)	1	27.94	27.94	27.94	27.94	01
Grand Total:	1	27.94	27.94	27.94	27.94	01

UnitBUA Table for Building :KABITA (MANDAL)

FLOOR	Name	UnitBUA Type	UnitBUA Area	Carpet Area	No. of Rooms	No. of Tenement
GROUND FLOOR PLAN	SPLIT A	FLAT	21.51	21.48	3	1
Total:	-	-	21.51	21.48	3	1