

# Project Title :MR .SUSHIL KUMAR SAHU

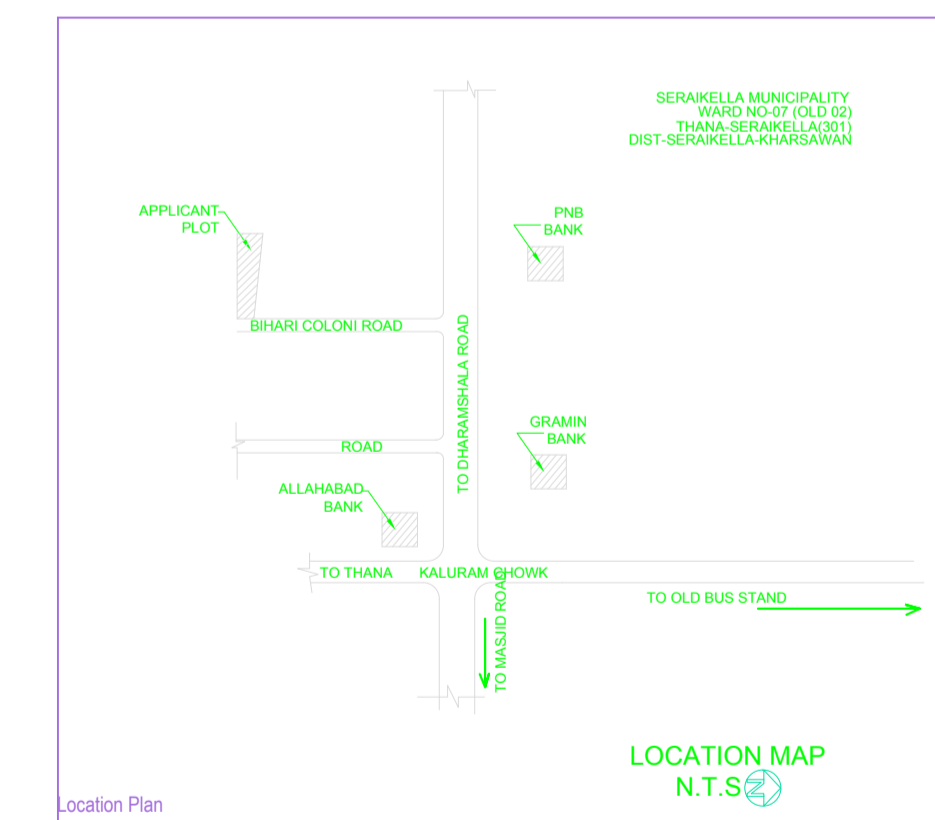
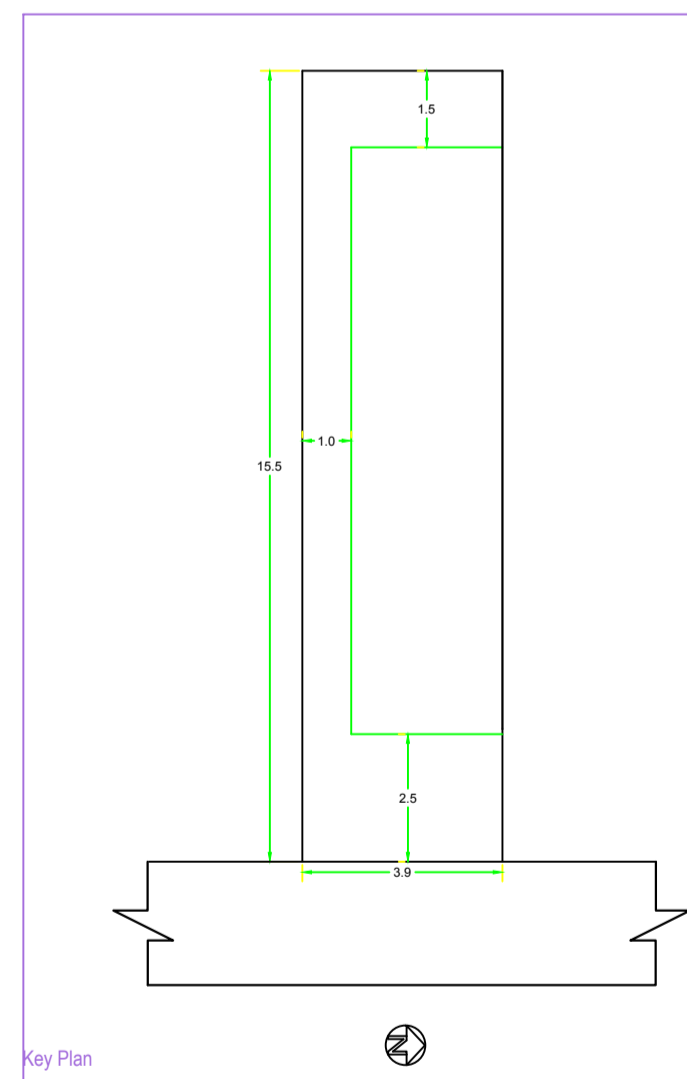
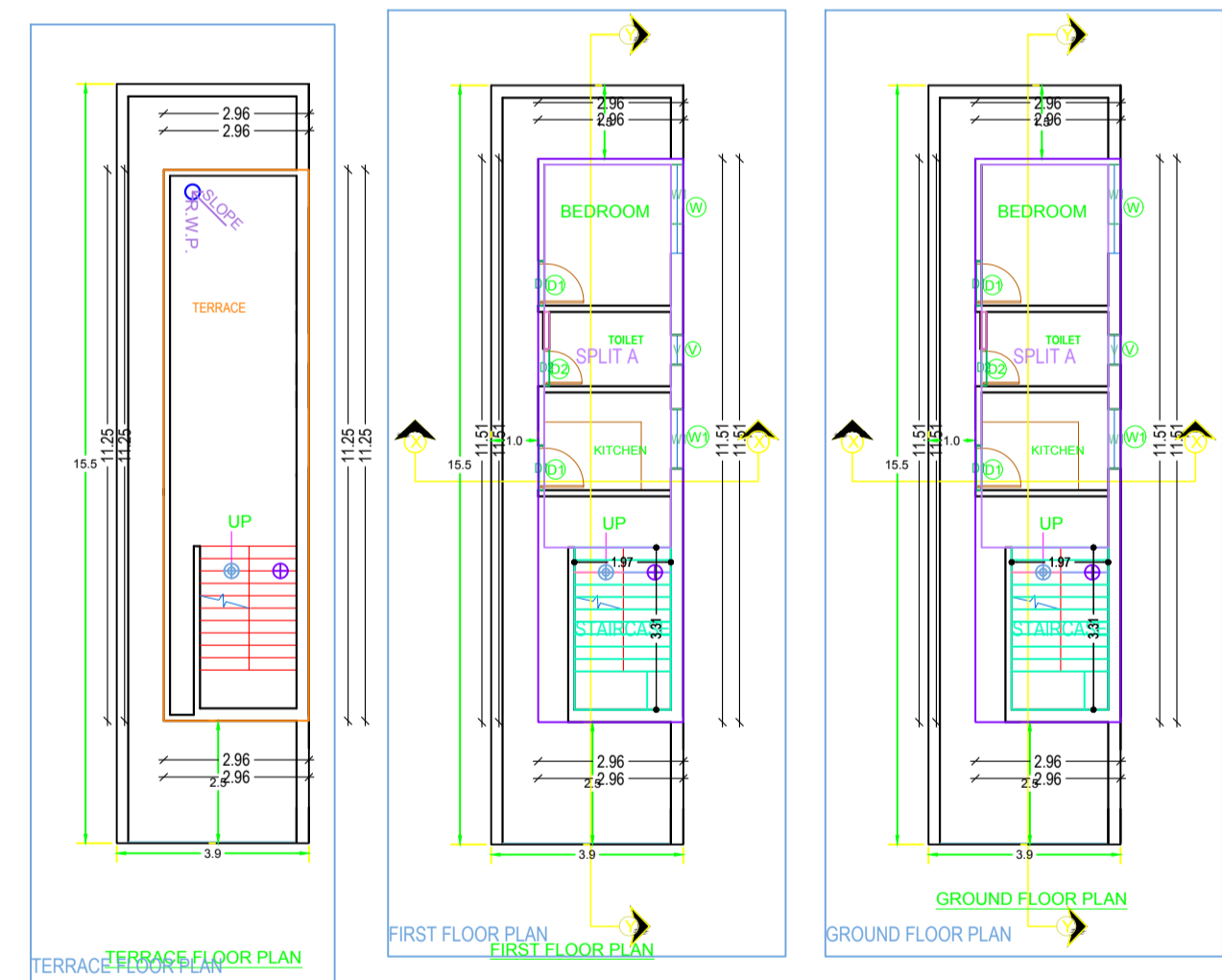
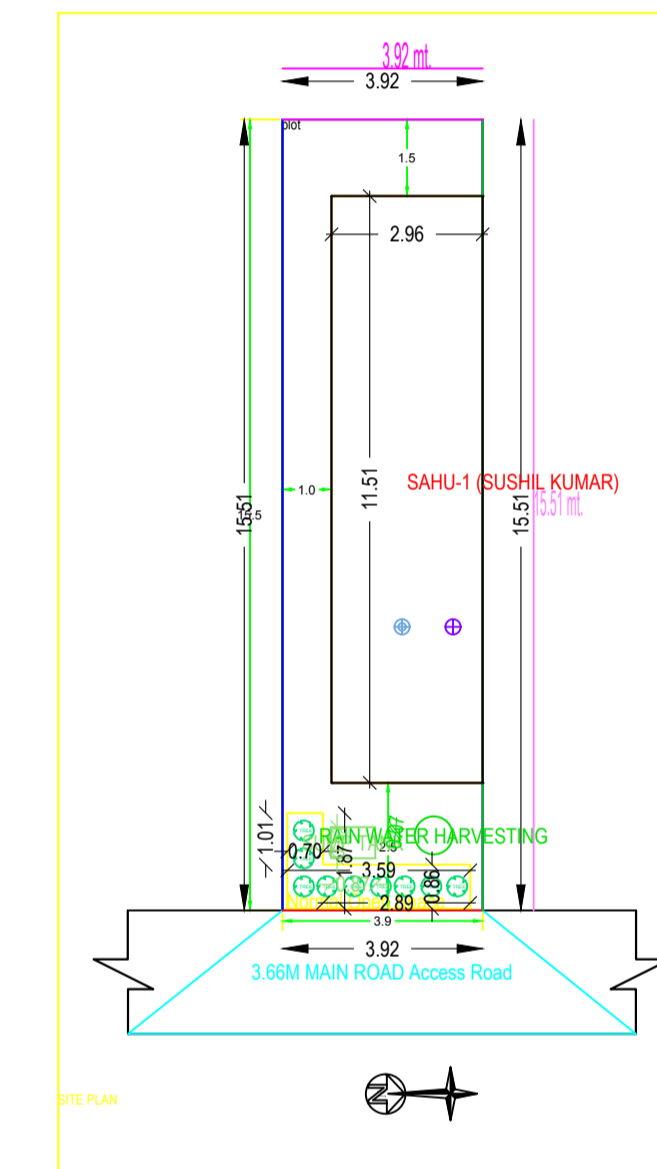
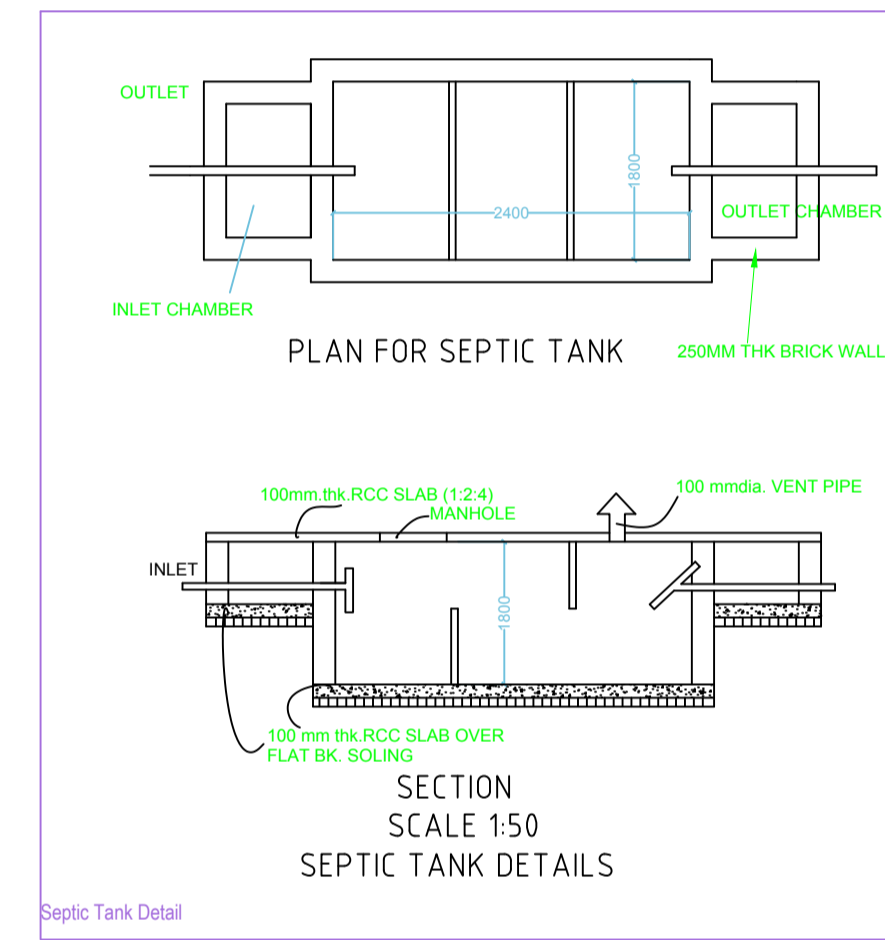
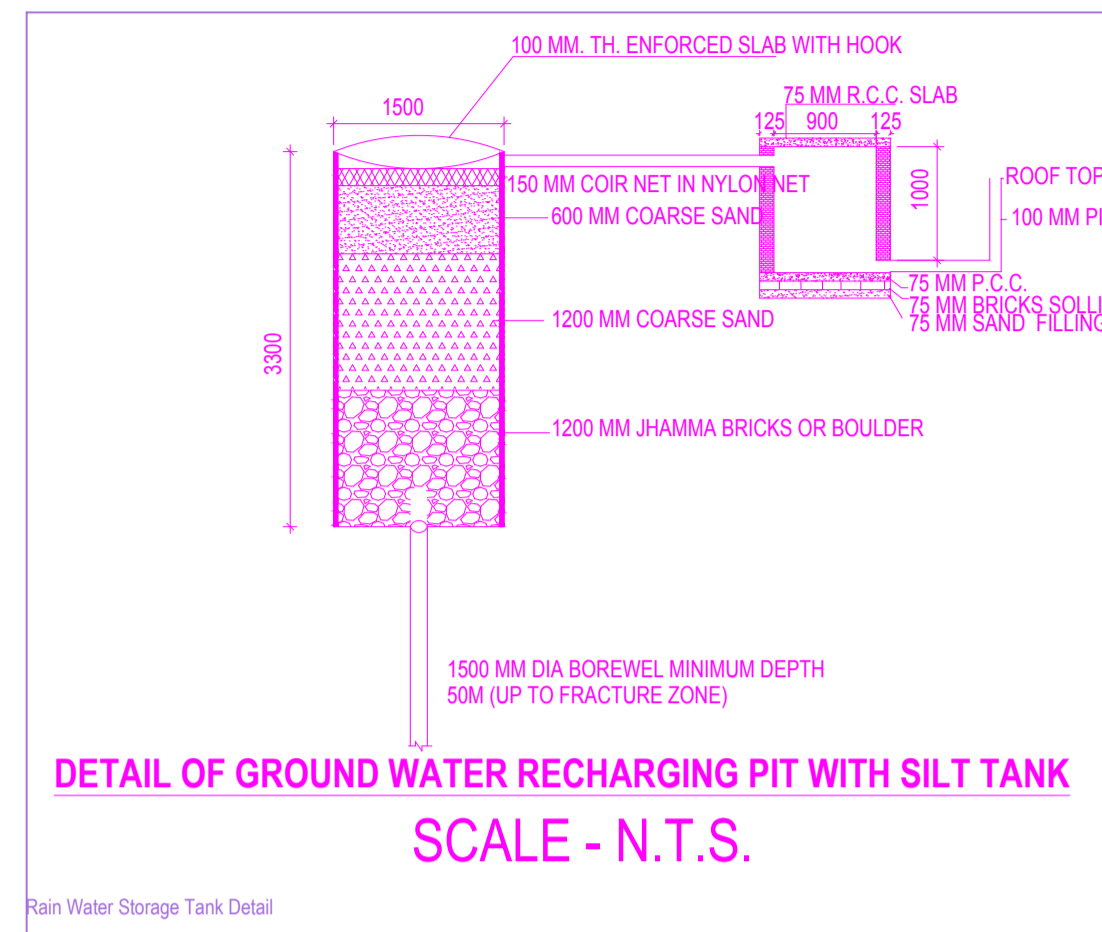
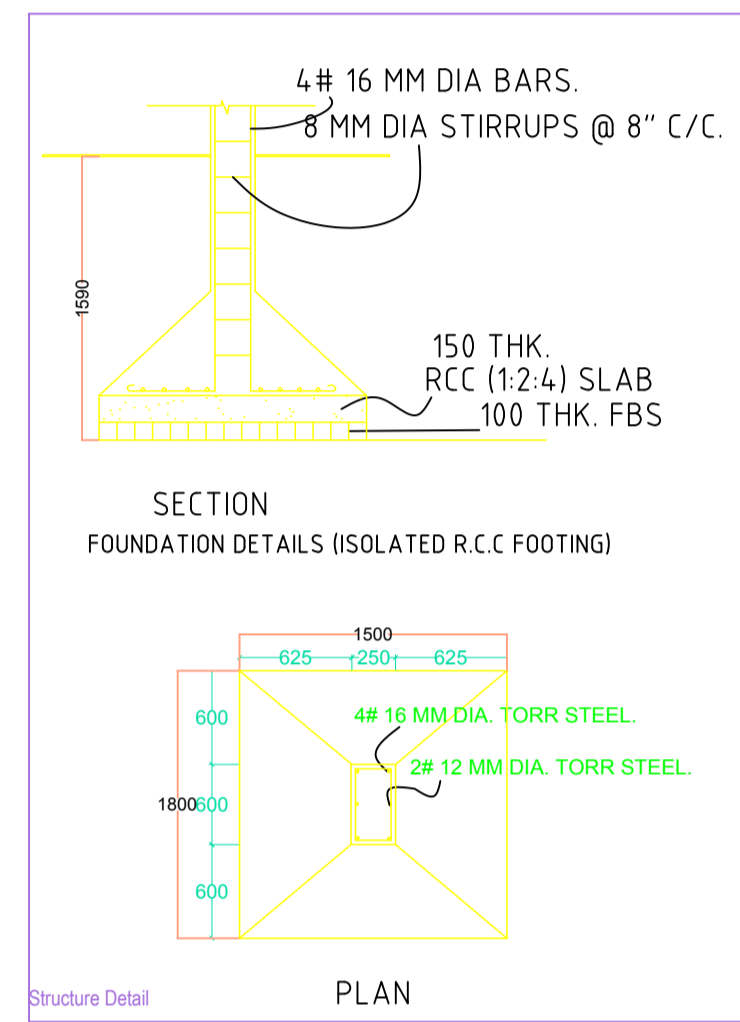
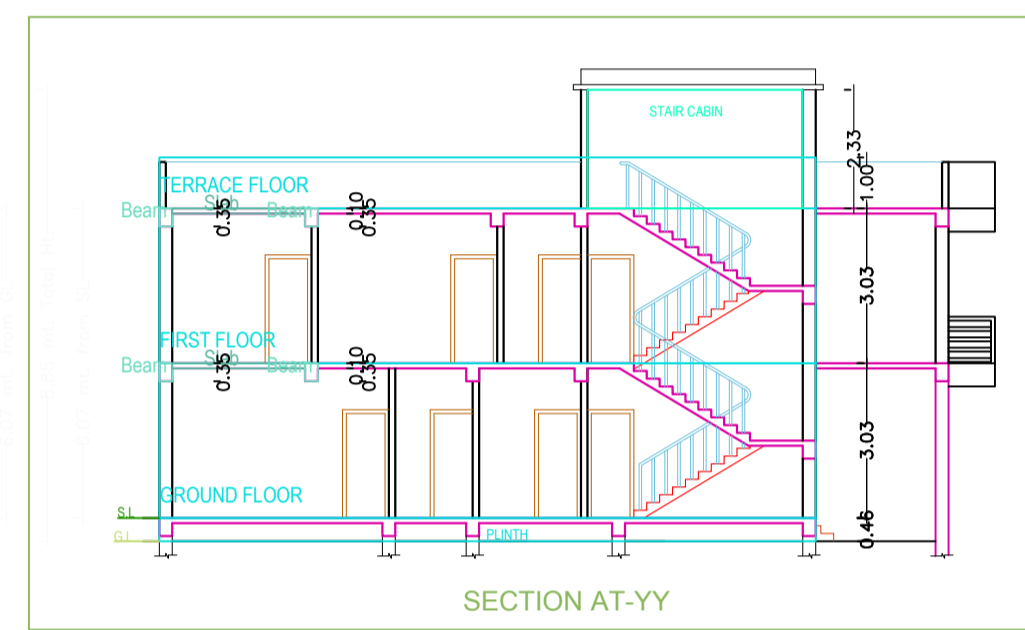
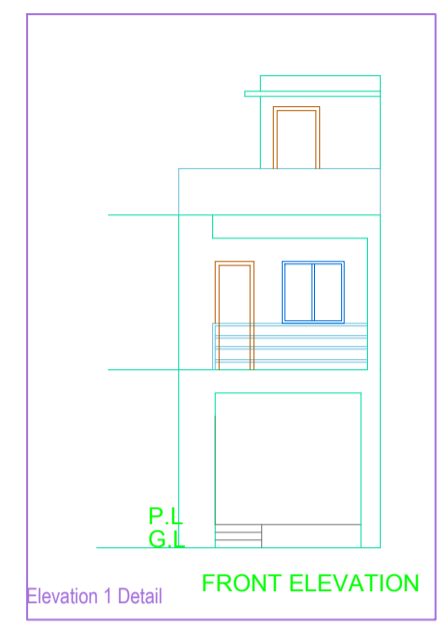
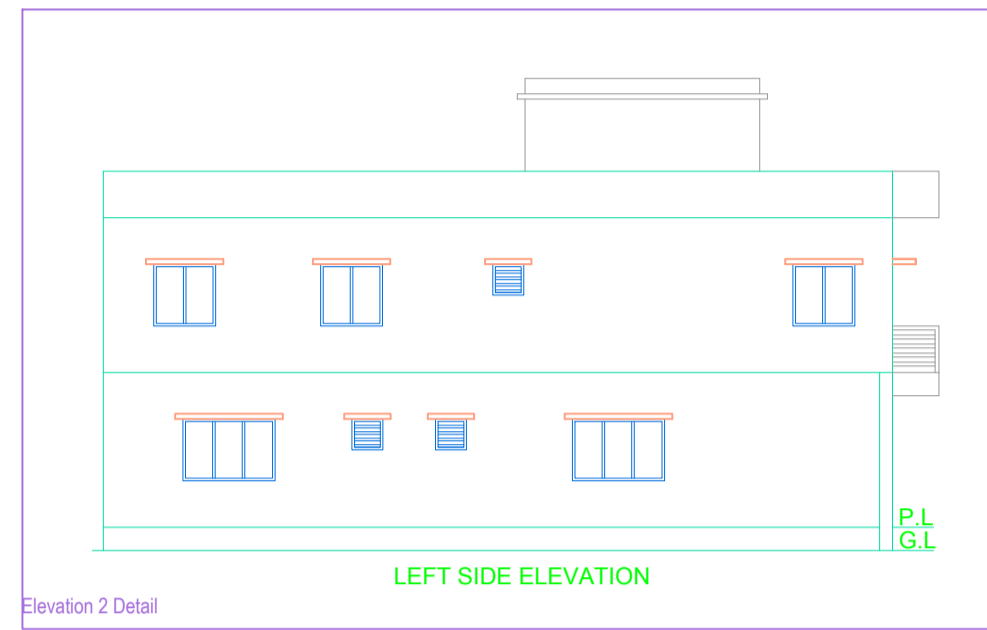

**PROJECT**  
PROPOSED RESIDENCE BUILDING FOR MR.SUSHIL SAHU

**CLIENT**  
PROPOSED BUILDING FOR MR. SUSHIL KUMAR SAHU AT WARD NO.2, PLOT NO.-246, KHATA NO.-158, P.S. NO.-301, THANA-SERAIKELLA, DISTT.-SERAIKELLA-KHARSAWAN JHARKHAND.

DESIGNED & CHECKED BY: ANITA KUMARI sheet 01

ISSUE ONLY FOR Submission

AREA STATEMENT SERAIKELLA NAGAR PANCHAYAT	VERSION NO. 1.0.27
PROJECT DETAIL:	VERSION DATE: 16/10/2020
Invest No.:	Plot Use: Residential
Region: JHARKHAND URBAN LOCAL BODIES	Plot SubUse: Bungalow/ Dwelling / Non Apartment
District: SERAIKELLA	Land Use Zone: Residential
Application Type: General Proposal	Plotting Road Width:
Project Type: Building Permission	Plot No.:
Nature of Development: New	Revenue Survey No/Survey No.:
Location: Old Area	Thana No.:
Site Location: NA	Holding No.:
Village/Mauza Name: -	Khata No.:
Ward No.:	North:
Road/Street:	South:
	East:
	West:

AREA DETAILS:		SQ.MT.
AREA OF PLOT (Minimum)	(A)	60.86
Net Plot Area (Gross Plot Area - Deductions from Gross Plot Area)	(A-Deductions)	60.86
Deductions for Balance Plot Area (from Gross Plot Area)		
COP Area		3.81
Total		3.81
Balance Plot Area (Net Plot Area - Recreation/energy space)	(A-Deductions)	57.05
Plot Area for Coverage (Net Plot Area)	(A-Deductions)	60.86
Plot Area for FSI (Net Plot Area + Road/Watering Area)	(A-Deductions)	60.86
FOOTPATH CHECK		
Proposed Coverage Area (56.05%)		34.11
Total Coverage Area (56.05%)		34.11
FAR CHECK		
Proposed Area of FAR		68.22
Total Area of FAR		68.22
BUILT UP AREA CHECK		
Total Proposed Builtup Area		68.22
ARCH/ENGG/SUPERVISOR (Regd)		OWNER
DEVELOPMENT AUTHORITY		LOCAL BODY

COLOR INDEX	
PILOT BOUNDARY	█
ABUTTING ROAD	█
PROPOSED WORK (COVERAGE AREA)	█
EXISTING (To be retained)	█
EXISTING (To be demolished)	█

MARGIN DETAIL:					
Building / Wing Name	Road Name	Front Margin	Rear Margin	Side1 Margin	Side2 Margin
SUSHIL (SUSHIL)	3.66M MAIN ROAD Access Road	2.50	1.50	0.96	0.00

FAR & Tenement Details (Table 4c-1)					
Building	No. of Same Bldg	Total Built Up Area (Sq.mt.)	Proposed FAR Area (Sq.mt.)	Total FAR Area (Sq.mt.)	Tenmt (No.)
SUSHIL (SUSHIL)	1	68.22	68.22	68.22	01
Gross Total:	1	68.22	68.22	68.22	01

Building :SUSHIL (SUSHIL)					
Floor Name	Total Built Up Area (Sq.mt.)	Proposed FAR Area (Sq.mt.)	Total FAR Area (Sq.mt.)	Tenmt (No.)	
Ground Floor	34.11	34.11	34.11	01	
First Floor	34.11	34.11	34.11	00	
Terrace Floor	0.00	0.00	0.00	00	
Total	68.22	68.22	68.22	01	
Total Number of Same Buildings	1				
Total	68.22	68.22	68.22	01	

SCHEDULE OF JOINERY:					
BUILDING NAME	NAME	LENGTH	HEIGHT	MOS	
SUSHIL (SUSHIL)	D2	0.75	2.10	02	
SUSHIL (SUSHIL)	D1	0.91	2.10	04	
Total	-	-	-	06	

SCHEDULE OF JOINERY:					
BUILDING NAME	NAME	LENGTH	HEIGHT	MOS	
SUSHIL (SUSHIL)	V	0.91	1.00	02	
SUSHIL (SUSHIL)	V1	1.21	1.20	04	
Total	-	-	-	06	

UnitBUA Table for Building :SUSHIL (SUSHIL)						
FLOOR	Name	SHRUA Type	UnitBUA Area	Carpet Area	No. of Rooms	No. of Tenement
GROUND FLOOR/PLAN	SPLIT A	FLAT	40.44	40.29	3	1
Total	-	-	40.44	40.29	6	1