

ISO\_A1\_(841.00\_x\_594.00\_MM)

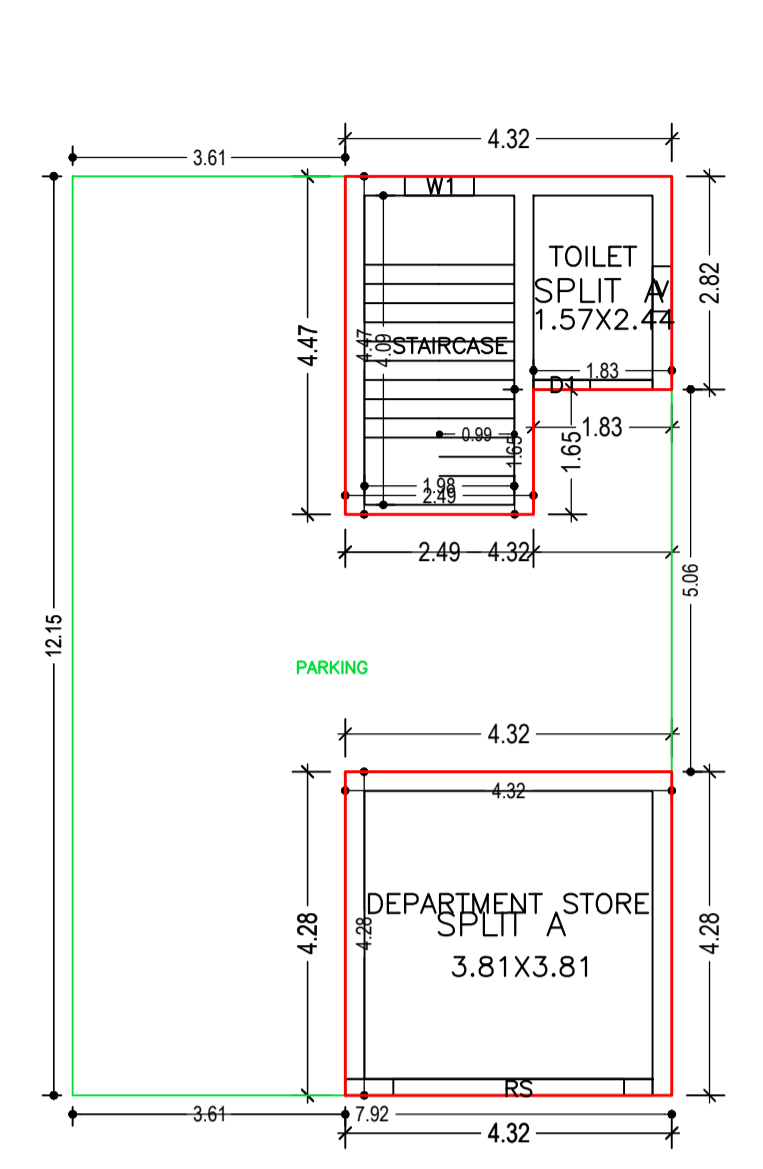

GROUND FLOOR PLAN (Proposed) (SCALE 1:100)

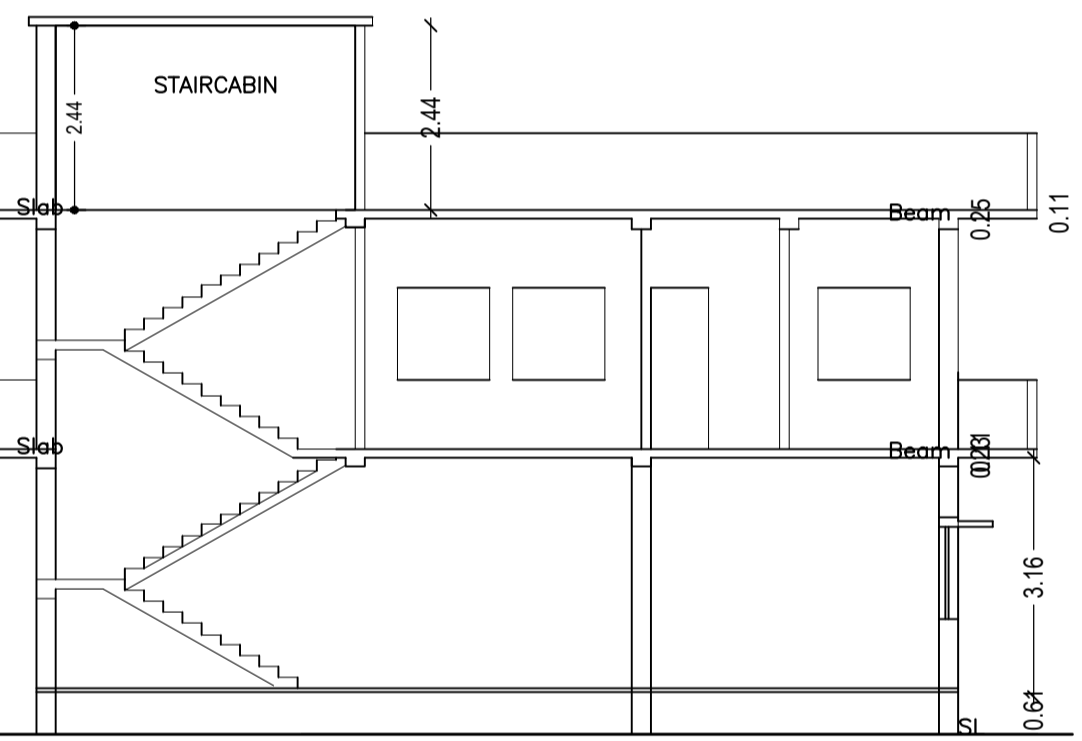

SECTION Y-Y

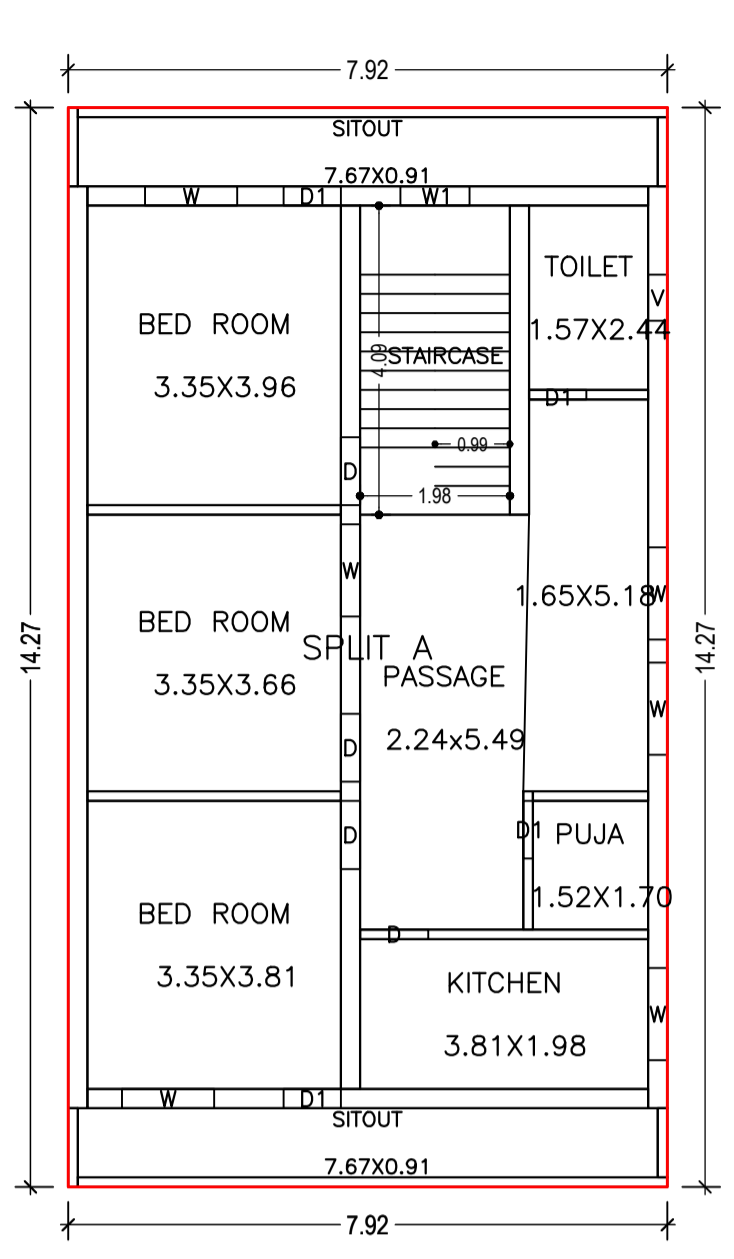

FIRST FLOOR PLAN (Proposed) (SCALE 1:100)

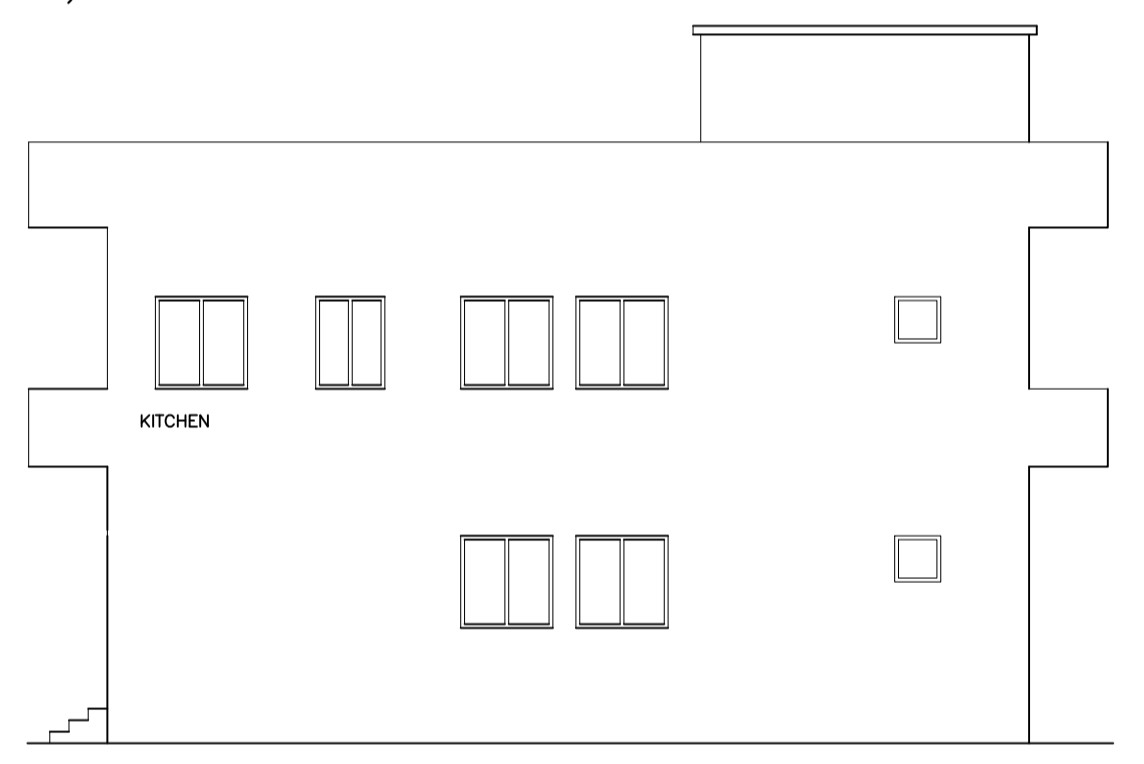

SIDE ELEVATION

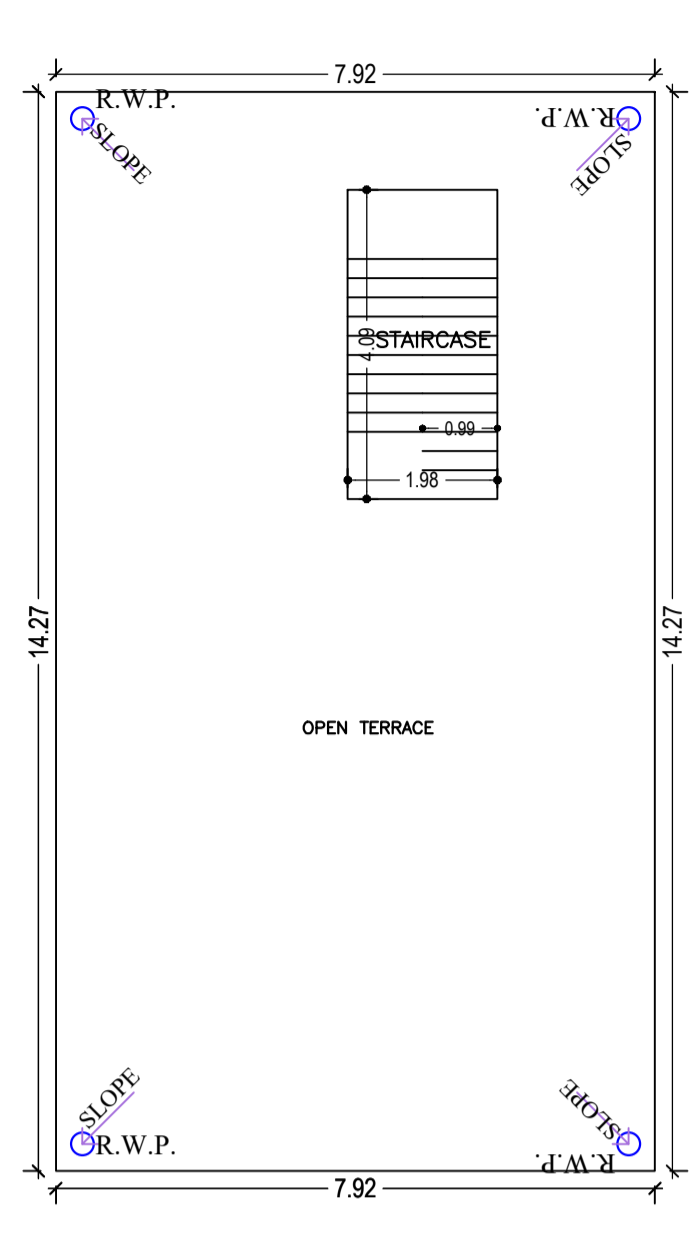

TERRACE FLOOR PLAN (SCALE 1:100)

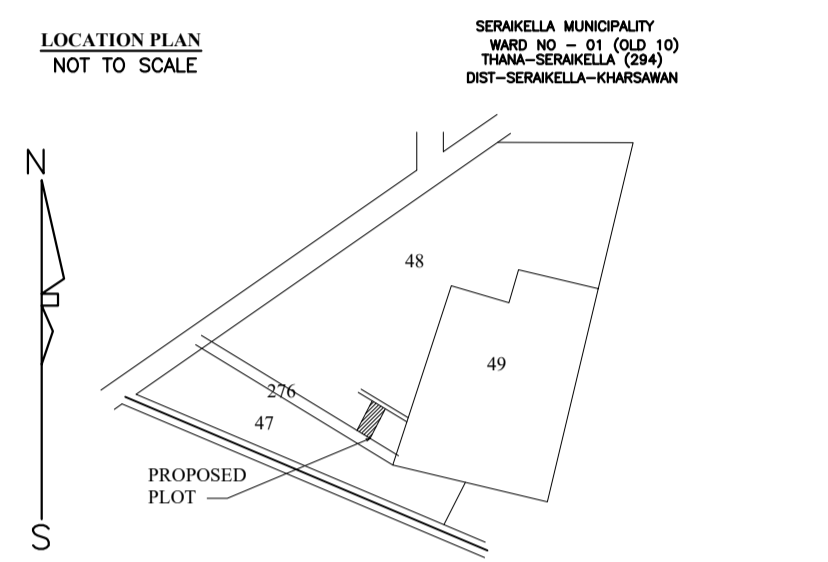
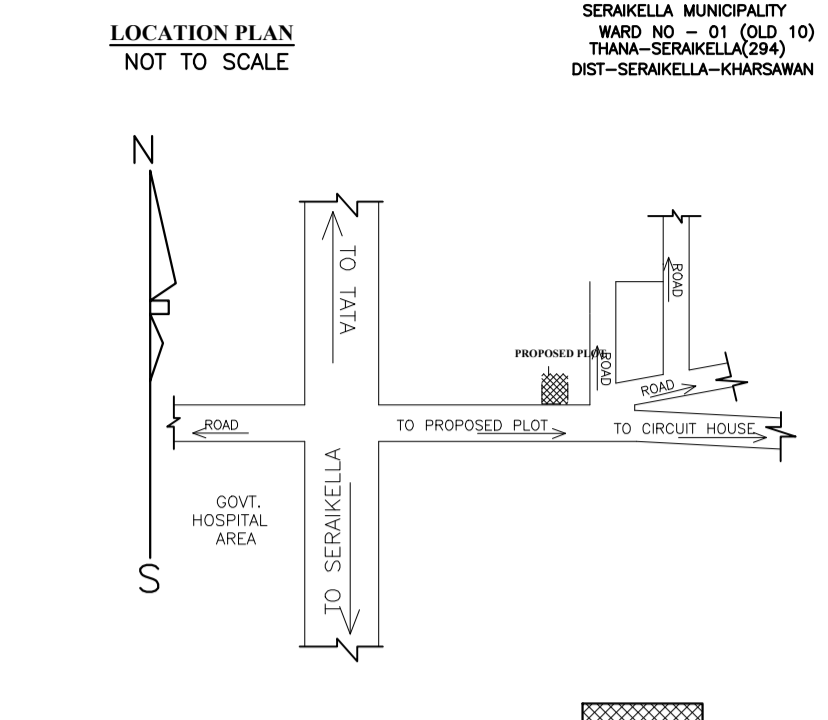

**COLOR INDEX**

PLOT BOUNDARY	Black
ABUTTING ROAD	Red
PROPOSED CONSTRUCTION	Green
COMMON PLOT	Yellow
ROAD WIDENING AREA	Blue
EXISTING (To be retained)	Light Blue
EXISTING (To be demolished)	Dark Blue

**Buildingwise Floor FAR Details**

Floor Name	Building Name A (A1)		Total	
	Proposed Built Up Area (Sq.mt.)	Proposed FAR Area (Sq.mt.)	Total Proposed Built Up Area (Sq.mt.)	Total FAR Area (Sq.mt.)
Ground Floor	96.32	34.76	96.32	34.76
First Floor	113.12	113.12	113.12	113.12
Terrace Floor	0.00	0.00	0.00	0.00
<b>Total :</b>	<b>209.44</b>	<b>147.88</b>	<b>209.44</b>	<b>147.88</b>

**Building USE/SUBUSE Details**

Building Name	Building Use	Building SubUse	Building Structure
A (A1)	Residential	Bungalow/ Dwelling / Non Apartment	Non-Highrise

**FAR & Tenement Details (Table 4c-1)**

Building	No. of Same Bldg	Total Built Up Area (Sq.mt.)	Deductions (Area in Sq.mt.)		Proposed FAR Area (Sq.mt.)	Total FAR Area (Sq.mt.)	Total Consumed Additional FAR Area (Sq.mt.)	Tnmt (No.)
			Parking	Resi.				
A (A1)	1	209.44	61.56	147.88	147.88	147.88	01	
<b>Grand Total :</b>	<b>1</b>	<b>209.44</b>	<b>61.56</b>	<b>147.88</b>	<b>147.88</b>	<b>147.88</b>	<b>01</b>	

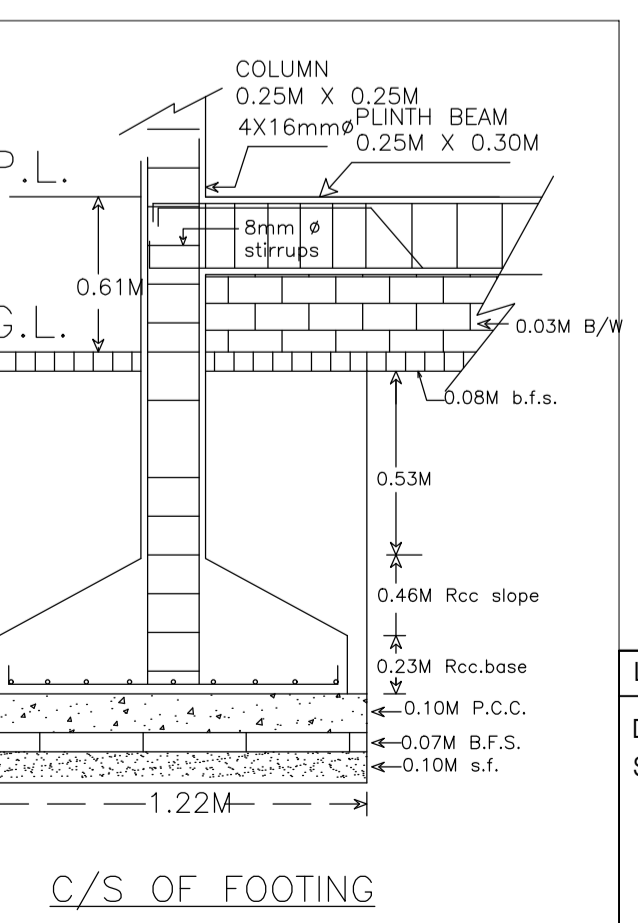

C/S OF FOOTING

**Proposal Basic Information**

Proposal File No.	SNPC/BP/0004/W01/2021
Owner Name	BIMALA KUMARI
Khata No	19
Plot No	48/A
Village Name	Sundarpur
Use	Residential
SubUse	Other Residential Building

**AREA STATEMENT**

AREA STATEMENT	VERSION NO. : 1.0.53	SQ.MT.
AREA OF PLOT (Minimum)	(A)	141.76
NET AREA OF PLOT(Gross Plot Area - Deduction from Gross Plot area)	(A-Deductions)	141.76
Deduction for Balance Plot Area(from Gross Plot Area)		
Common Plot		12.15
Total		12.15
BALANCE AREA OF PLOT(Net Plot Area - Recreational/Amenity space)	(A-Deductions)	129.61
PLOT AREA FOR COVERAGE(Net Plot Area)	(A-Deductions)	141.76
Plot Area for FAR (Net Plot Area + Road Widening Area)	(A-Deductions)	141.76
COVERAGE CHECK		
Permissible Coverage area ( 70.00 % )		99.23
Proposed Coverage Area ( 67.95 % )		96.32
Total Prop. Coverage Area ( 67.95 % )		96.32
Balance coverage area ( 2.05 % )		2.91
FAR CHECK		
Perm. FAR Area ( 1.80 )		255.17
Total Perm. FAR area		255.17
Residential FAR		147.89
Proposed FAR Area		147.89
Total Proposed FAR Area		147.89
Consumed FAR (Factor)		1.04
Balance FAR Area		107.28
BUILT UP AREA CHECK		
Total Proposed BuiltUp Area		209.44
ARCHITECT (Regd)	DURGA PRASAD DUBEY	
ENGINEER (Regd)		
SUPERVISOR (Regd)		
OWNER (Regd)	BIMALA KUMARI	
DEVELOPMENT AUTHORITY		LOCAL BODY

**SCHEDULE OF DOOR:**

BUILDING NAME	NAME	LENGTH	HEIGHT	NOS
A (A1)	D1	0.75	2.10	01
A (A1)	D1	0.76	2.10	04
A (A1)	D	0.90	2.10	04
A (A1)	RS	3.05	2.10	01

**SCHEDULE OF WINDOW/VENTILATION:**

BUILDING NAME	NAME	LENGTH	HEIGHT	NOS
A (A1)	V	0.60	0.60	01
A (A1)	V	0.61	0.61	01
A (A1)	W1	0.91	1.20	02
A (A1)	W	1.22	1.20	06

**Building :A (A1)**

Floor Name	Total Built Up Area (Sq.mt.)	Deductions (Area in Sq.mt.)		Proposed FAR Area (Sq.mt.)	Total FAR Area (Sq.mt.)	Total Consumed Additional FAR Area (Sq.mt.)	Tnmt (No.)
		Parking	Resi.				
Ground Floor	96.32	61.56	34.76	34.76	34.76	01	
First Floor	113.12	0.00	113.12	113.12	113.12	00	
Terrace Floor	0.00	0.00	0.00	0.00	0.00	00	
<b>Total :</b>	<b>209.44</b>	<b>61.56</b>	<b>147.88</b>	<b>147.88</b>	<b>147.88</b>	<b>01</b>	
Total Number of Same Buildings	1						
<b>Total :</b>	<b>209.44</b>	<b>61.56</b>	<b>147.88</b>	<b>147.88</b>	<b>147.88</b>	<b>01</b>	

**UnitBUA Table for Building :A (A1)**

FLOOR	Name	UnitBUA Type	UnitBUA Area	Carpet Area	No. of Rooms	No. of Tenement
GROUND FLOOR PLAN	SPLIT A	FLAT	116.88	111.96	1	1
FIRST FLOOR PLAN	SPLIT A	FLAT	0.00	0.00	9	0
<b>Total:</b>			<b>116.88</b>	<b>111.96</b>	<b>11</b>	<b>1</b>

LTP NAME AND SIGNATURE	STRUCTURAL ENG'S NAME AND SIGNATURE	BUILDER NAME AND SIGNATURE	DIGITAL SIGNATURE
DURGA PRASAD DUBEY SNPC/ENG/0004/2017			

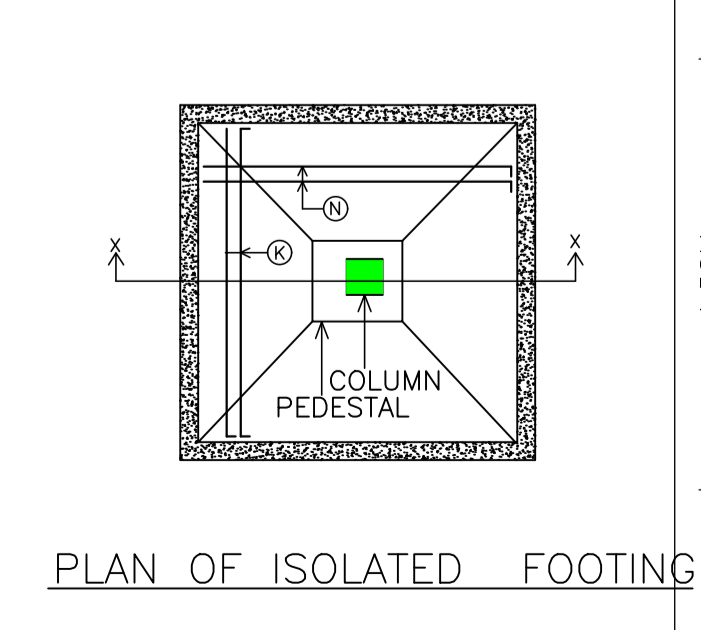

PLAN OF ISOLATED FOOTING