

Proposal Basic Information

Proposal File No.	SNPC/BP/0006/W01/2023
Owner Name	DIPALI JYOTISHI
Khata No	2
Plot No	249
Village Name	Gutusiai
Use	Residential
SubUse	Bungalow/ Dwelling / Non Apartment

Building :A (RESIDENTIAL)

Floor Name	Total Built Up Area (Sq.mt.)	Proposed FAR Area (Sq.mt.) Resi.	Total FAR Area (Sq.mt.)	Total Consumed Additional FAR Area (Sq.mt.)	Trmt (No.)
Ground Floor	55.87	55.87	55.87	55.87	01
First Floor	64.54	64.54	64.54	64.54	00
Terrace Floor	0.00	0.00	0.00	0.00	00
Total :	120.41	120.41	120.41	120.41	01
Total Number of Same Buildings :	1				
Total :	120.41	120.41	120.41	120.41	01

SCHEDULE OF DOOR:

BUILDING NAME	NAME	LENGTH	HEIGHT	NOS
A (RESIDENTIAL)	D2	0.76	2.10	02
A (RESIDENTIAL)	D1	0.91	2.10	06
A (RESIDENTIAL)	D2	0.91	2.10	01
A (RESIDENTIAL)	D	1.22	2.10	01

SCHEDULE OF WINDOW/VENTILATION:

BUILDING NAME	NAME	LENGTH	HEIGHT	NOS
A (RESIDENTIAL)	V	0.61	0.61	02
A (RESIDENTIAL)	W2	0.91	1.20	02
A (RESIDENTIAL)	W1	1.22	1.20	04
A (RESIDENTIAL)	W	1.52	1.20	04

AREA STATEMENT
SARAIKELA NAGAR PANCHAYAT
VERSION NO.: 1.0.65
VERSION DATE: 16/10/2020

PROJECT DETAIL:
Region: JHARKHAND URBAN LOCAL BODIES
District: SERAIKELA
Authority: SARAIKELA NAGAR PANCHAYAT
Inward No: SNPC/BP/0006/W01/2023
Application Type: General Proposal
Project Type: Building Permission
Nature of Development: New
Location of Development Area: Old Area

Plot Use: Residential
Plot SubUse: Bungalow/ Dwelling / Non Apartment
PlotNearby/ReligiousStructure: NA
Plot/SubPlot No.: 249
North: Plot No. - 249
South: Road Width - 4.57
East: Plot No. - 249
West: Plot No. - 249

AREA DETAILS:		SQ.MT.
AREA OF PLOT (Minimum)	(A)	92.75
NET AREA OF PLOT(Gross Plot Area - Deduction from Gross Plot area)	(A-Deductions)	92.75
Deduction for Balance Plot Area(from Gross Plot Area)		
Common Plot		9.29
Total		9.29
BALANCE AREA OF PLOT(Net Plot Area - Recreational/Amenity space)	(A-Deductions)	83.46
PLOT AREA FOR COVERAGE(Net Plot Area)	(A-Deductions)	92.75
Plot Area for FAR (Net Plot Area + Road Widening Area)	(A-Deductions)	92.75
COVERAGE CHECK		
Permissible Coverage area (70.00 %)		64.92
Proposed Coverage Area (60.24 %)		55.87
Total Prop. Coverage Area (60.24 %)		55.87
Balance coverage area (9.76 %)		9.05

FAR CHECK		
Perm. FAR Area (1.500)		139.13
Total Perm. FAR area		139.13
Residential FAR		120.41
Proposed FAR Area		120.41
Total Proposed FAR Area		120.41
Consumed FAR (Factor)		1.30
Balance FAR Area		18.72

BUILT UP AREA CHECK		
Total Proposed BuiltUp Area		120.41
ARCHITECT (Regd)		ABHISHEK TEWARI
ENGINEER (Regd)		
SUPERVISOR (Regd)		
OWNER (Regd)		DIPALI JYOTISHI
DEVELOPMENT AUTHORITY		LOCAL BODY

COLOR INDEX	
PLOT BOUNDARY	Black
ABUTTING ROAD	Red
PROPOSED CONSTRUCTION	Green
COMMON PLOT	Yellow
ROAD WIDENING AREA	Blue
EXISTING (To be retained)	Orange
EXISTING (To be demolished)	Pink

Floor Name	Building Name A (RESIDENTIAL)		Total	
	Proposed Built Up Area (Sq.mt.)	Proposed FAR Area (Sq.mt.)	Total Proposed Built Up Area (Sq.mt.)	Total FAR Area (Sq.mt.)
Ground Floor	55.87	55.87	55.87	55.87
First Floor	64.54	64.54	64.54	64.54
Terrace Floor	0.00	0.00	0.00	0.00
Total :	120.41	120.41	120.41	120.41

Building USE/SUBUSE Details			
Building Name	Building Use	Building SubUse	Building Structure
A (RESIDENTIAL)	Residential	Bungalow/ Dwelling / Non Apartment	Non-Highrise

FAR & Tenement Details (Table 4c-1)						
Building	No. of Same Bldg	Total Built Up Area (Sq.mt.)	Proposed FAR Area (Sq.mt.) Resi.	Total FAR Area (Sq.mt.)	Total Consumed Additional FAR Area (Sq.mt.)	Trmt (No.)
A (RESIDENTIAL)	1	120.41	120.41	120.41	120.41	01
Grand Total :	1	120.41	120.41	120.41	120.41	01

UnitBUA Table for Building :A (RESIDENTIAL)						
FLOOR	Name	UnitBUA Type	UnitBUA Area	Carpet Area	No. of Rooms	No. of Tenement
GROUND FLOOR PLAN	SPLIT A	FLAT	91.95	87.73	5	1
FIRST FLOOR PLAN	SPLIT A	FLAT	0.00	0.00	6	0
Total:	-	-	91.95	87.73	11	1

LTP NAME AND SIGNATURE	STRUCTURAL ENG'S NAME AND SIGNATURE	BUILDER NAME AND SIGNATURE	DIGITAL SIGNATURE
ABHISHEK TEWARI SNPC/ARC/0025/2021			

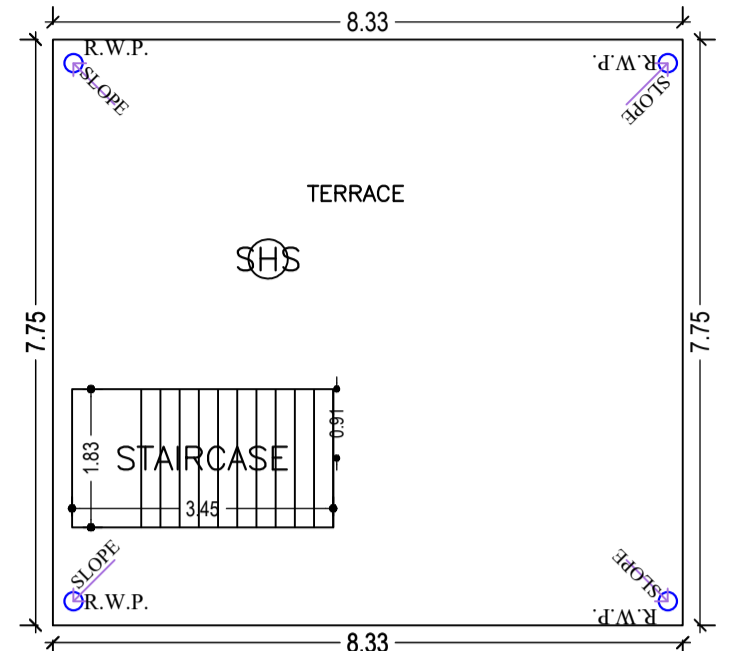
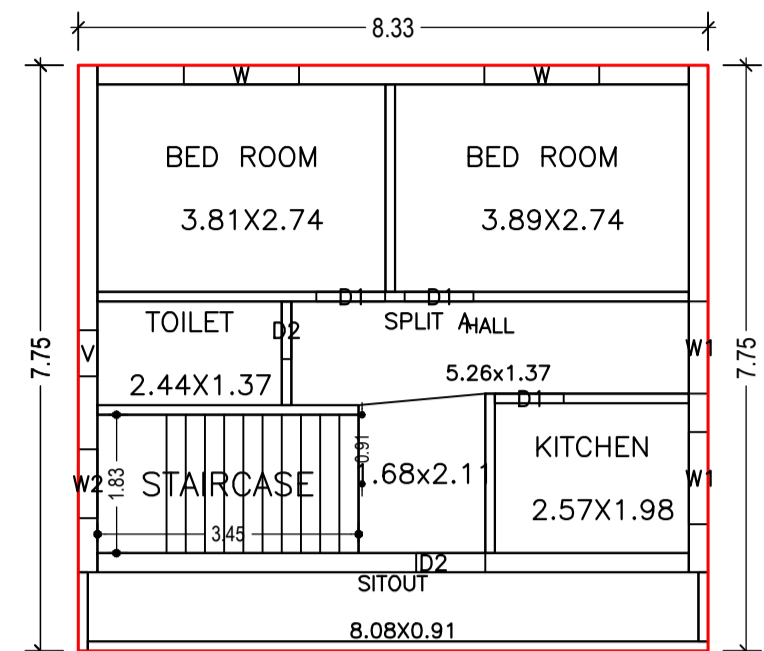
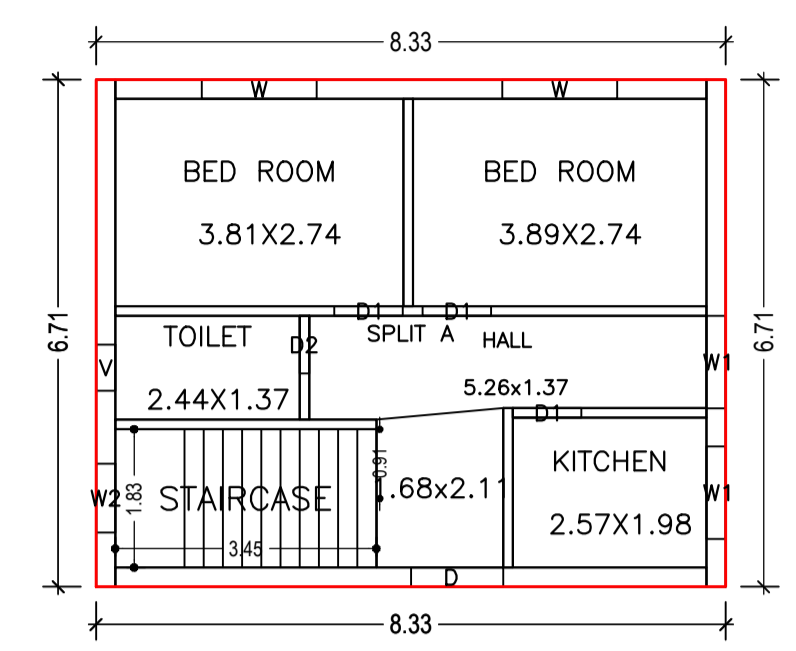
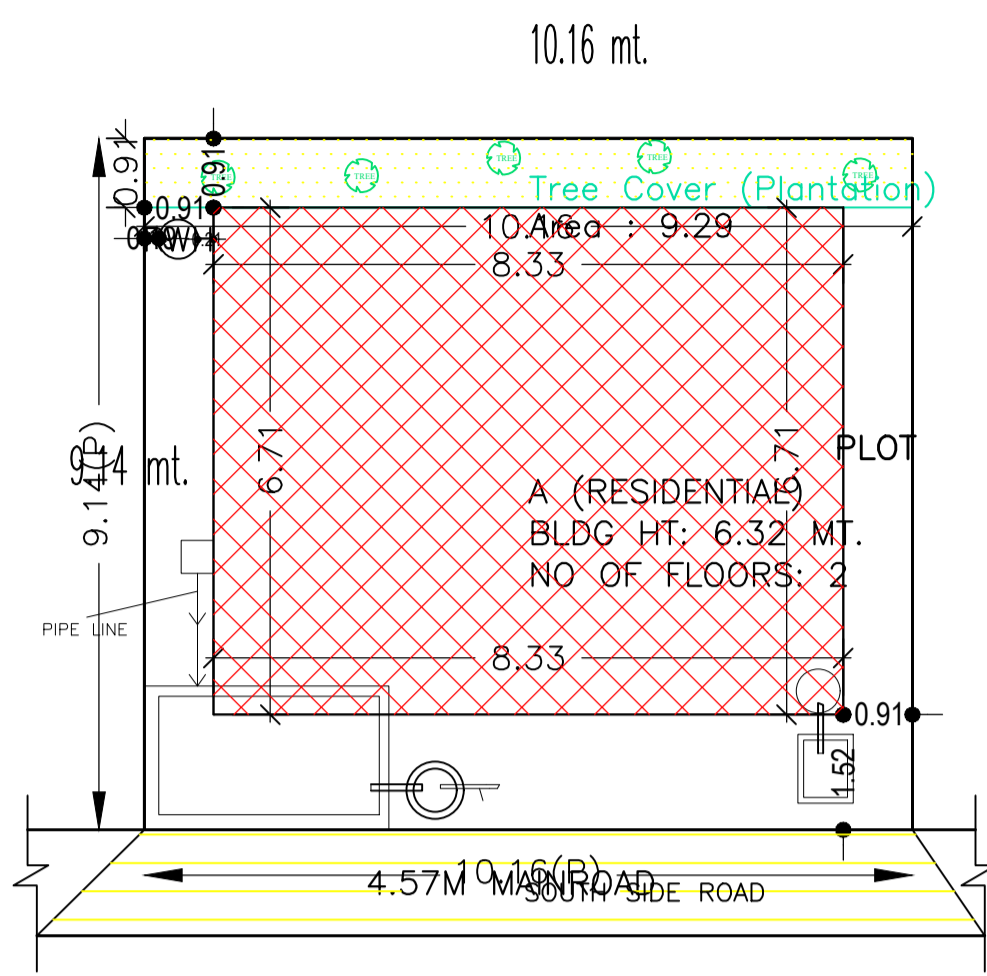

KEY PLAN SOUTH SIDE ROAD & FRONT SCALE:1:100

GROUND FLOOR PLAN (Proposed) (SCALE 1:100)

FIRST FLOOR PLAN (Proposed) (SCALE 1:100)

TERRACE FLOOR PLAN (SCALE 1:100)

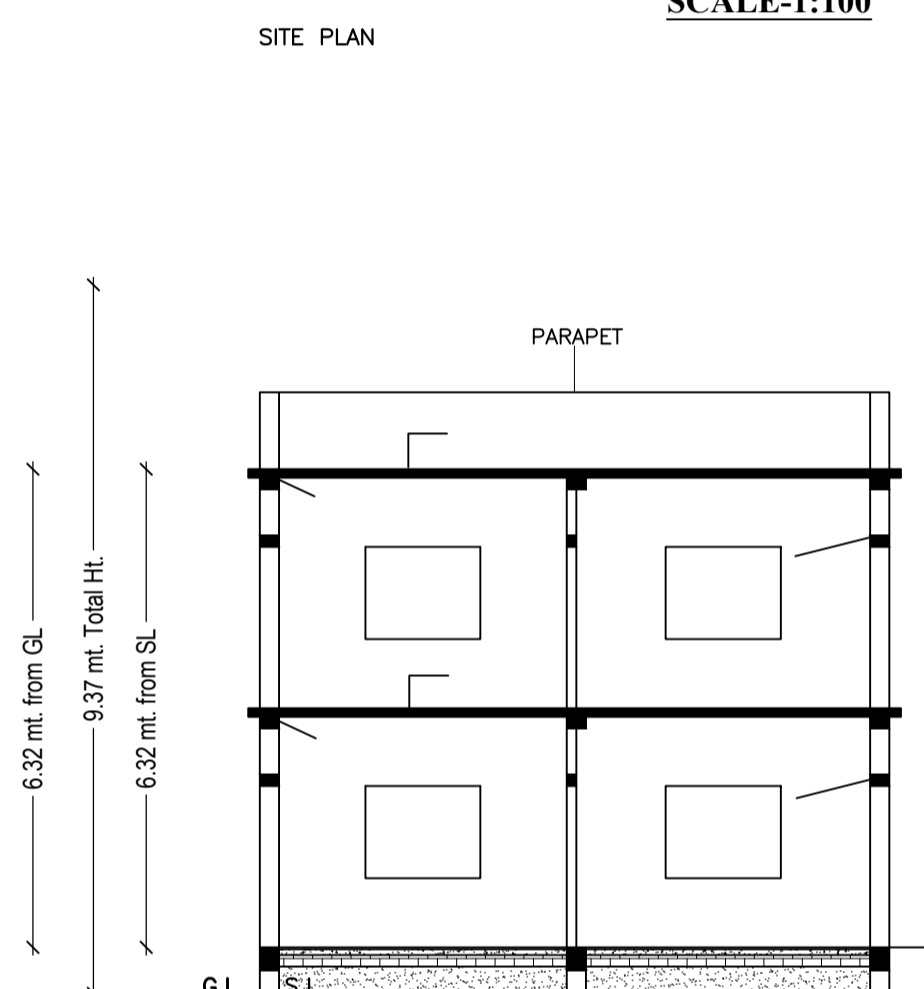

C/S AT A-A

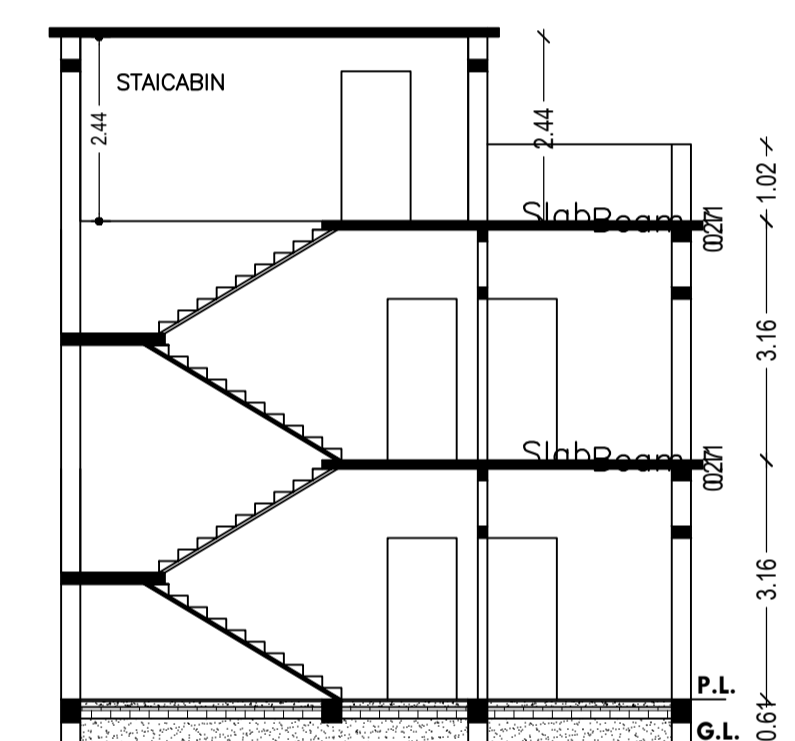

C/S AT B-B

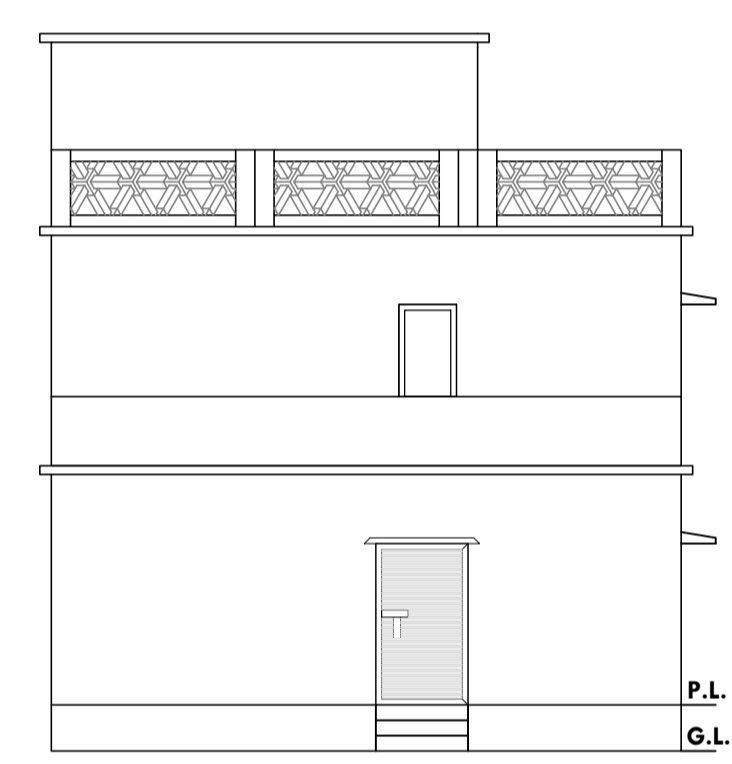

FRONT ELEVATION

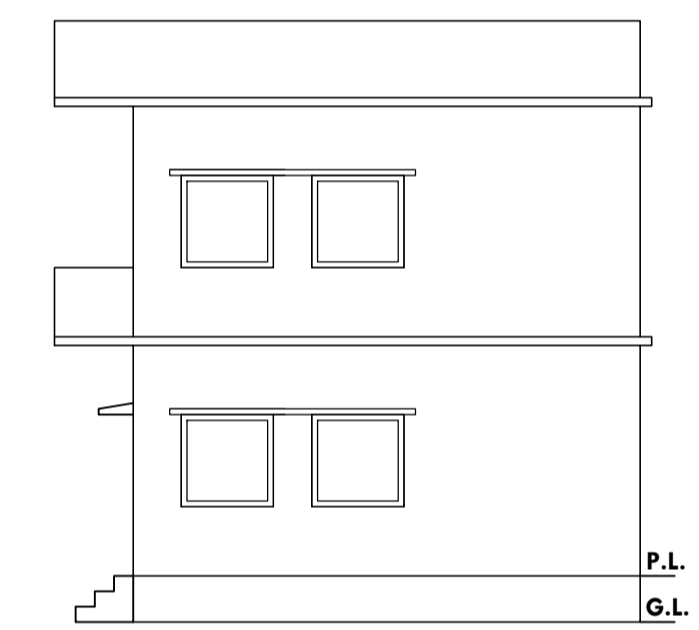

SIDE ELEVATION

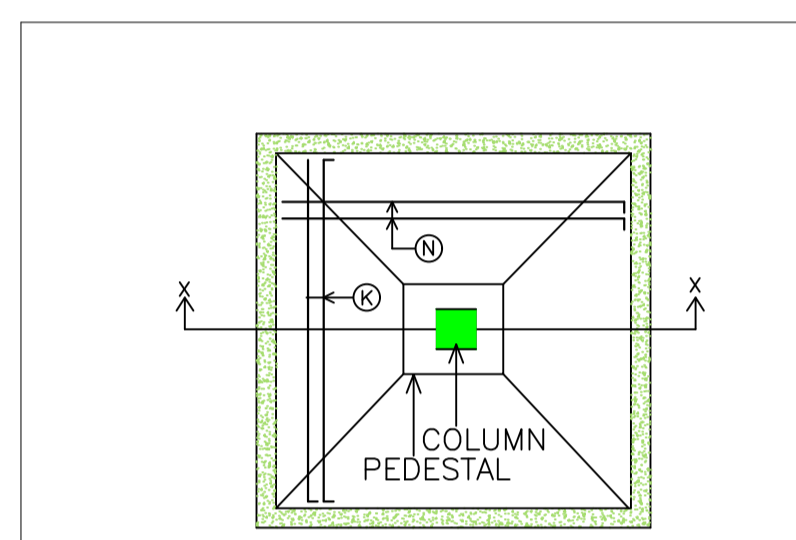

PLAN OF ISOLATED FOOTING

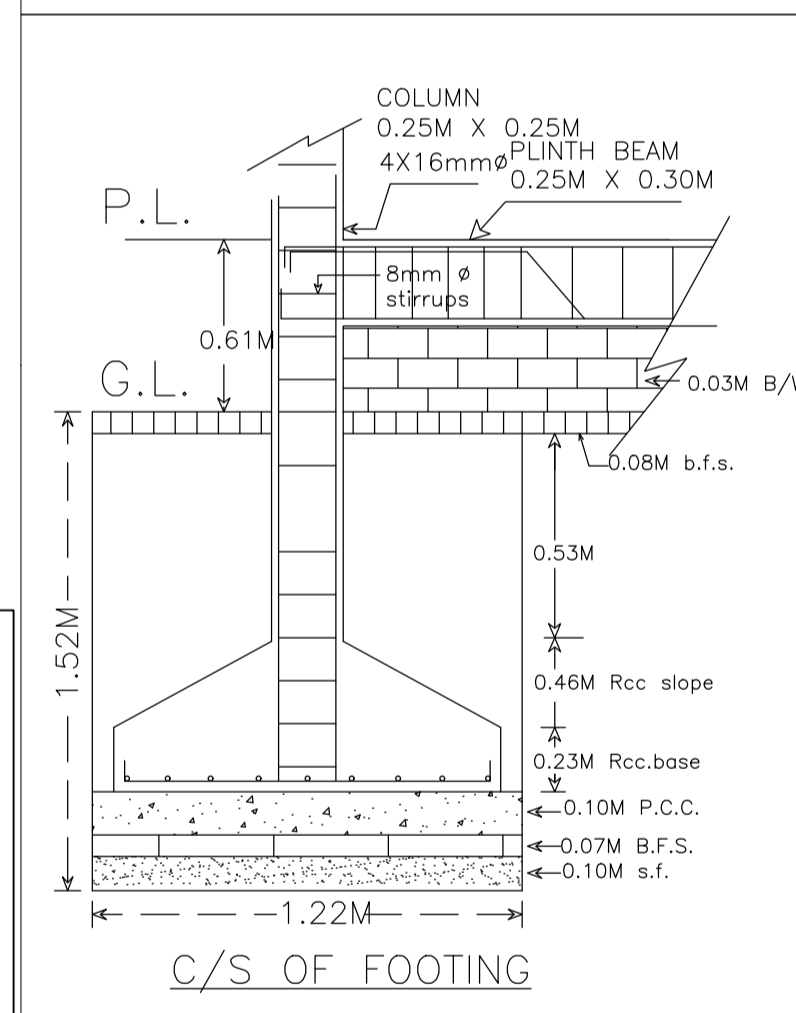

C/S OF FOOTING

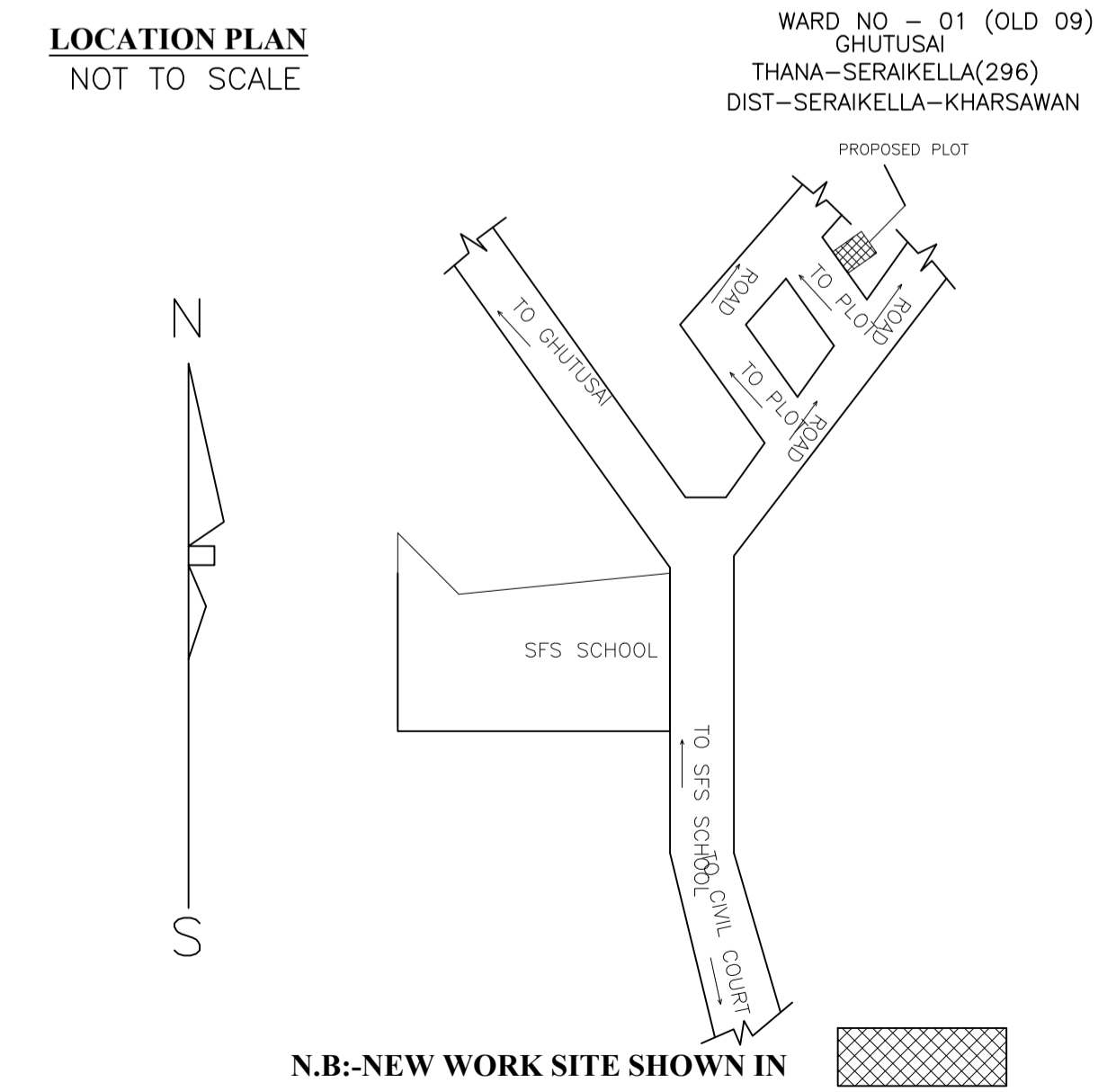

LOCATION PLAN NOT TO SCALE

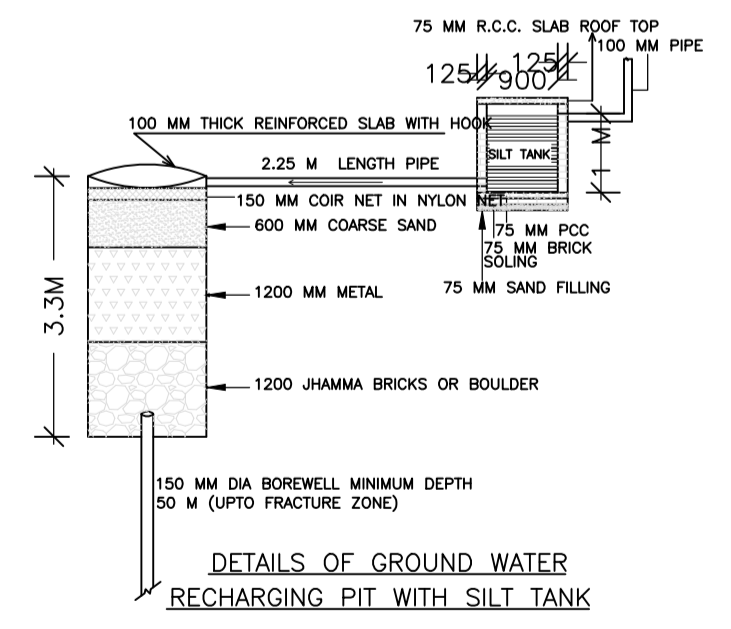

DETAILS OF GROUND WATER RECHARGING PIT WITH SILT TANK

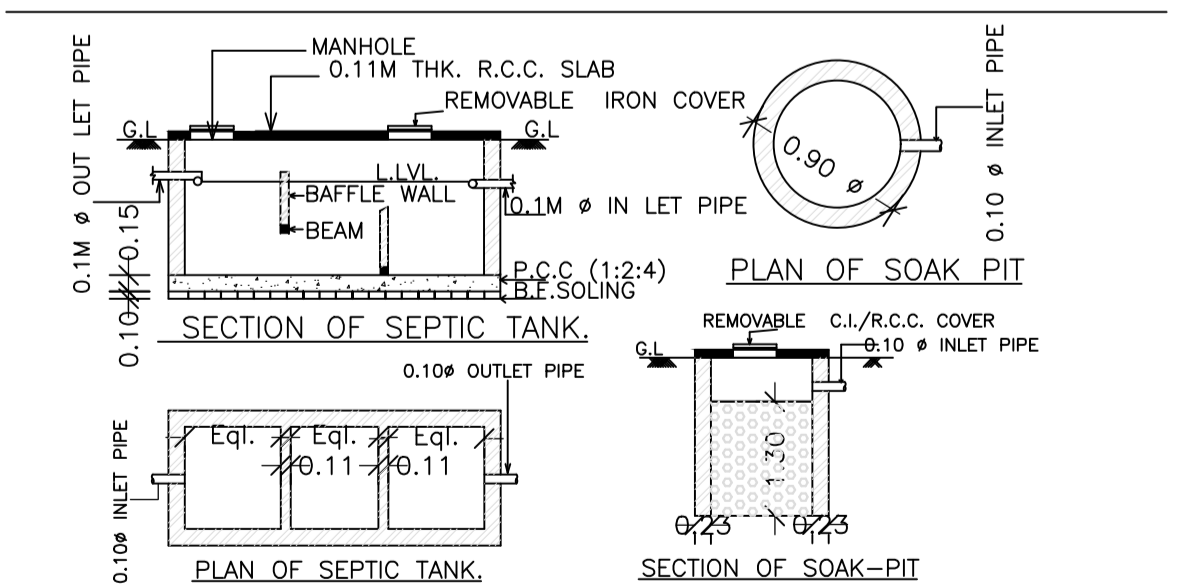

SECTION OF SEPTIC TANK

PLAN OF SOAK PIT

SECTION OF SOAK-PIT