

Proposal Basic Information

Building :LALU KUMAR PASWAN (G1 RESIDENTIAL 2023)

Floor Name	Total Built Up Area (Sq.mt.)	Proposed FAR Area (Sq.mt.) Resi.	Total FAR Area (Sq.mt.)	Total Consumed Additional FAR Area (Sq.mt.)	Tnmt (No.)
Ground Floor	61.90	61.90	61.90	61.90	01
First Floor	27.15	27.15	27.15	27.15	00
Terrace Floor	0.00	0.00	0.00	0.00	00
Total:	89.05	89.05	89.05	89.05	01
Total Number of Same Buildings:	1				
Total:	89.05	89.05	89.05	89.05	01

Proposal File No.	SNPC/BP/0064/W04/2023
Owner Name	LALU KUMAR PASWAN
Khata No	108
Plot No	104
Village Name	Hansahudi
Use	Residential
SubUse	Bungalow/ Dwelling / Non Apartment

AREA STATEMENT SARAIKELA NAGAR PANCHAYAT	VERSION NO.: 1.0.69
PROJECT DETAIL:	VERSION DATE: 16/10/2020
Region :JHARKHAND URBAN LOCAL BODIES	Plot Use: Residential
District: SARAIKELA	Plot SubUse: Bungalow/ Dwelling / Non Apartment
Authority: SARAIKELA NAGAR PANCHAYAT	Plot/Nearby Religious Structure: NA
Inward No: SNPC/BP/0064/W04/2023	Plot/SubPlot No: 104
Application Type: General Proposal	North: Road Width - 3.65
Project Type: Building Permission	South: Plot No - 103
Nature of Development: New	East: Plot No - 104P
Location of Development Area: Old Area	West: Plot No - 104P

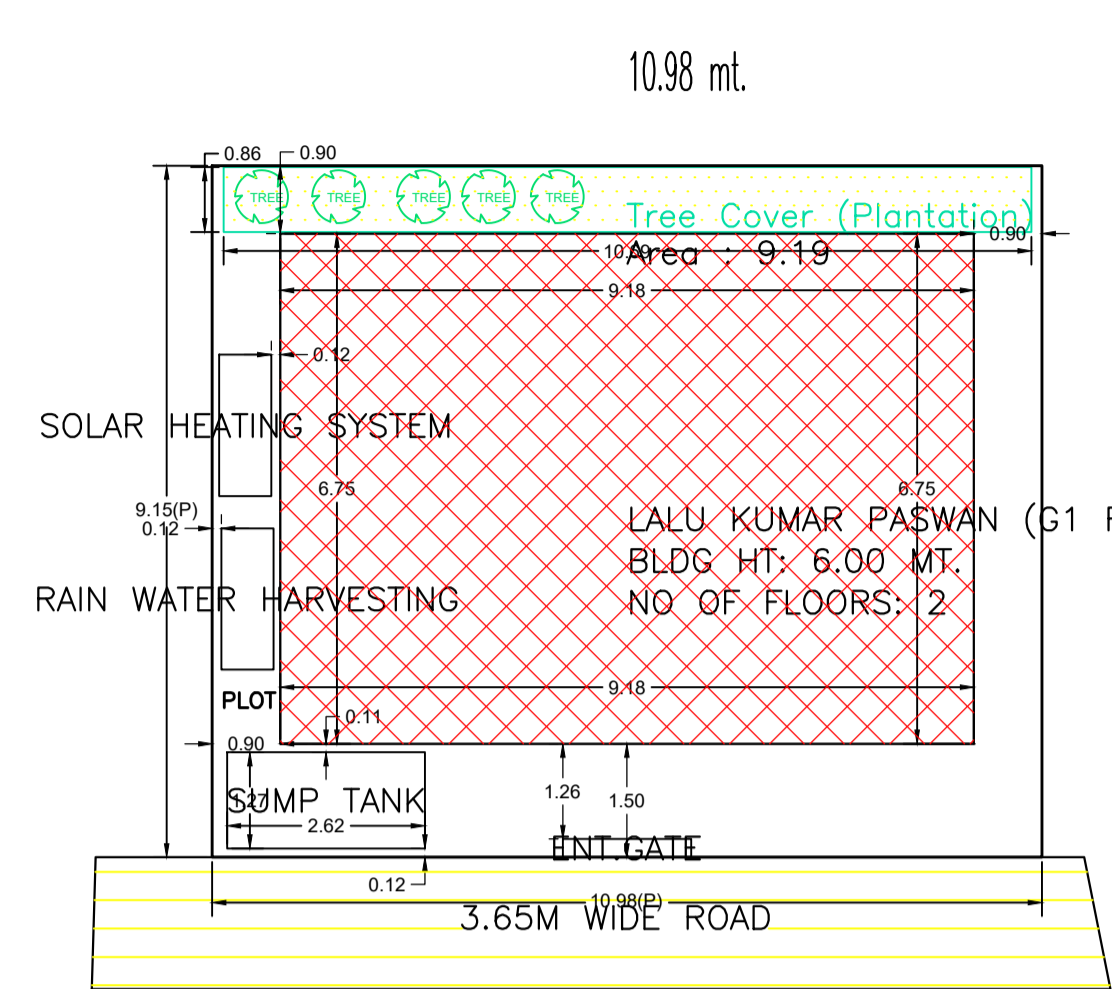

SITE PLAN

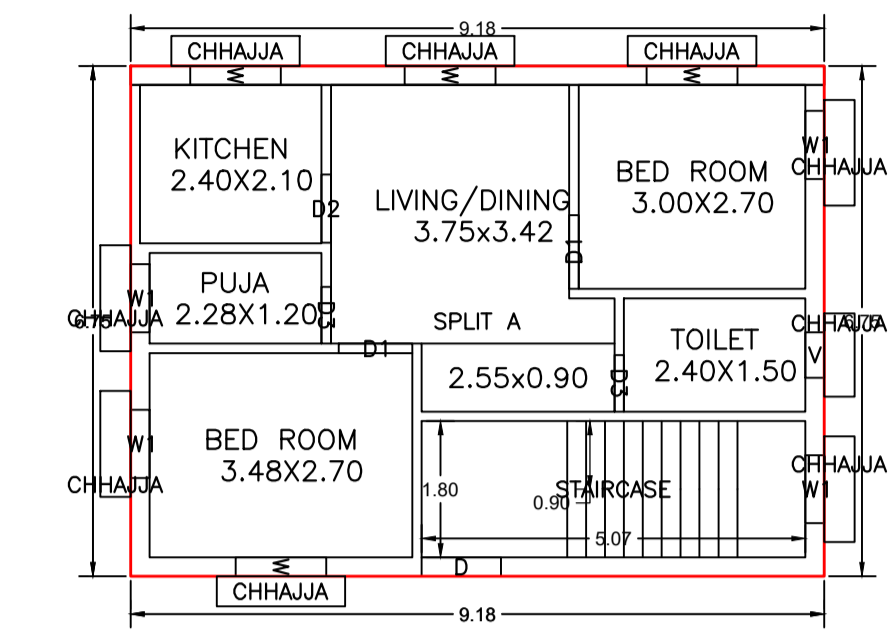

GROUND FLOOR PLAN (Proposed) (SCALE 1:100)

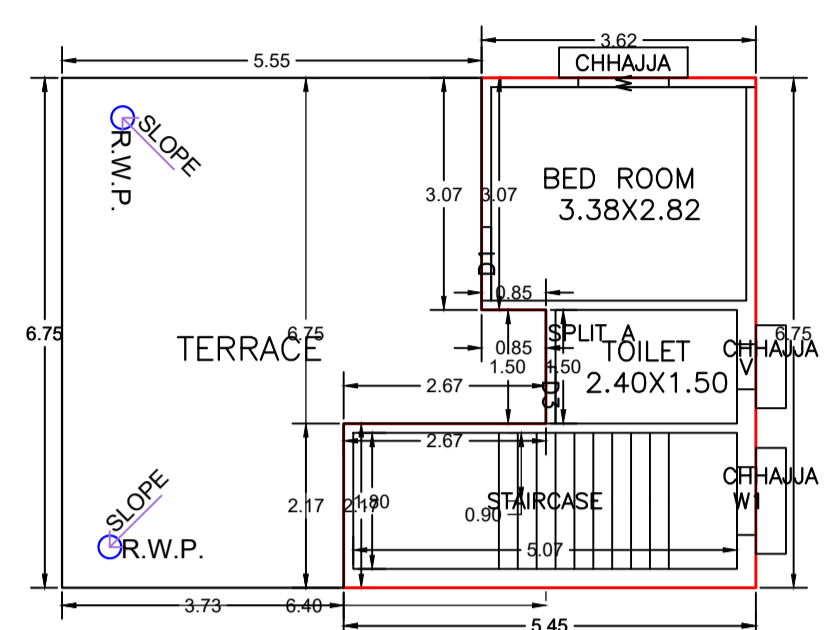

FIRST FLOOR PLAN (Proposed) (SCALE 1:100)

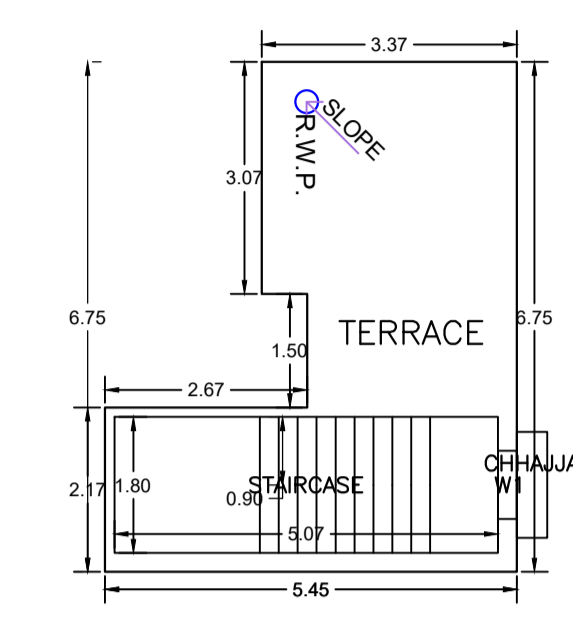

TERRACE FLOOR PLAN (SCALE 1:100)

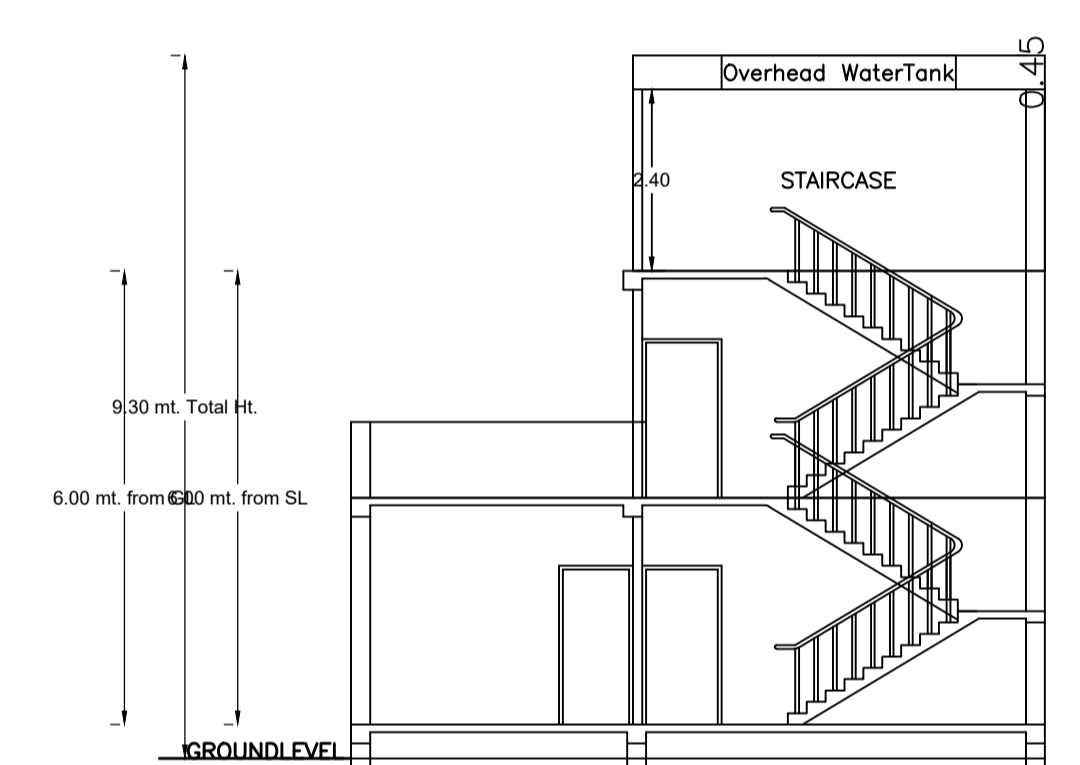

SECTION AT-XX

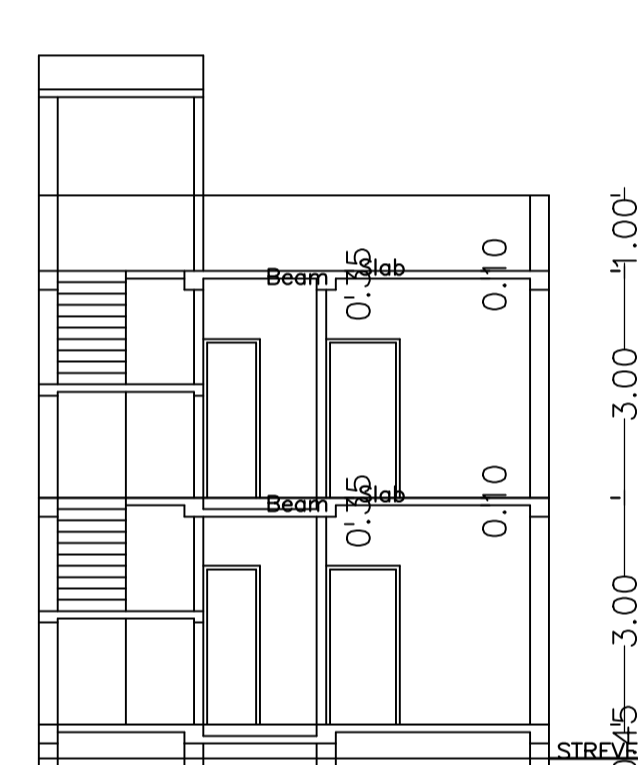

SECTION AT-YY

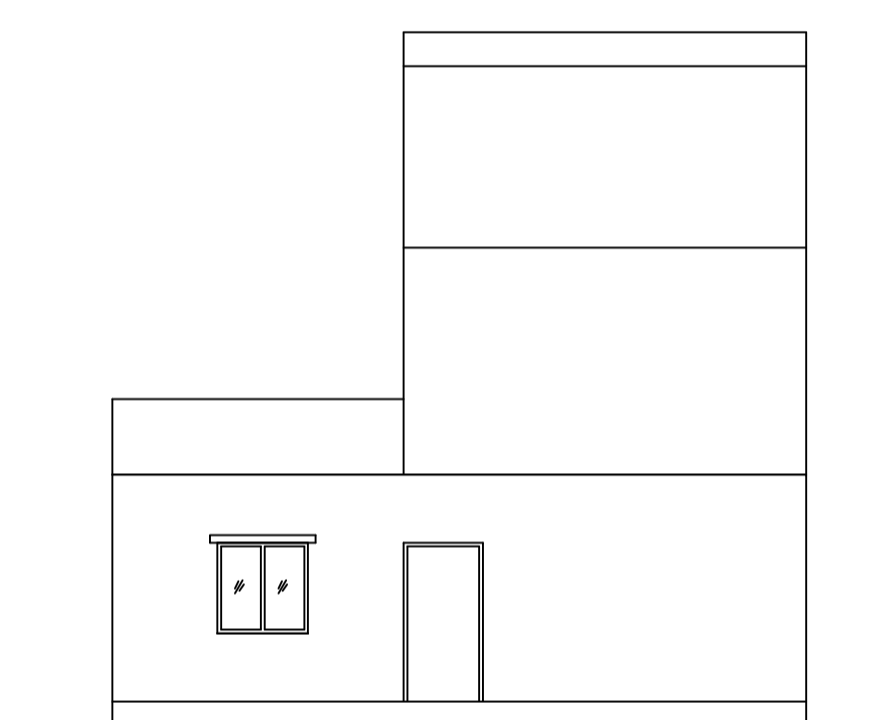

FRONT ELEVATION

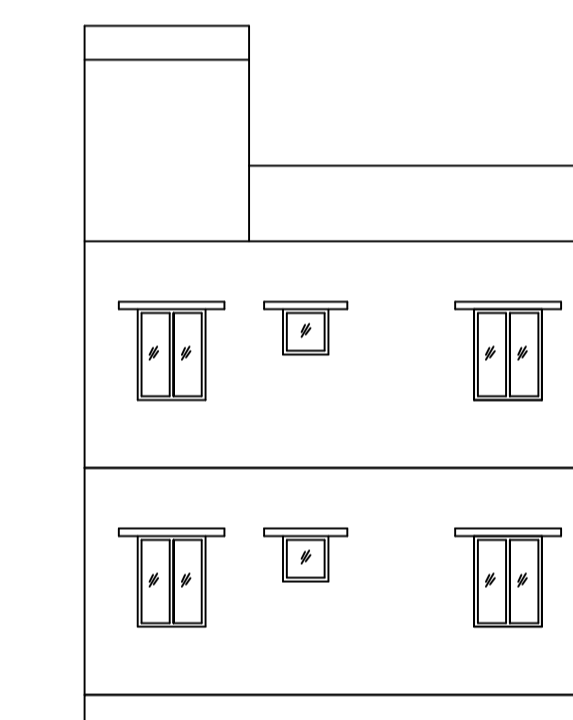

SIDE ELEVATION

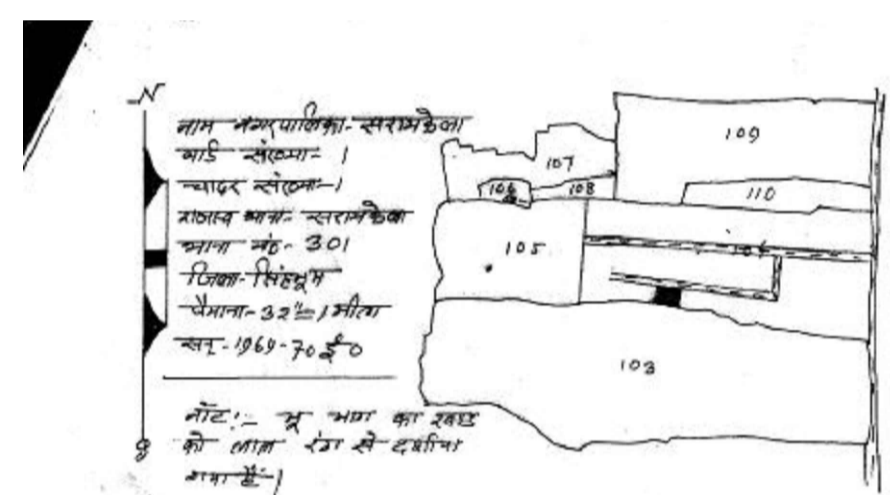

KEY PLAN

SCHEDULE OF DOOR:

BUILDING NAME	NAME	LENGTH	HEIGHT	NOS
LALU KUMAR PASWAN (G1 RESIDENTIAL 2023)	D3	0.75	2.10	03
LALU KUMAR PASWAN (G1 RESIDENTIAL 2023)	D2	0.90	2.10	01
LALU KUMAR PASWAN (G1 RESIDENTIAL 2023)	D1	0.98	2.10	03

SCHEDULE OF WINDOW/VENTILATION:

BUILDING NAME	NAME	LENGTH	HEIGHT	NOS
LALU KUMAR PASWAN (G1 RESIDENTIAL 2023)	V	0.60	1.20	02
LALU KUMAR PASWAN (G1 RESIDENTIAL 2023)	W1	0.90	1.20	06
LALU KUMAR PASWAN (G1 RESIDENTIAL 2023)	W	1.20	1.20	05

AREA OF PLOT (Minimum)	(A)	SQ.MT.
NET AREA OF PLOT (Gross Plot Area - Deduction from Gross Plot area)	(A-Deductions)	100.39
Deduction for Balance Plot Area (from Gross Plot Area)		
Total		9.19
BALANCE AREA OF PLOT (Net Plot Area - Recreational/Amenity space)	(A-Deductions)	91.19
PLOT AREA FOR COVERAGE (Net Plot Area)	(A-Deductions)	100.39
Plot Area for FAR (Net Plot Area + Road Widening Area)	(A-Deductions)	100.39

COVERAGE CHECK		
Permissible Coverage area (70.00 %)		70.27
Proposed Coverage Area (61.66 %)		61.90
Total Prop. Coverage Area (61.66 %)		61.90
Balance coverage area (8.34 %)		8.37

FAR CHECK		
Perm. FAR Area (1.500)		150.58
Total Perm. FAR area		150.58
Residential FAR		89.05
Proposed FAR Area		89.05
Total Proposed FAR Area		89.05
Consumed FAR (Factor)		0.89
Balance FAR Area		61.53

Buildingwise Floor FAR Details

Floor Name	Building Name		Total	
	LALU KUMAR PASWAN (G1 RESIDENTIAL 2023)	Proposed Built Up Area (Sq.mt.)	Proposed FAR Area (Sq.mt.)	Total Proposed Built Up Area (Sq.mt.)
Ground Floor	61.90	61.90	61.90	61.90
First Floor	27.15	27.15	27.15	27.15
Terrace Floor	0.00	0.00	0.00	0.00
Total:	89.05	89.05	89.05	89.05

Building Name	Building Use	Building SubUse	Building Structure
LALU KUMAR PASWAN (G1 RESIDENTIAL 2023)	Residential	Bungalow/ Dwelling / Non Apartment	Non-Highrise

FAR & Tenement Details (Table 4c-1)

Building	No. of Same Bldg	Total Built Up Area (Sq.mt.)	Proposed FAR Area (Sq.mt.) Resi.	Total FAR Area (Sq.mt.)	Total Consumed Additional FAR Area (Sq.mt.)	Tnmt (No.)
LALU KUMAR PASWAN (G1 RESIDENTIAL 2023)	1	89.05	89.05	89.05	89.05	01
Grand Total:	1	89.05	89.05	89.05	89.05	01

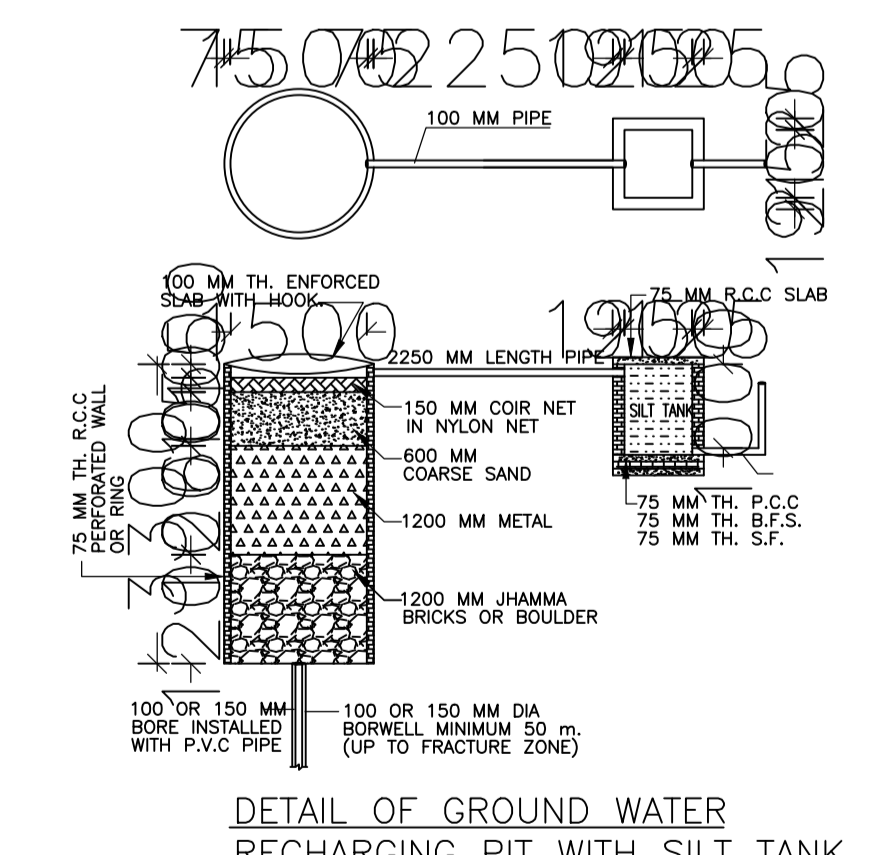
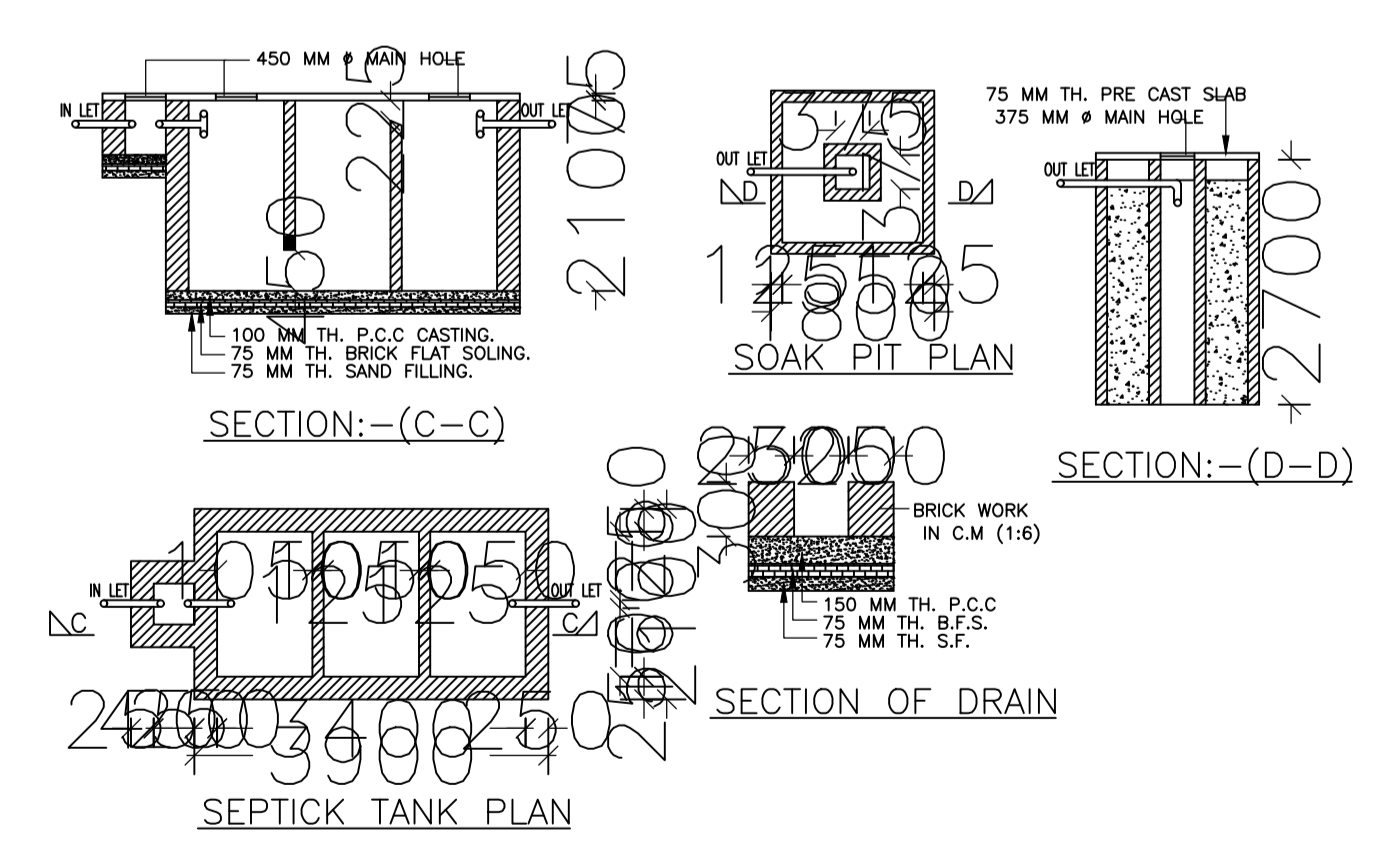

UnitBUA Table for Building :LALU KUMAR PASWAN (G1 RESIDENTIAL 2023)

FLOOR	Name	UnitBUA Type	UnitBUA Area	Carpet Area	No. of Rooms	No. of Tenement
GROUND FLOOR PLAN	SPLIT A	FLAT	89.05	86.34	6	1
FIRST FLOOR PLAN	SPLIT A	FLAT	0.00	0.00	2	0
Total:	-	-	89.05	86.34	8	1

LTP NAME AND SIGNATURE

ABHISHEK KUMAR SAHOO SNPC/ENG/0035/2022	STRUCTURAL ENG'S NAME AND SIGNATURE	BUILDER NAME AND SIGNATURE	DIGITAL SIGNATURE
--	-------------------------------------	----------------------------	-------------------