

9.15 mt.

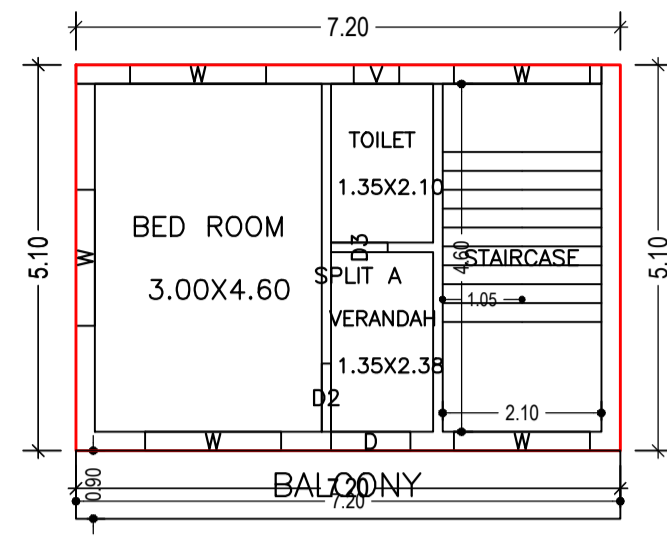

FIRST FLOOR PLAN (Proposed) (SCALE 1:100)

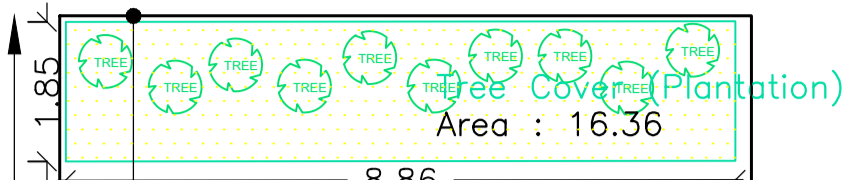
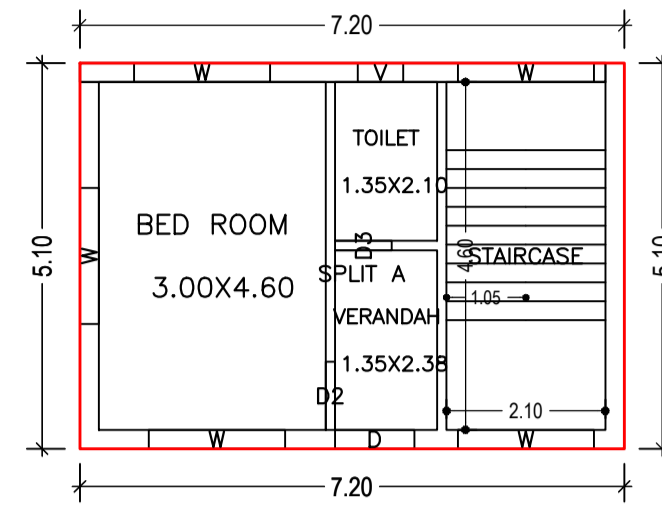

GROUND FLOOR PLAN (Proposed) (SCALE 1:100)

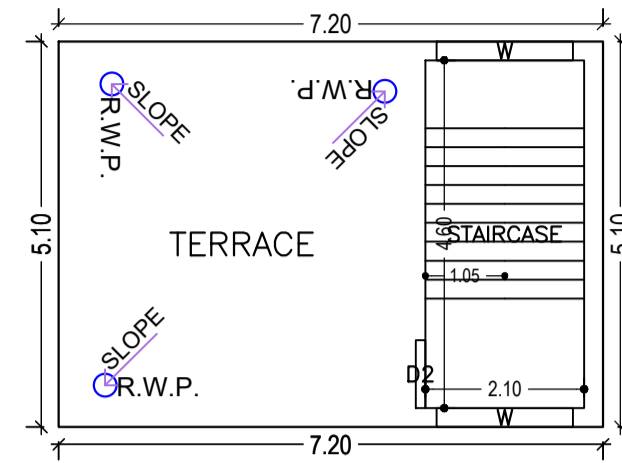

TERRACE FLOOR PLAN (SCALE 1:100)

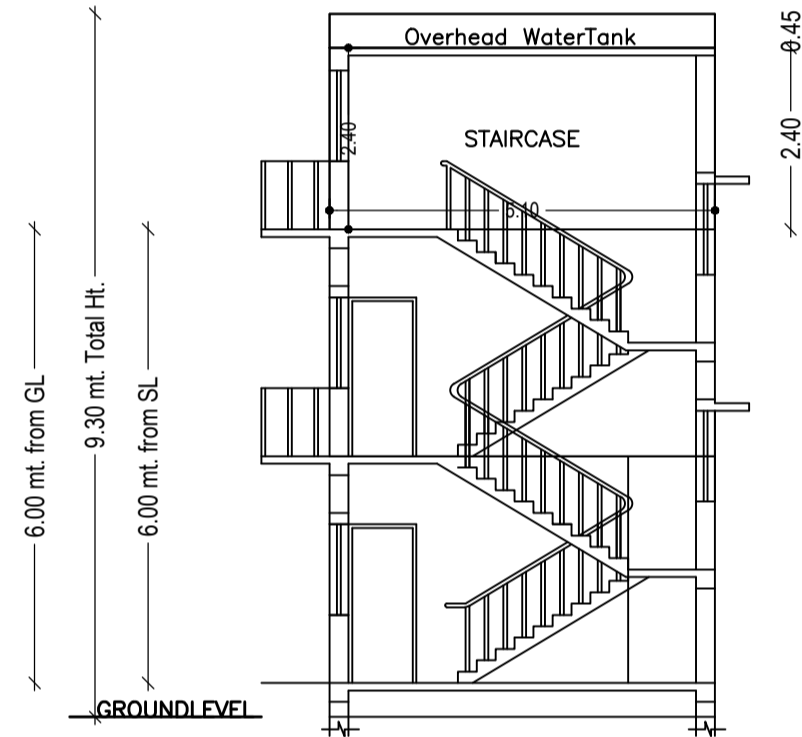

SECTION AT-XX

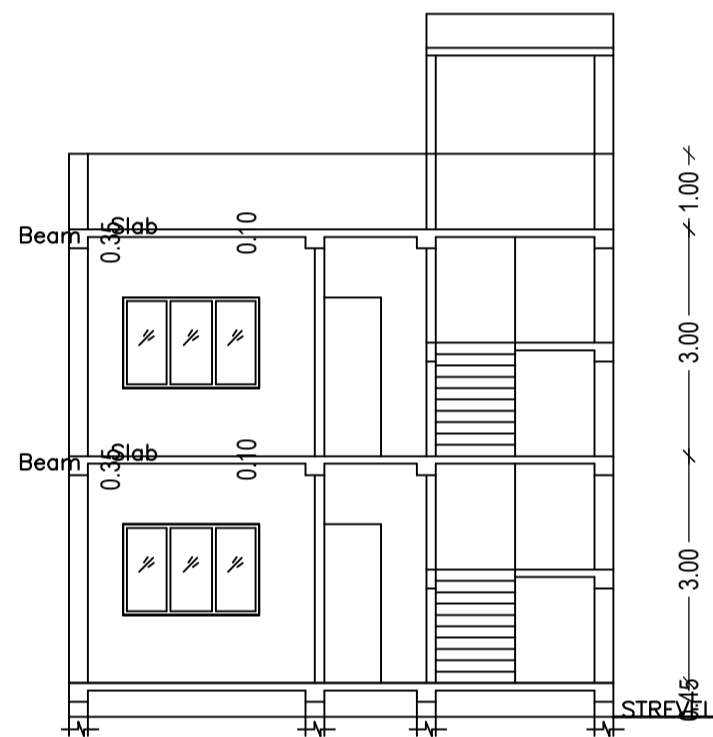

SECTION AT-YY

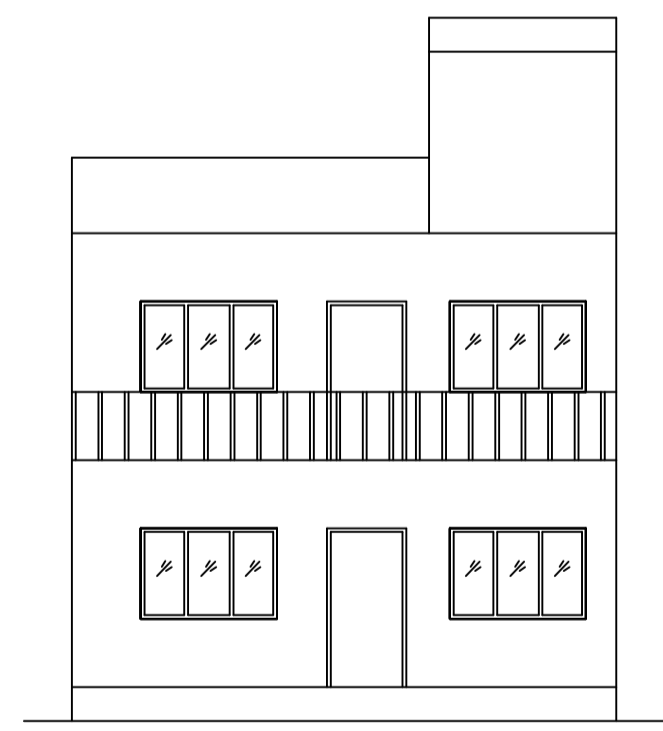

FRONT ELEVATION

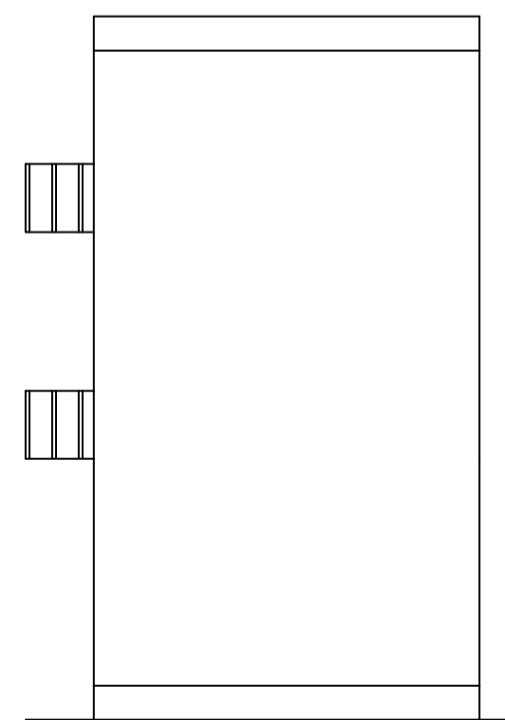

SIDE ELEVATION

Building :MEENKETAN PRADHAN (FLOOR G1)

Floor Name	Total Built Up Area (Sq.mt.)	Deductions (Area in Sq.mt.)	Proposed FAR Area (Sq.mt.)	Total FAR Area (Sq.mt.)	Total Consumed Additional FAR Area (Sq.mt.)	Tnmt (No.)
Ground Floor	36.72	0.00	36.72	36.72	36.72	01
First Floor	43.20	3.24	39.96	39.96	39.96	00
Terrace Floor	0.00	0.00	0.00	0.00	0.00	00
Total :	79.92	3.24	76.68	76.68	76.68	01
Total Number of Same Buildings :	1					
Total :	79.92	3.24	76.68	76.68	76.68	01

SCHEDULE OF DOOR:

BUILDING NAME	NAME	LENGTH	HEIGHT	NOS
MEENKETAN PRADHAN (FLOOR G1)	D3	0.75	2.10	02
MEENKETAN PRADHAN (FLOOR G1)	D2	0.90	2.10	02
MEENKETAN PRADHAN (FLOOR G1)	D	1.05	2.10	02

SCHEDULE OF WINDOW/VENTILATION:

BUILDING NAME	NAME	LENGTH	HEIGHT	NOS
MEENKETAN PRADHAN (FLOOR G1)	V	0.60	1.20	02
MEENKETAN PRADHAN (FLOOR G1)	W	1.80	1.20	12

Balcony Calculations Table

FLOOR	SIZE	AREA	TOTAL AREA
FIRST FLOOR PLAN	0.90 X 7.20 X 1 X 1	6.48	6.48
Total			6.48

UnitBUA Table for Building :MEENKETAN PRADHAN (FLOOR G1)

FLOOR	Name	UnitBUA Type	UnitBUA Area	Carpet Area	No. of Rooms	No. of Tenement
FIRST FLOOR PLAN	SPLIT A	FLAT	0.00	0.00	3	0
GROUND FLOOR PLAN	SPLIT A	FLAT	79.92	69.97	3	1
Total:			79.92	69.97	6	1

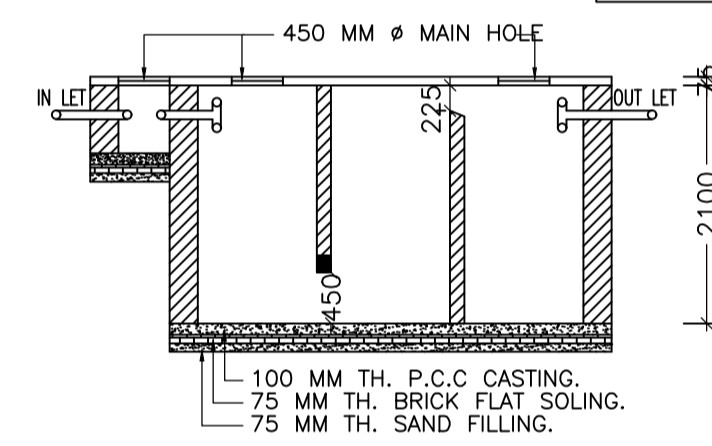

SECTION:- (C-C)

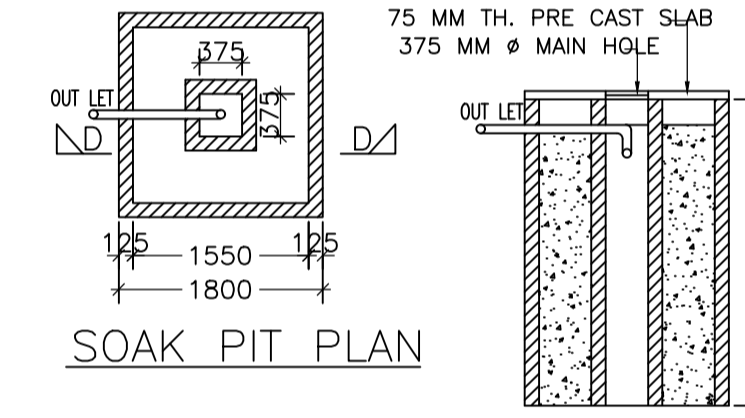

SOAK PIT PLAN

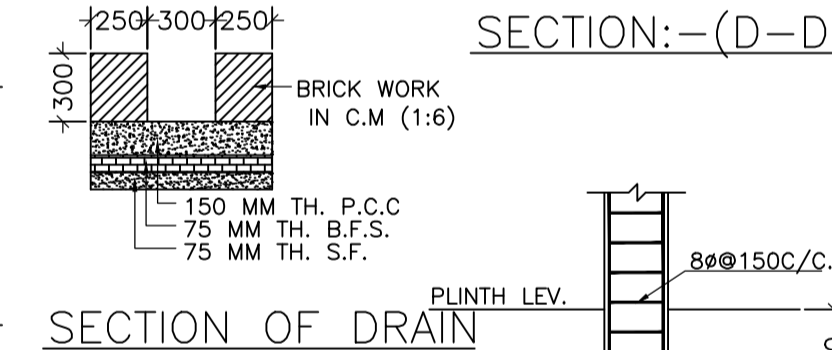

SECTION:- (D-D)

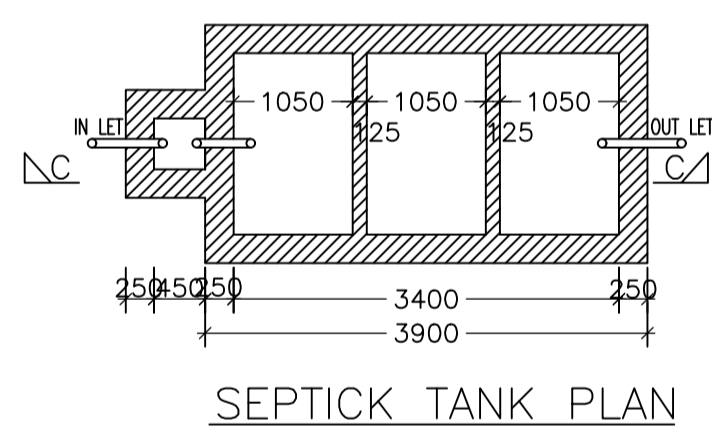

SEPTICK TANK PLAN

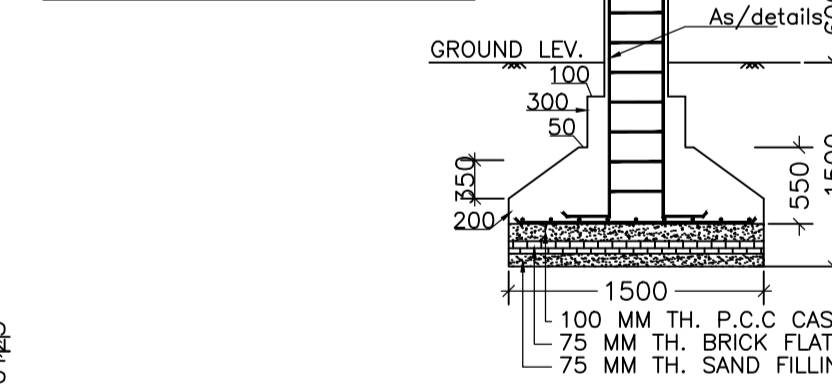

SECTION:- (B-B)

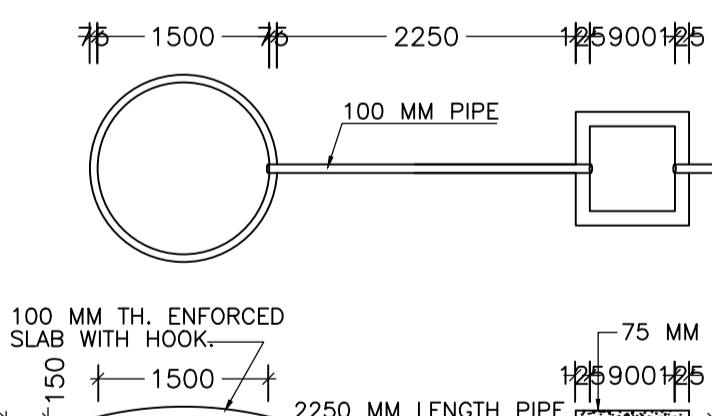

DETAIL OF GROUND WATER RECHARGING PIT WITH SILT TANK

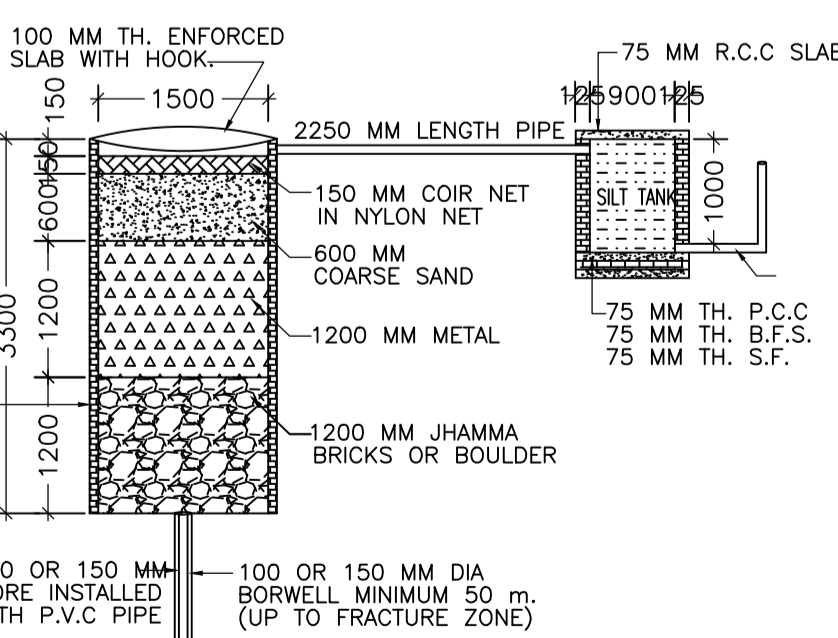

FOUNDATION PLAN OF CLOUMN

Proposal Basic Information

Proposal File No.	SNPC/BP/0055/W04/2023
Owner Name	MEENKETAN PRADHAN
Khata No	32
Plot No	491
Village Name	Hansahudi
Use	Residential
SubUse	Bungalow/ Dwelling / Non Apartment

AREA STATEMENT SARAIKELA NAGAR PANCHAYAT	VERSION NO. : 1.0.66
PROJECT DETAIL:	VERSION DATE: 16/10/2020
Region: JHARKHAND URBAN LOCAL BODIES	Plot Use: Residential
District: SERAIKELA	Plot SubUse: Bungalow/ Dwelling / Non Apartment
Authority: SARAIKELA NAGAR PANCHAYAT	PlotNearby/ReligiousStructure: NA
Inward No: SNPC/BP/0055/W04/2023	Plot/SubPlot No: 491
Application Type: General Proposal	North: Plot No. - ABHAY PATHNAYAK
Project Type: Building Permission	South: Road Width - 3.65
Nature of Development: New	East: Plot No. - NIMENDU DAS
Location of Development Area: Old Area	West: Plot No. - GURU CHARAN MOHAPATRA

AREA DETAILS:	AREA	SQ.MT.
AREA OF PLOT (Minimum)	(A)	324.16
NET AREA OF PLOT(Gross Plot Area - Deduction from Gross Plot area)	(A-Deductions)	324.16
Deduction for Balance Plot Area(from Gross Plot Area)		
Common Plot		16.36
Total		16.36
BALANCE AREA OF PLOT(Net Plot Area - Recreational/Amenity space)	(A-Deductions)	307.80
PLOT AREA FOR COVERAGE(Net Plot Area)	(A-Deductions)	324.16
Plot Area for FAR (Net Plot Area + RoadWidening Area)	(A-Deductions)	324.16

COVERAGE CHECK	PERMISSIBLE COVERAGE AREA (%)	PROPOSED COVERAGE AREA (%)	TOTAL PROP. COVERAGE AREA (%)	BALANCE COVERAGE AREA (%)
	60.00 %	11.33 %	11.33 %	48.67 %
	194.50	36.72	36.72	157.78

FAR CHECK	PERM. FAR AREA	TOTAL PERM. FAR AREA	RESIDENTIAL FAR	PROPOSED FAR AREA	TOTAL PROPOSED FAR AREA	CONSUMED FAR (FACTOR)	BALANCE FAR AREA
	1500	486.24	76.68	76.68	76.68	0.24	409.56
BUILT UP AREA CHECK							
Total Proposed BuiltUp Area		79.92					

ARCHITECT (Regd)	ABHISHEK KUMAR SAHOO
ENGINEER (Regd)	
SUPERVISOR (Regd)	
OWNER (Regd)	MEENKETAN PRADHAN
DEVELOPMENT AUTHORITY	
	LOCAL BODY

Floor Name	Building Name	Total
	MEENKETAN PRADHAN (FLOOR G1)	
	Proposed Built Up Area (Sq.mt.)	Total Proposed Built Up Area (Sq.mt.)
	Proposed FAR Area (Sq.mt.)	Total FAR Area (Sq.mt.)
Ground Floor	36.72	36.72
First Floor	43.20	39.96
Terrace Floor	0.00	0.00
Total :	79.92	76.68

Building Name	Building Use	Building SubUse	Building Structure
	Residential	Bungalow/ Dwelling / Non Apartment	Non-Highrise

Building	No. of Same Bldg	Total Built Up Area (Sq.mt.)	Deductions (Area in Sq.mt.)	Proposed FAR Area (Sq.mt.)	Total FAR Area (Sq.mt.)	Total Consumed Additional FAR Area (Sq.mt.)	Tnmt (No.)
MEENKETAN PRADHAN (FLOOR G1)	1	79.92	3.24	76.68	76.68	76.68	01
Grand Total :	1	79.92	3.24	76.68	76.68	76.68	01

LTP NAME AND SIGNATURE	STRUCTURAL ENG'S NAME AND SIGNATURE	BUILDER NAME AND SIGNATURE	DIGITAL SIGNATURE
ABHISHEK KUMAR SAHOO SNPC/ENG/0035/2022			