

Proposal Basic Information	
Proposal File No.	SNPC/BP/0003/W04/2024
Owner Name	NIRANJAN KUMAR ADITYA AND JANMAJAY ADITYA
Khata No	62
Plot No	62
Village Name	Hansahudi
Use	Residential
SubUse	Bungalow/ Dwelling / Non Apartment

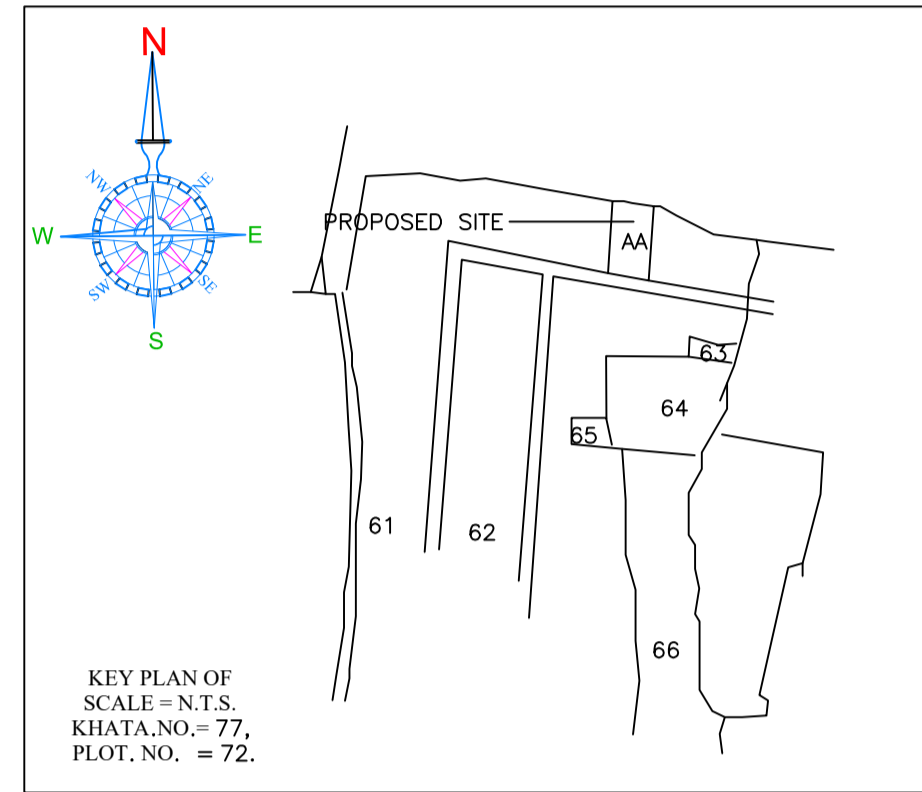

FAR & Tenement Details (Table 4c-1)

Building	No. of Same Bldg	Total Built Up Area (Sq.mt.)	Deductions (Area in Sq.mt.)		Proposed FAR Area (Sq.mt.)	Total FAR Area (Sq.mt.)	Total Consumed Additional FAR Area (Sq.mt.)	Trmt (No.)
			Balcony	Resi.				
A (RESIDENTIAL)	1	206.38	2.28		204.10	204.10	204.10	01
Grand Total :	1	206.38	2.28		204.10	204.10	204.10	01

Building USE/SUBUSE Details

Building Name	Building Use	Building SubUse	Building Structure
A (RESIDENTIAL)	Residential	Bungalow/ Dwelling / Non Apartment	Non-Highrise

Buildingwise Floor FAR Details

Floor Name	Building Name A (RESIDENTIAL)		Total	
	Proposed Built Up Area (Sq.mt.)	Proposed FAR Area (Sq.mt.)	Total Proposed Built Up Area (Sq.mt.)	Total FAR Area (Sq.mt.)
Ground Floor	100.91	100.91	100.91	100.91
First Floor	105.47	103.19	105.47	103.19
Terrace Floor	0.00	0.00	0.00	0.00
Total :	206.38	204.10	206.38	204.10

COLOR INDEX	
PLOT BOUNDARY	[Red Line]
ABUTTING ROAD	[Green Line]
PROPOSED CONSTRUCTION	[Blue Line]
COMMON PLOT	[Yellow Line]
ROAD WIDENING AREA	[Orange Line]
EXISTING (To be retained)	[Purple Line]
EXISTING (To be demolished)	[Pink Line]

Building :A (RESIDENTIAL)

Floor Name	Total Built Up Area (Sq.mt.)	Deductions (Area in Sq.mt.)		Proposed FAR Area (Sq.mt.)	Total FAR Area (Sq.mt.)	Total Consumed Additional FAR Area (Sq.mt.)	Trmt (No.)
		Balcony	Resi.				
Ground Floor	100.91	0.00		100.91	100.91	100.91	01
First Floor	105.47	2.28		103.19	103.19	103.19	00
Terrace Floor	0.00	0.00		0.00	0.00	0.00	00
Total :	206.38	2.28		204.10	204.10	204.10	01
Total Number of Same Buildings :	1						
Total :	206.38	2.28		204.10	204.10	204.10	01

SCHEDULE OF DOOR:

BUILDING NAME	NAME	LENGTH	HEIGHT	NOS
A (RESIDENTIAL)	D2	0.75	2.10	04
A (RESIDENTIAL)	D1	0.90	2.10	04
A (RESIDENTIAL)	D	1.05	2.10	08
A (RESIDENTIAL)	G	1.20	2.10	04

SCHEDULE OF WINDOW/VENTILATION:

BUILDING NAME	NAME	LENGTH	HEIGHT	NOS
A (RESIDENTIAL)	V	0.60	1.20	04
A (RESIDENTIAL)	W1	1.20	1.20	14

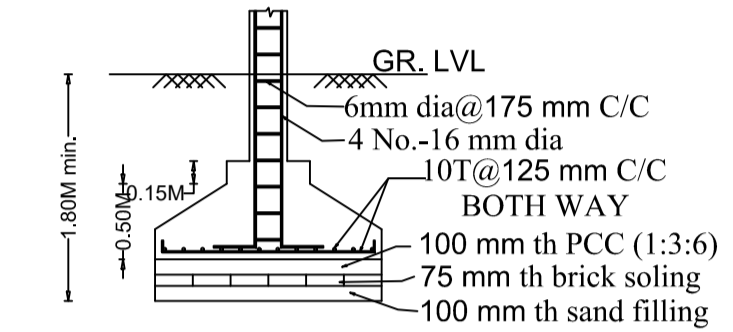

Column size-0.25Mx0.25M. FOUNDATION SCALE = 1:50

Balcony Calculations Table

FLOOR	SIZE	AREA	TOTAL AREA
FIRST FLOOR PLAN	1.18 X 3.89 X 1 X 1	4.57	4.57
Total			4.57

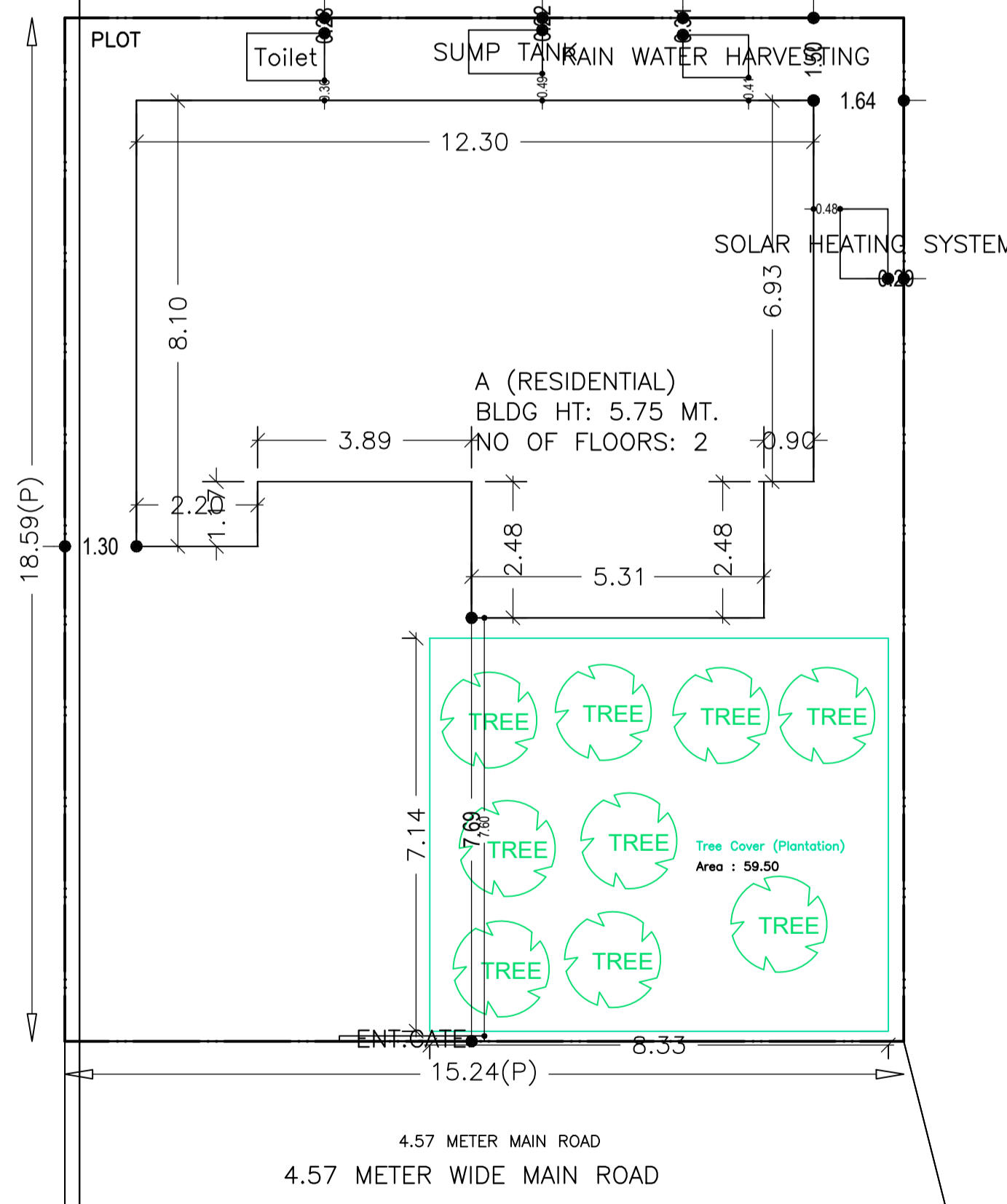

PROPOSED PLAN SCALE- 1:100

SITE PLAN

AREA STATEMENT		VERSION NO. : 1.0.68
SARAIKELA NAGAR PANCHAYAT		VERSION DATE: 16/10/2020
PROJECT DETAIL:		
Region: JHARKHAND URBAN LOCAL BODIES	Plot Use: Residential	
District: SARAIKELA	Plot SubUse: Bungalow/ Dwelling / Non Apartment	
Authority: SARAIKELA NAGAR PANCHAYAT	Plot/Neary/Religious/Structure: NA	
Inward No: SNPC/BP/0003/W04/2024	Plot/SubPlot No: 62	
Application Type: General Proposal	North: Road No. - SIMANA OF BADBIL	
Project Type: Building Permission	South: Road Width - 3.66	
Nature of Development: New	East: Plot No. - RAMESHWAR GOPE	
Location of Development Area: Old Area	West: Plot No. - 62	
AREA DETAILS:		
AREA OF PLOT (Minimum)	(A)	283.35
NET AREA OF PLOT (Gross Plot Area - Deduction from Gross Plot area)	(A-Deductions)	283.35
Deduction for Balance Plot Area (from Gross Plot Area)		
Common Plot		59.50
Total		59.50
BALANCE AREA OF PLOT (Net Plot Area - Recreational/Amenity space)	(A-Deductions)	223.85
PLOT AREA FOR COVERAGE (Net Plot Area)	(A-Deductions)	283.35
Plot Area for FAR (Net Plot Area + Road Widening Area)	(A-Deductions)	283.35
COVERAGE CHECK		
Permissible Coverage area (60.00 %)		170.01
Proposed Coverage Area (35.61 %)		100.91
Total Prop. Coverage Area (35.61 %)		100.91
Balance coverage area (24.39 %)		69.10
FAR CHECK		
Perm. FAR Area (1.500)		425.03
Total Perm. FAR area		425.03
Residential FAR		204.11
Proposed FAR Area		204.11
Total Proposed FAR Area		204.11
Consumed FAR (Factor)		0.72
Balance FAR Area		220.92
BUILT UP AREA CHECK		
Total Proposed BuiltUp Area		206.38
ARCHITECT (Regd)	ABHISHEK TEWARI	
ENGINEER (Regd)		
SUPERVISOR (Regd)		
OWNER (Regd)	NIRANJAN KUMAR ADITYA AND JANMAJAY ADITYA	
DEVELOPMENT AUTHORITY	LOCAL BODY	

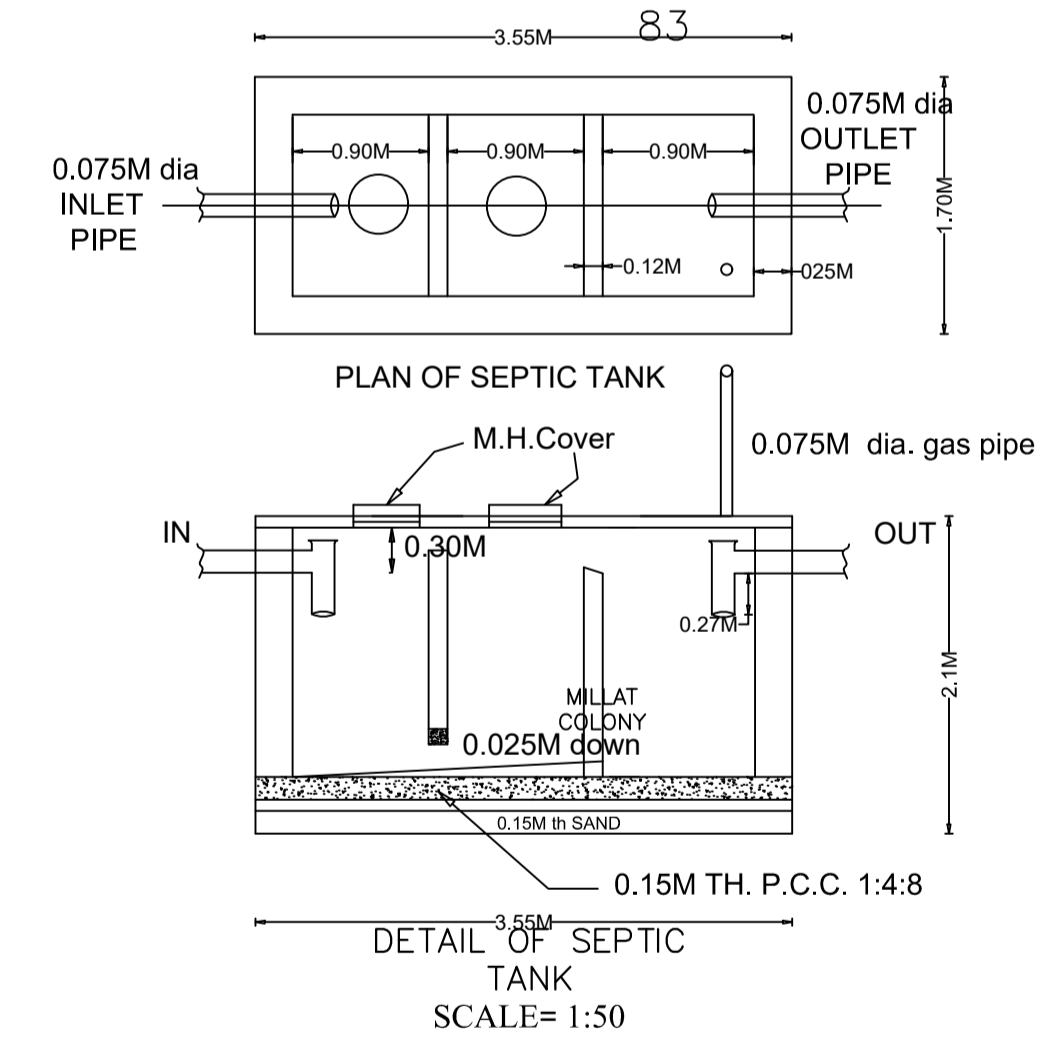
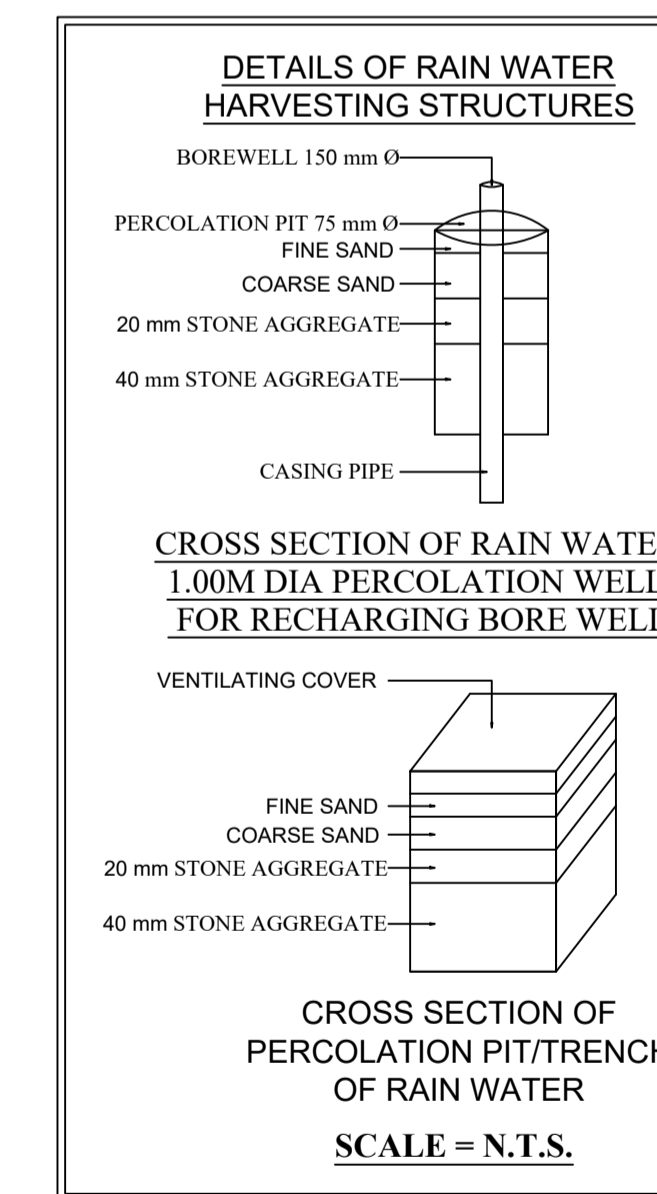

LTP NAME AND SIGNATURE	STRUCTURAL ENG'S NAME AND SIGNATURE	BUILDER NAME AND SIGNATURE	DIGITAL SIGNATURE
ABHISHEK TEWARI SNPC/ARC/0025/2021			

Proposal Basic Information	
Proposal File No.	SNPC/BP/0003/W04/2024
Owner Name	NIRANJAN KUMAR ADITYA AND JANMAJAY ADITYA
Khata No	62
Plot No	62
Village Name	Hansahudi
Use	Residential
SubUse	Bungalow/ Dwelling / Non Apartment

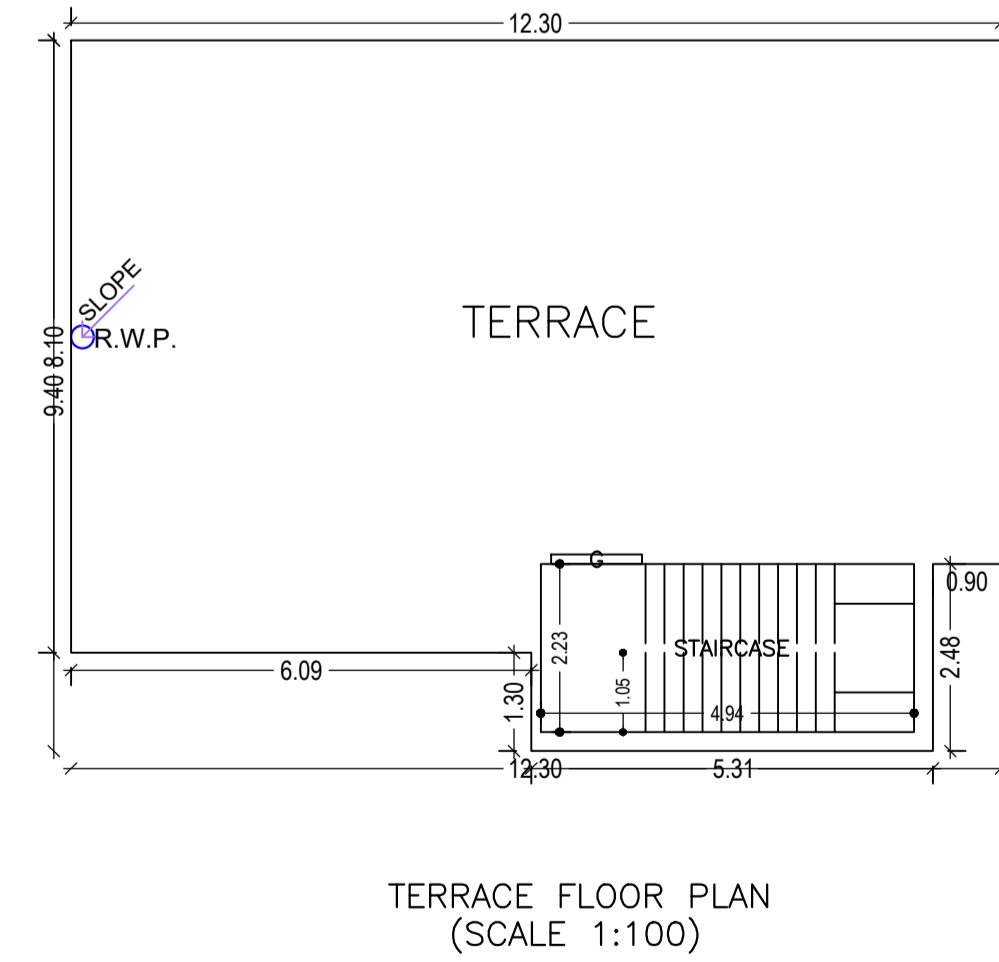
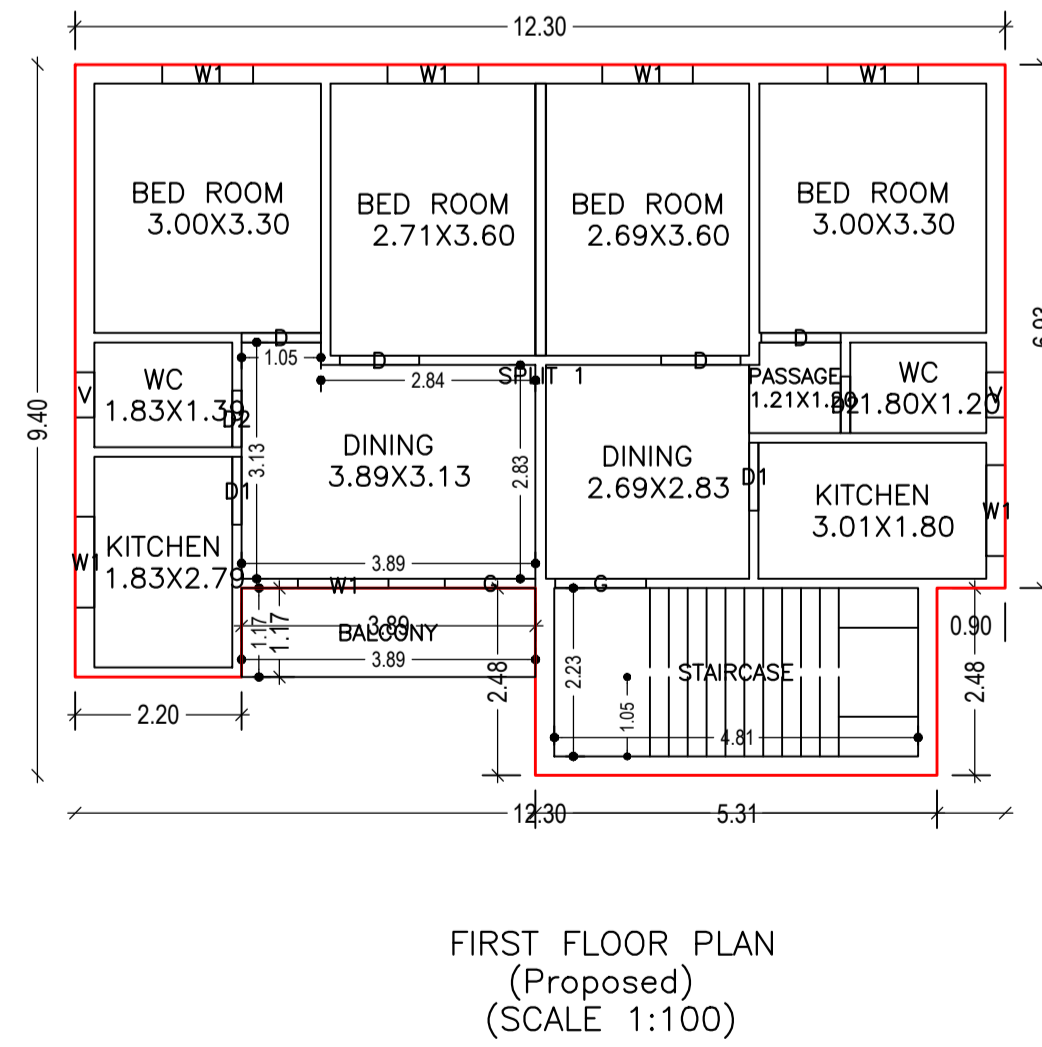
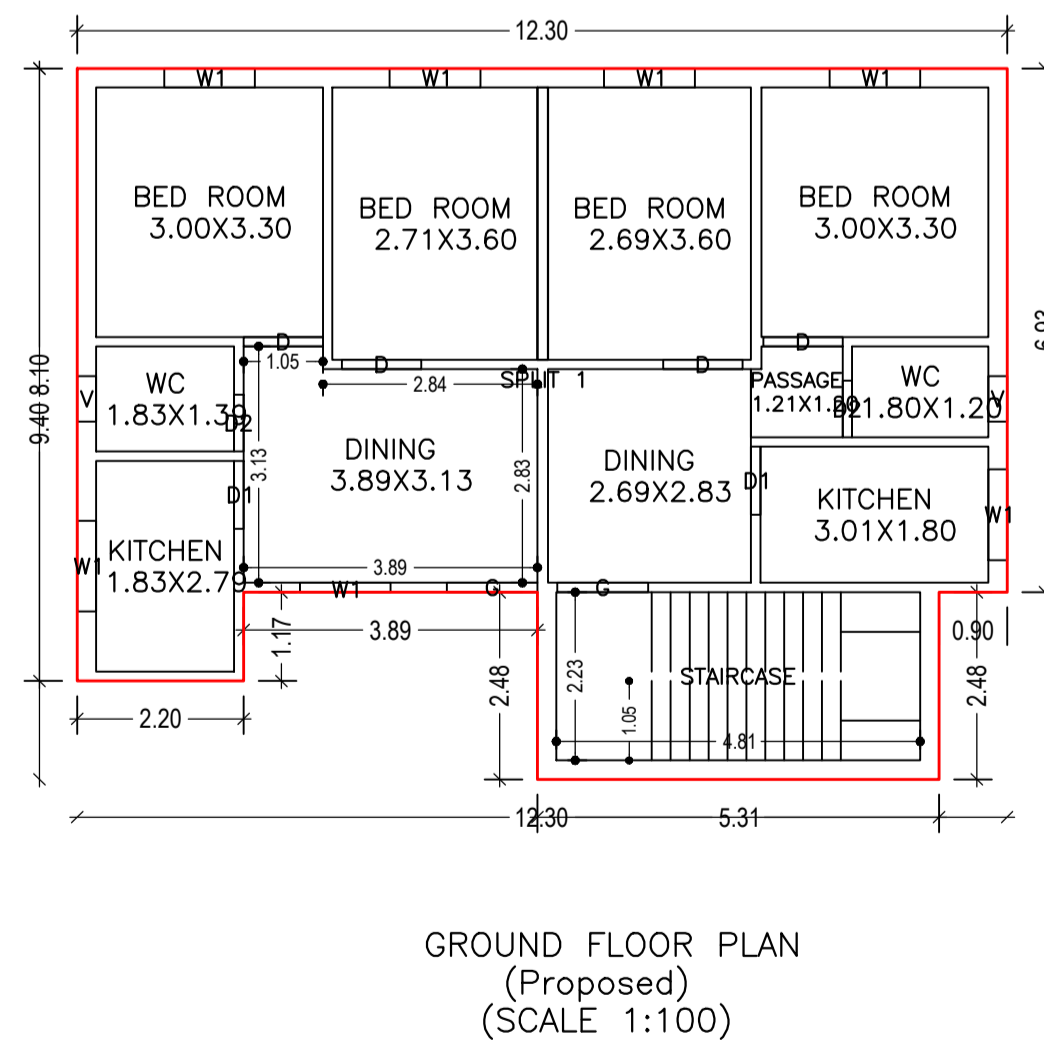
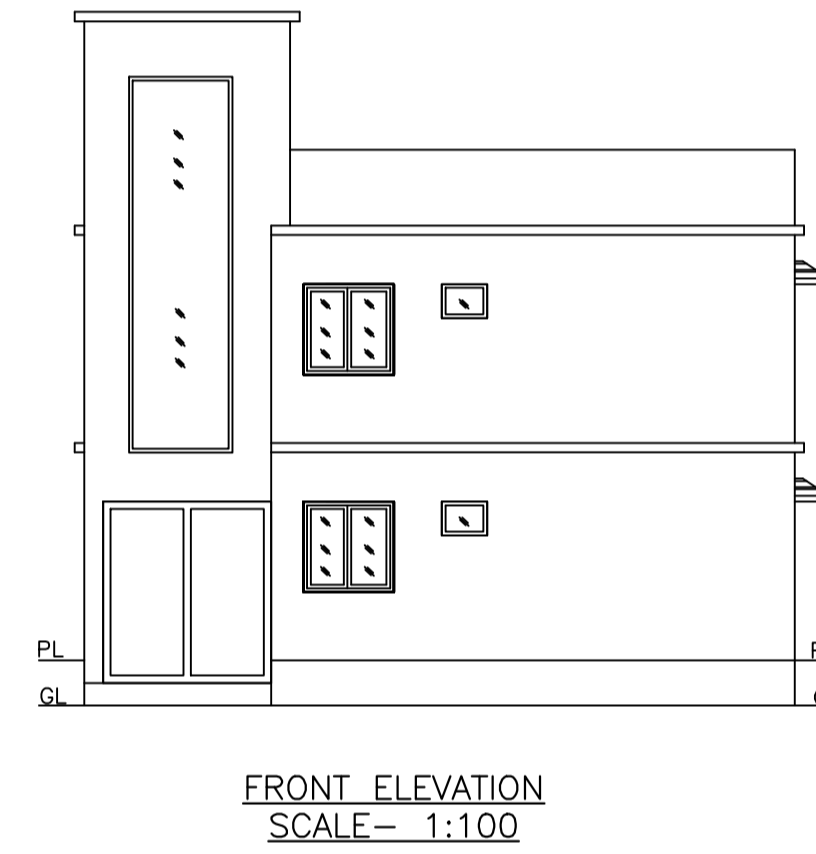
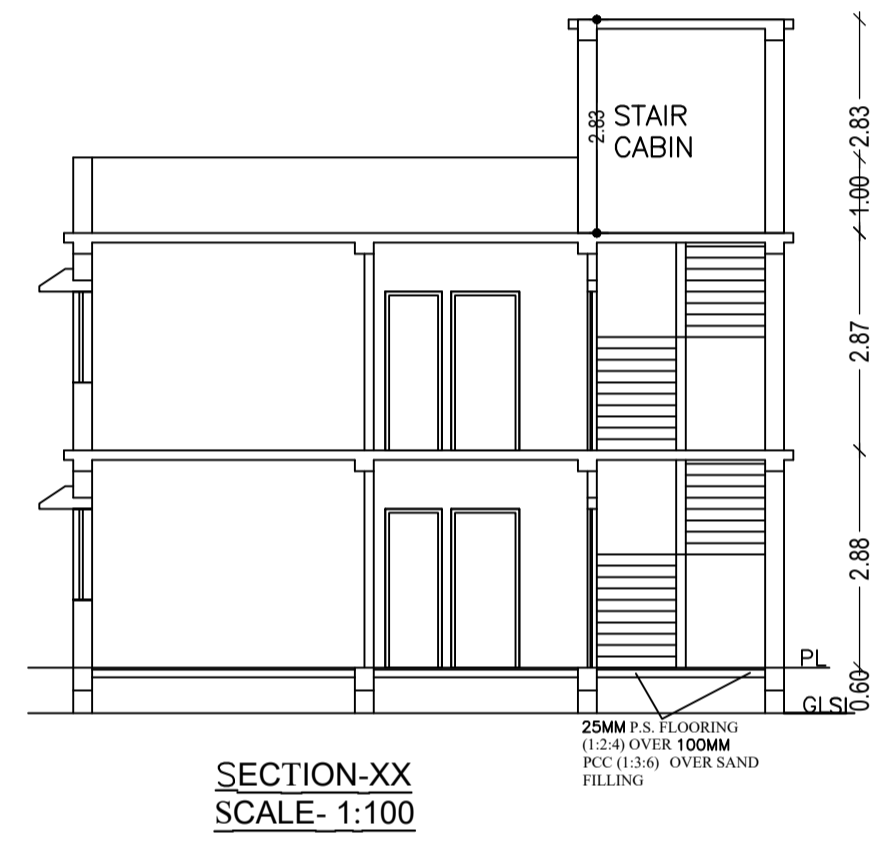
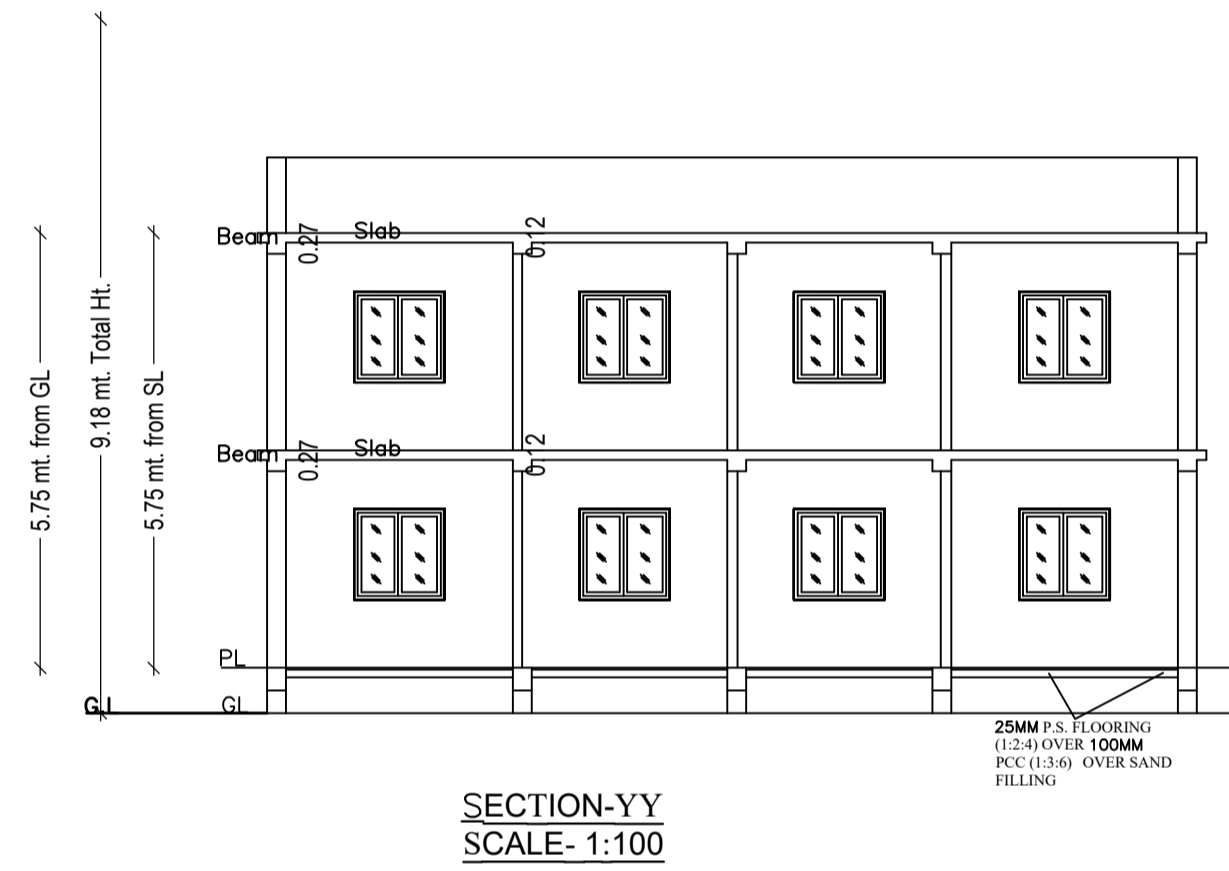
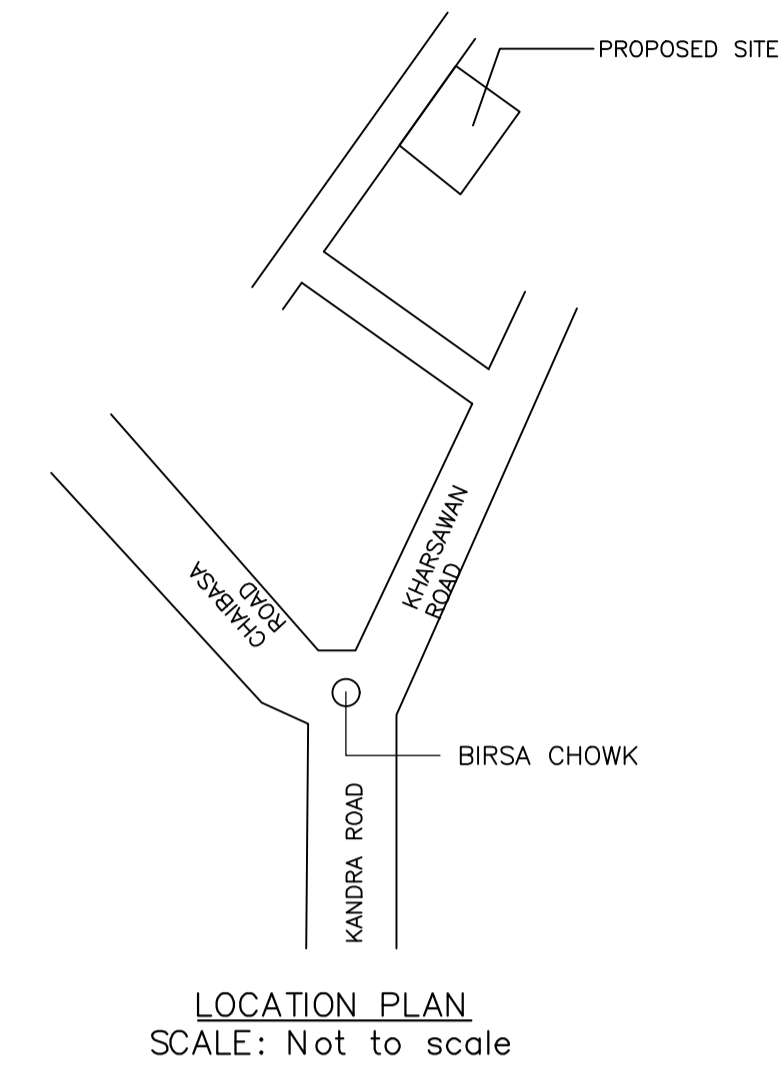

UnitBUA Table for Building :A (RESIDENTIAL)

FLOOR	Name	UnitBUA Type	UnitBUA Area	Carpet Area	No. of Rooms	No. of Tenement
GROUND FLOOR PLAN	SPLIT 1	FLAT	158.87	157.88	11	1
FIRST FLOOR PLAN	SPLIT 1	FLAT	0.00	0.00	11	0
Total:	-	-	158.87	157.88	22	1

LTP NAME AND SIGNATURE	STRUCTURAL ENG'S NAME AND SIGNATURE	BUILDER NAME AND SIGNATURE	DIGITAL SIGNATURE
ABHISHEK TEWARI SNPC/ARC/0025/2021			