

Project Title :PROPOSED RESIDENTIAL BUILDING MAP OF SMT.PRATIMA SAHU

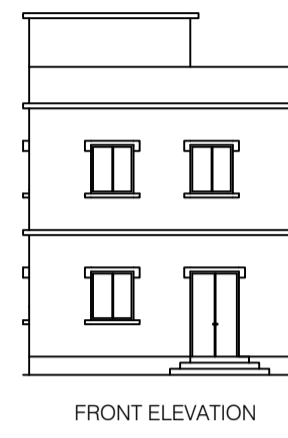

FRONT ELEVATION

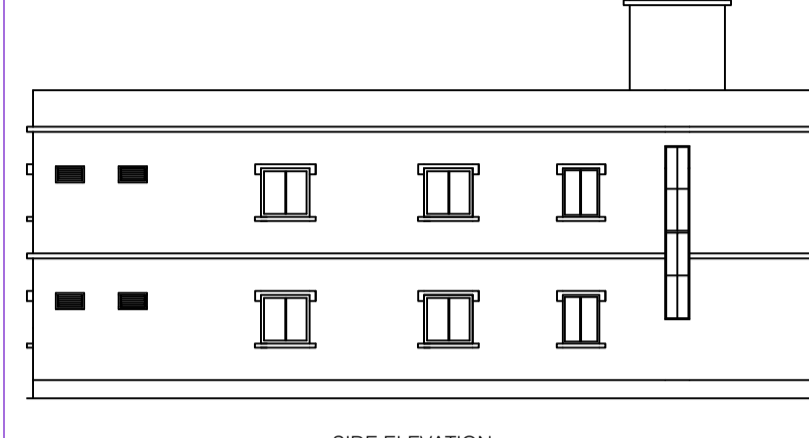

SIDE ELEVATION

Elevation 1 Detail

Elevation 2 Detail

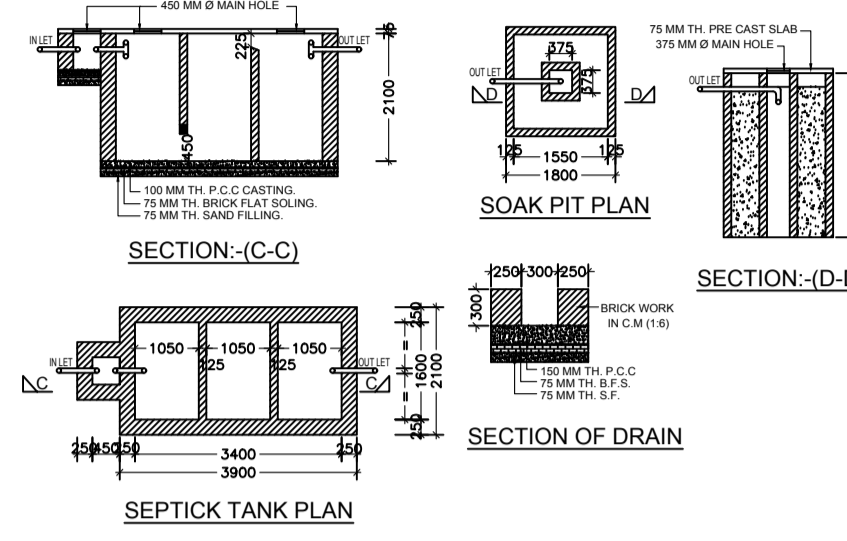

SEPTIC TANK PLAN

Soak Pit Detail

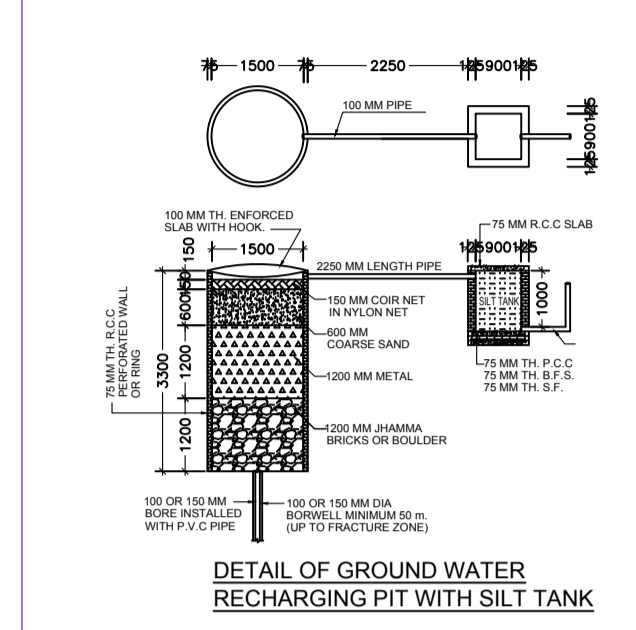

DETAIL OF GROUND WATER RECHARGING PIT WITH SILT TANK

Sub Water Storage Tank Detail

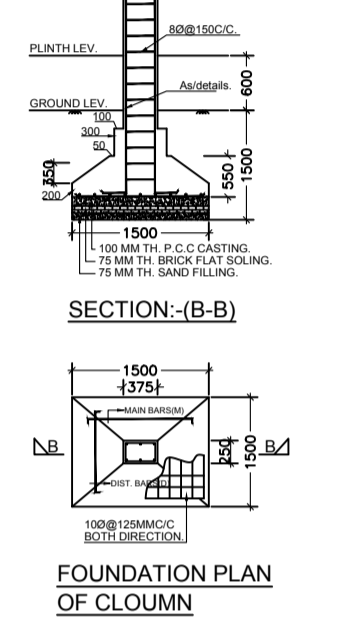

FOUNDATION PLAN OF COLUMN

Structure Detail

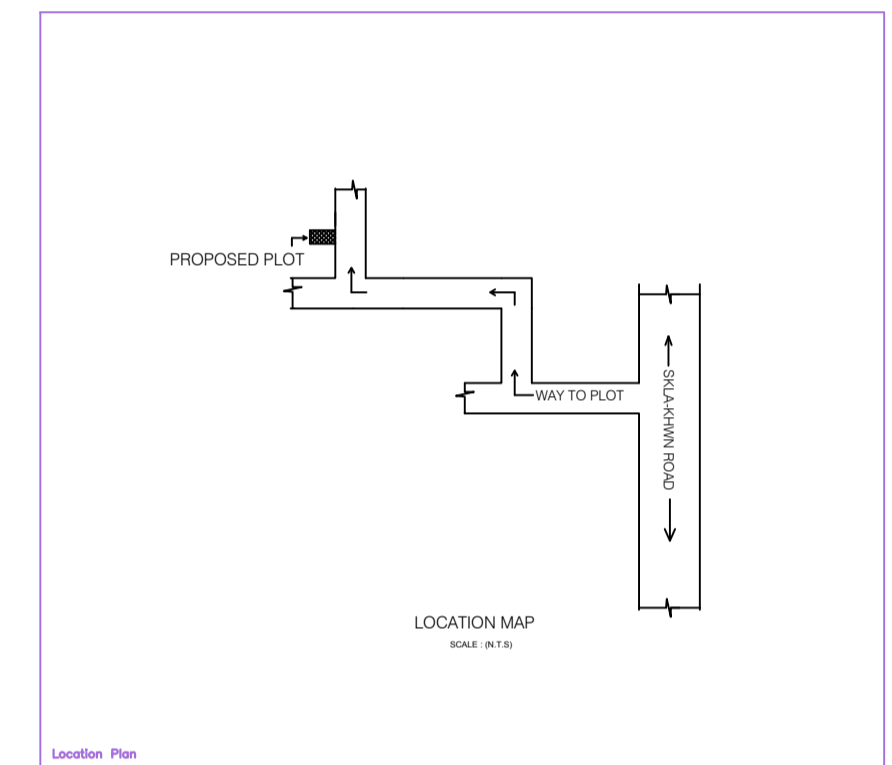

LOCATION MAP

Location Plan

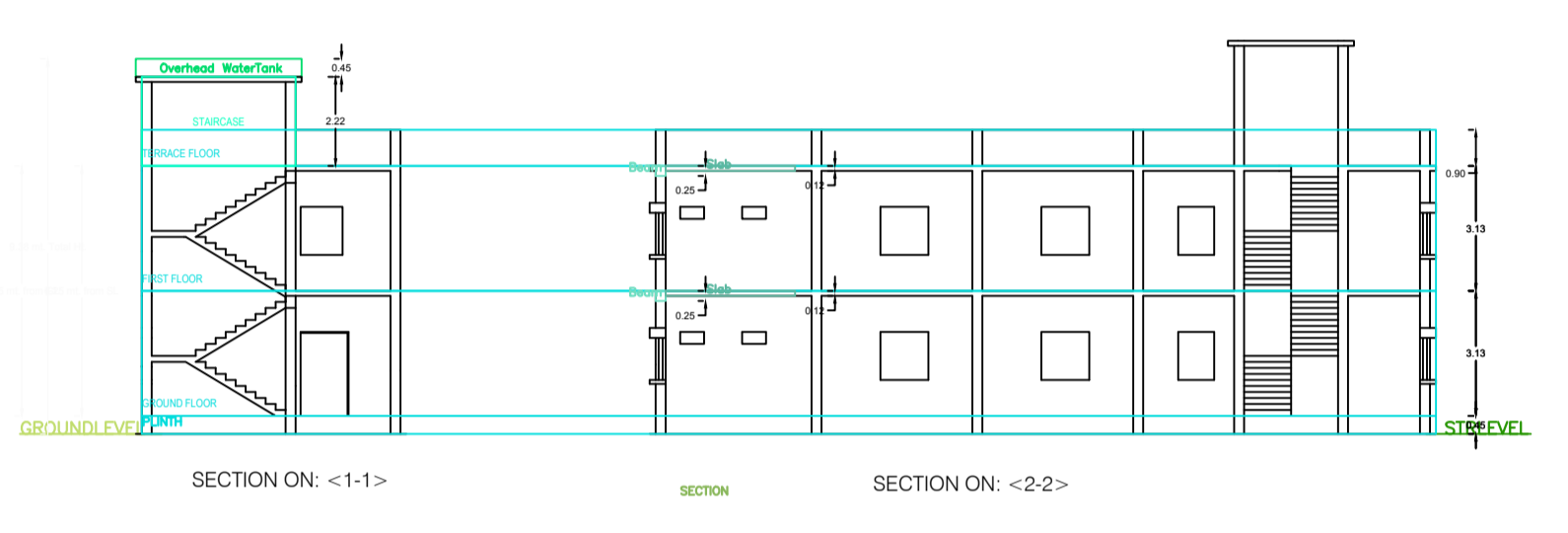

SECTION ON: <-1-1>

SECTION ON: <-2-2>

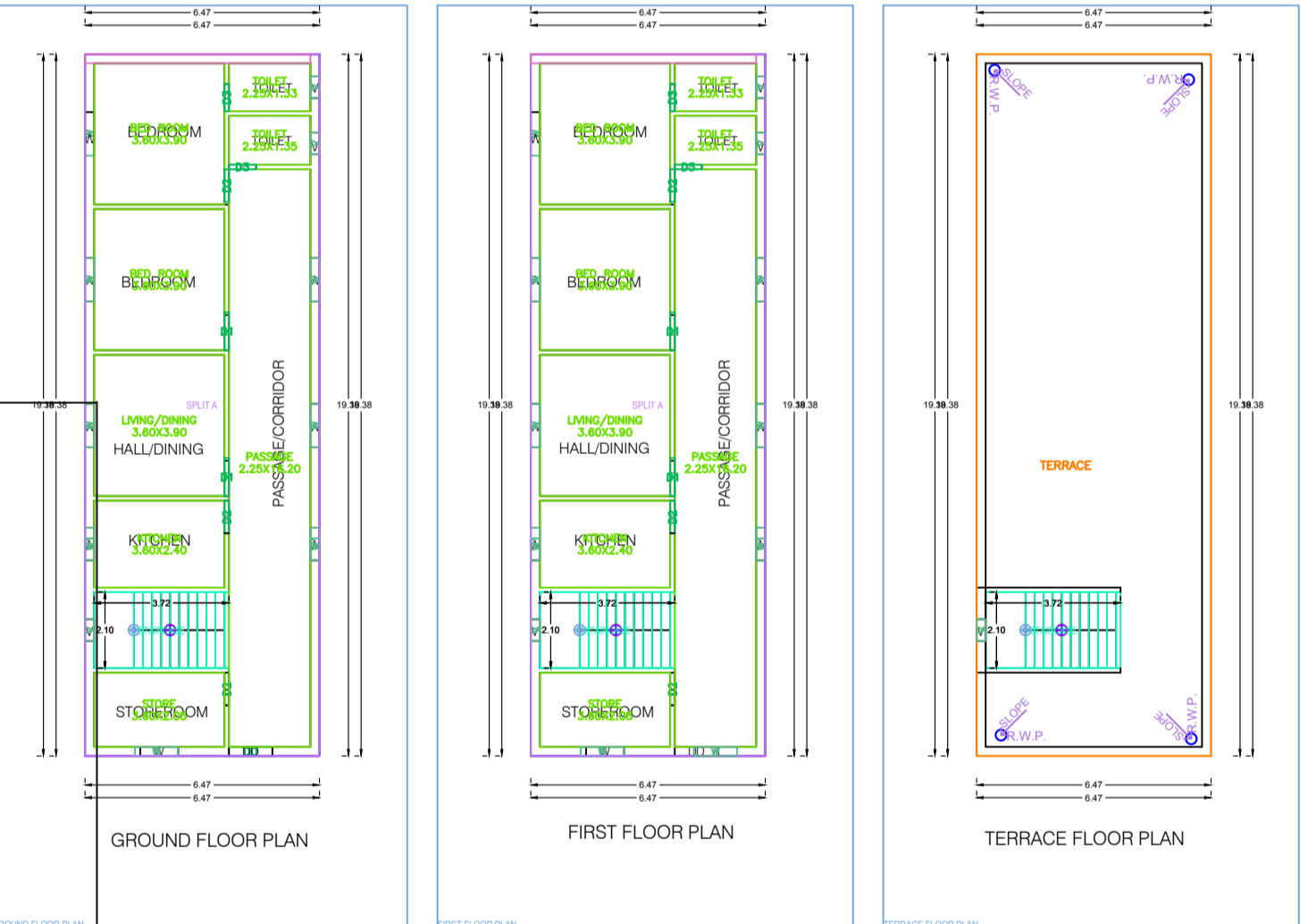

GROUND FLOOR PLAN

FIRST FLOOR PLAN

TERRACE FLOOR PLAN

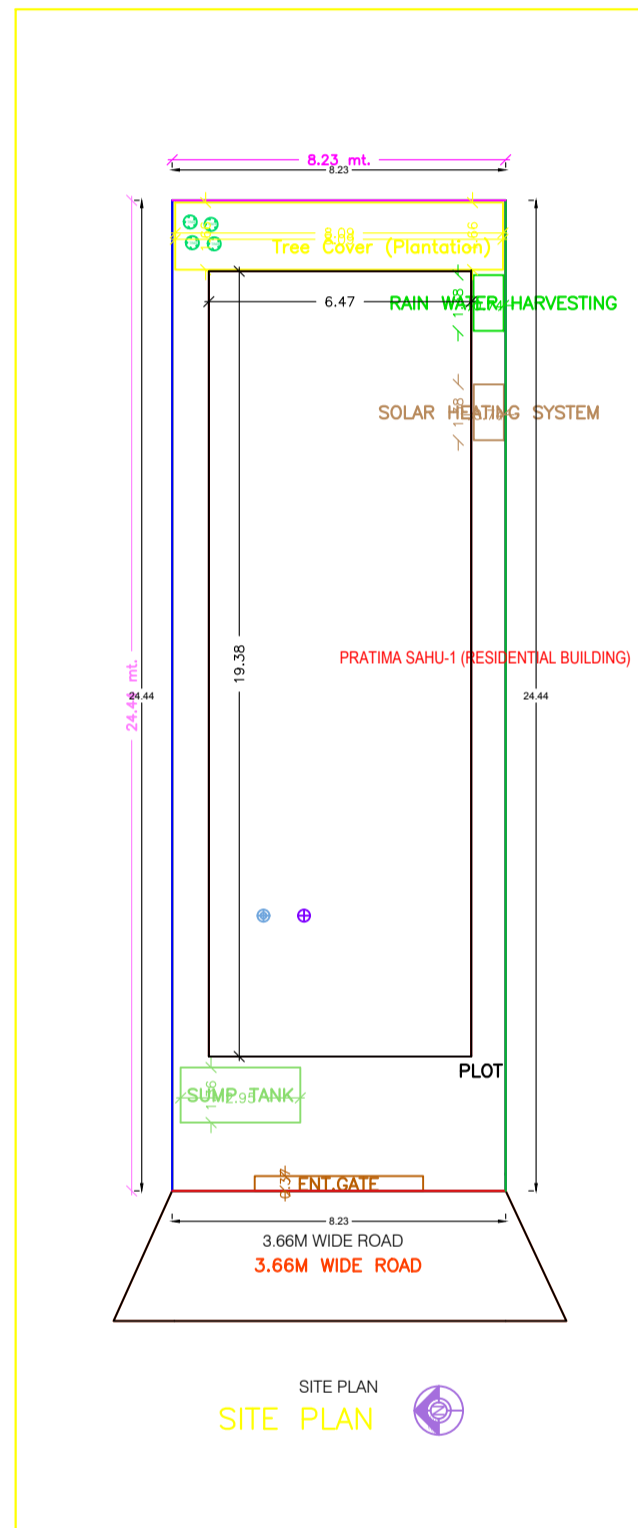

SITE PLAN

Building PRATIMA SAHU (RESIDENTIAL BUILDING)

Floor Name	Total Built Up Area (Sq.M)	Proposed FAR Area (Sq.M)	Total FAR Area (Sq.M)	Terr (No.)
Ground Floor	124.43	124.43	124.43	01
First Floor	124.43	124.43	248.86	02
Terrace Floor	0.00	0.00	248.86	01
Total	248.86	248.86	248.86	04

SCHEDULE OF JOINERY

ITEM	DESCRIPTION	NAME	LENGTH	HEIGHT	NO.
01	PRATIMA SAHU (RESIDENTIAL BUILDING)	DO	0.75	2.10	04
02	PRATIMA SAHU (RESIDENTIAL BUILDING)	DO	0.90	2.10	06
03	PRATIMA SAHU (RESIDENTIAL BUILDING)	DI	1.05	2.10	04
04	PRATIMA SAHU (RESIDENTIAL BUILDING)	DO	1.20	2.10	01
05	PRATIMA SAHU (RESIDENTIAL BUILDING)	DO	-	-	13

SCHEDULE OF JOINERY

ITEM	DESCRIPTION	NAME	LENGTH	HEIGHT	NO.
01	PRATIMA SAHU (RESIDENTIAL BUILDING)	V	0.60	1.00	07
02	PRATIMA SAHU (RESIDENTIAL BUILDING)	WI	0.90	1.20	04
03	PRATIMA SAHU (RESIDENTIAL BUILDING)	W	1.20	1.20	13
04	PRATIMA SAHU (RESIDENTIAL BUILDING)	DO	-	-	24

UnBIA Table for Building PRATIMA SAHU (RESIDENTIAL BUILDING)

FLOOR	Name	UNBIA Type	UNBIA Area	Colort Area	No. of Rooms	No. of Tenement
GROUND FLOOR PLAN	SPLIT A	FLAT	250.31	247.79	8	1
TERR	-	-	250.31	247.79	12	1

NO.	DESCRIPTION	UNIT	QUANTITY	REMARKS
1	Area of Plot	Sq. M	201.14	
2	Area of Building	Sq. M	248.86	
3	Area of Terrace	Sq. M	0.00	
4	Area of Road	Sq. M	13.30	
5	Area of Open Space	Sq. M	13.30	
6	Area of Green Space	Sq. M	13.30	
7	Area of Water Body	Sq. M	0.00	
8	Area of Other	Sq. M	0.00	
9	Total Area	Sq. M	291.14	
10	Area of Building	Sq. M	248.86	
11	Area of Terrace	Sq. M	0.00	
12	Area of Road	Sq. M	13.30	
13	Area of Open Space	Sq. M	13.30	
14	Area of Green Space	Sq. M	13.30	
15	Area of Water Body	Sq. M	0.00	
16	Area of Other	Sq. M	0.00	
17	Total Area	Sq. M	291.14	

Color Index

Color	Description
Red	Plot Boundary
Green	Proposed Open (Coverage Area)
Blue	Existing To be retained
Black	Existing To be removed

MARGIN DETAIL

Building Name	Road Name	Front Margin	Rear Margin	Side Margin	Set Back
PRATIMA SAHU (RESIDENTIAL BUILDING)	3.66M WIDE ROAD	3.32	1.75	0.91	0.85

FAR & Tenement Details (Table 4c-1)

Building	No. of Same Bldg	Total Built Up Area (Sq. M)	Proposed FAR Area (Sq. M)	Total FAR Area (Sq. M)	Terr (No.)
PRATIMA SAHU (RESIDENTIAL BUILDING)	1	250.30	250.30	250.30	01
Total	1	250.30	250.30	250.30	01