

Project Title :PROPOSED RESIDENTIAL BUILDING MAP OF BHAWANA DEVI

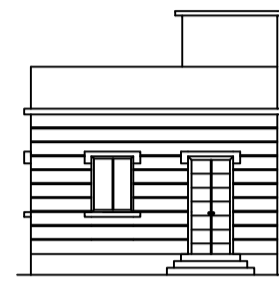

FRONT ELEVATION

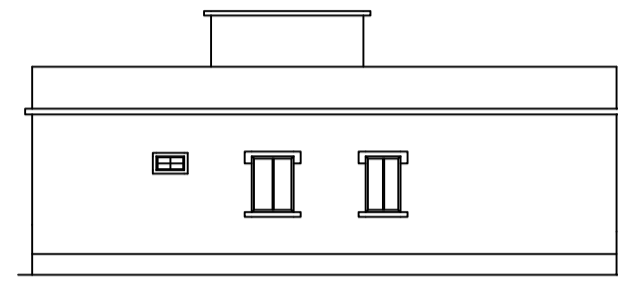

LEFT SIDE ELEVATION

Elevation 1 Detail

Elevation 2 Detail

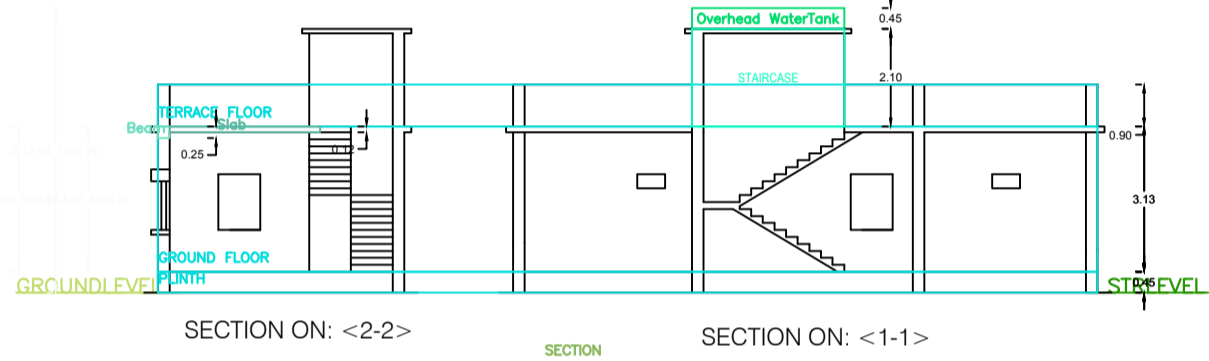

SECTION ON: <2-2>

SECTION ON: <1-1>

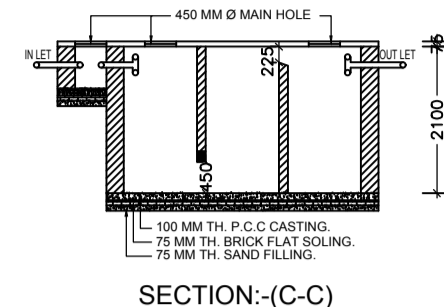

SECTION - (C-C)

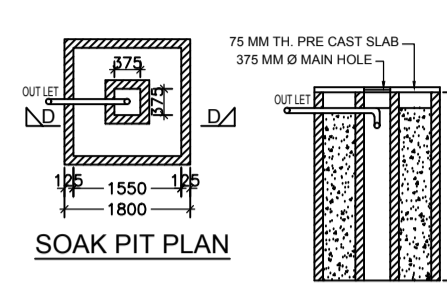

SOAK PIT PLAN

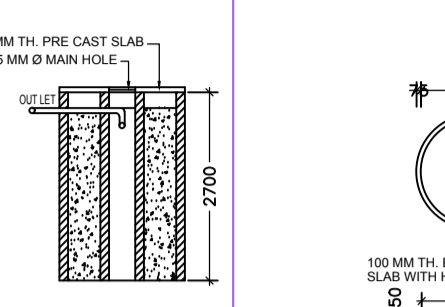

SECTION - (D-D)

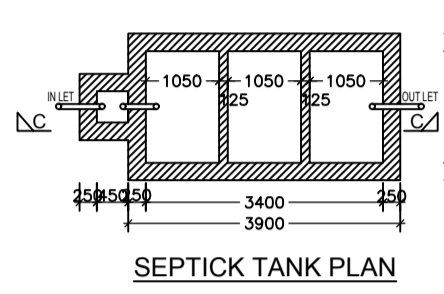

SEPTIC TANK PLAN

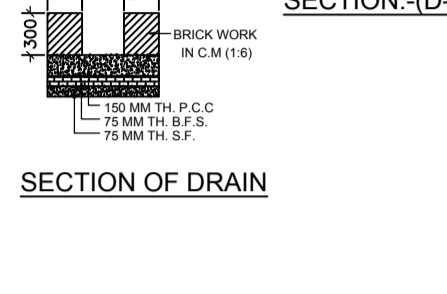

SECTION OF DRAIN

Septic Tank Detail

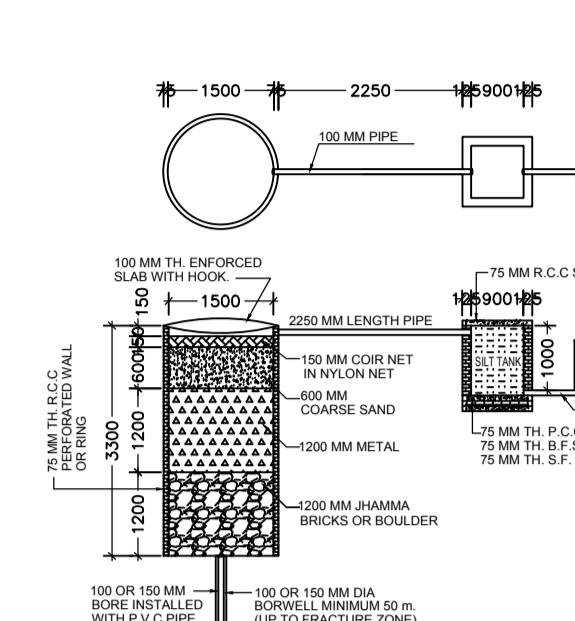

DETAIL OF GROUND WATER RECHARGING PIT WITH SILT TANK

Rain Water Storage Tank Detail

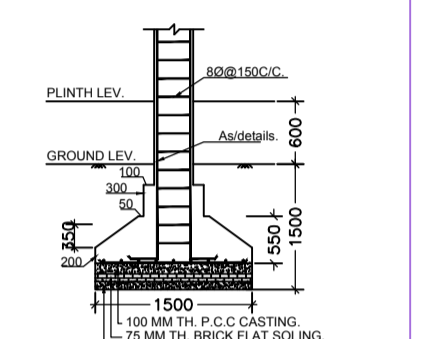

SECTION - (B-B)

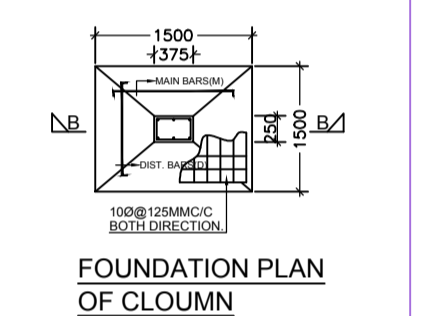

FOUNDATION PLAN OF COLUMN

Structure Detail

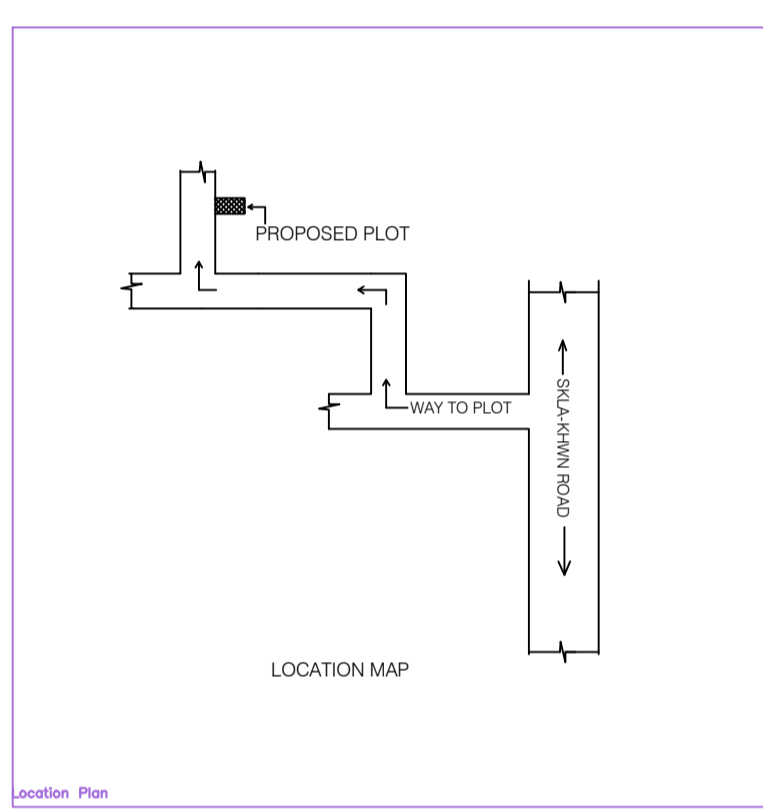

LOCATION MAP

Location Plan

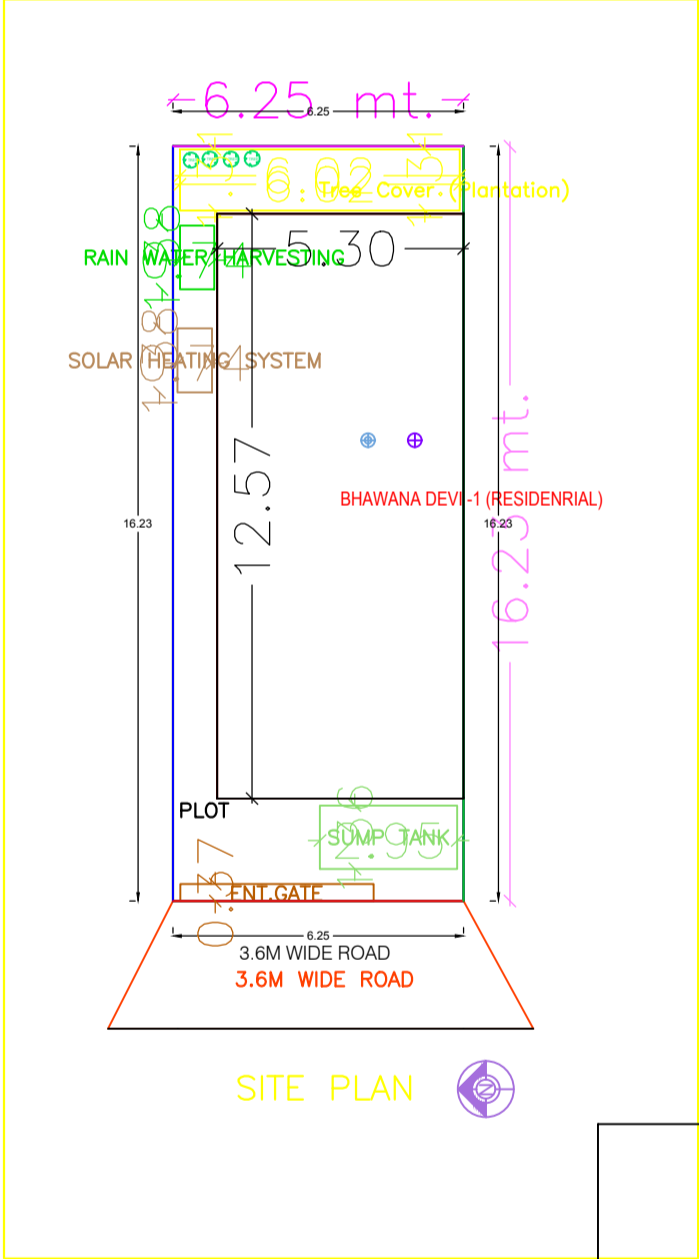

SITE PLAN

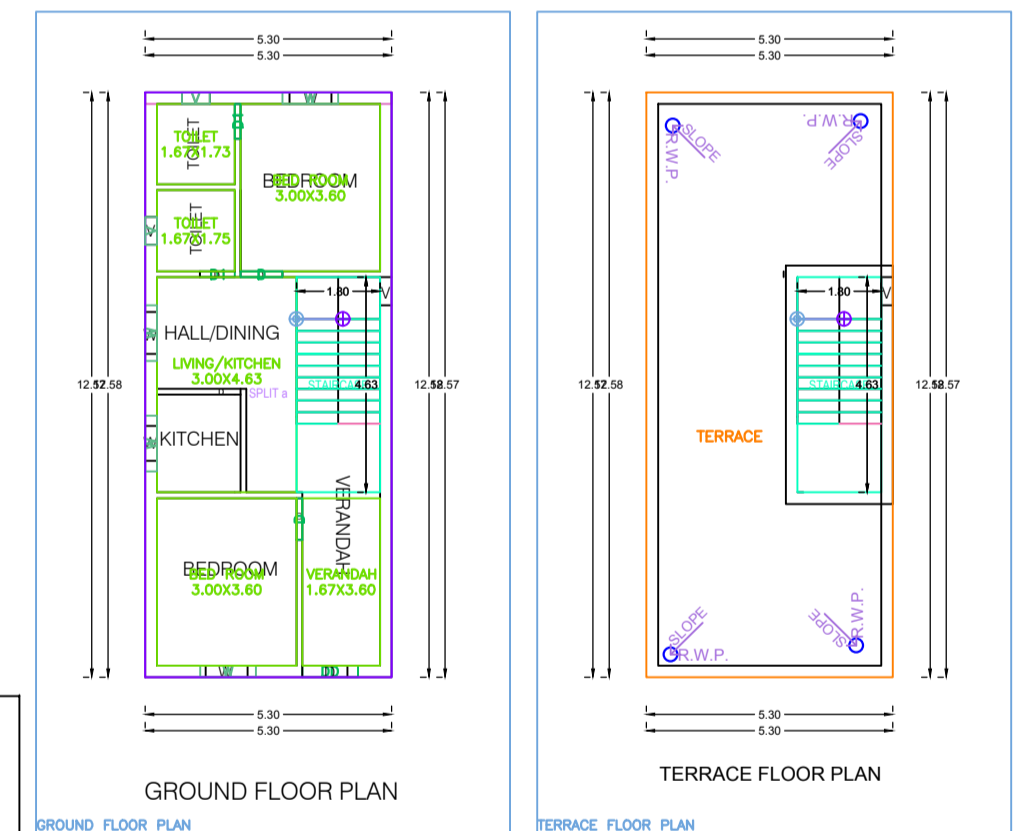

GROUND FLOOR PLAN

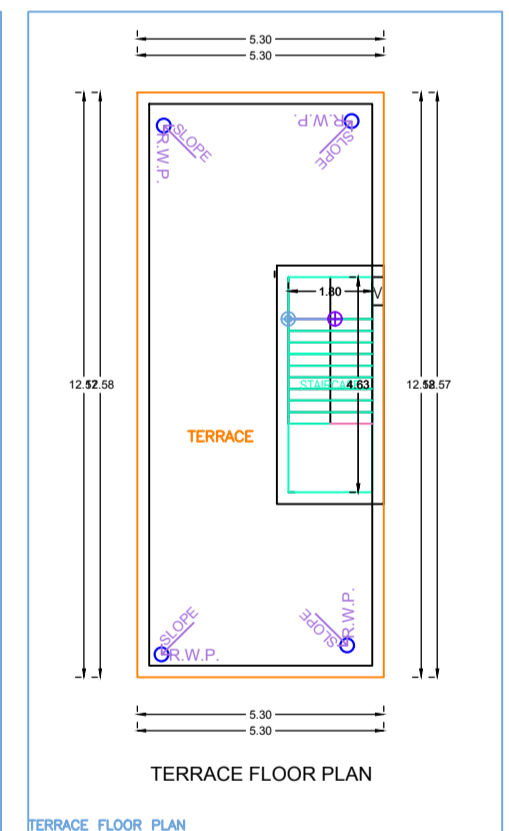

TERRACE FLOOR PLAN

Building BHAWANA DEVI (RESIDENTIAL)

Floor Name	Total Built Up Area (Sq.Mt.)	Proposed FAR Area (Sq.Mt.)	Total FAR Area (Sq.Mt.)	Trent (No.)
Ground Floor	66.65	66.65	66.65	01
Terrace Floor	0.00	0.00	0.00	00
Total	66.65	66.65	66.65	01
Total Number of Same Buildings	1	66.65	66.65	01
Total	66.65	66.65	66.65	01

SCHEDULE OF JOINERY:

BUILDING NAME	NAME	LENGTH	HEIGHT	NOS
BHAWANA DEVI (RESIDENTIAL)	D1	0.75	2.10	02
BHAWANA DEVI (RESIDENTIAL)	D	0.90	2.10	02
BHAWANA DEVI (RESIDENTIAL)	DD	1.20	2.10	01
Total	-	-	-	05

SCHEDULE OF JOINERY:

BUILDING NAME	NAME	LENGTH	HEIGHT	NOS
BHAWANA DEVI (RESIDENTIAL)	V	0.60	1.00	02
BHAWANA DEVI (RESIDENTIAL)	W	1.20	1.20	04
Total	-	-	-	06

UnitBUA Table for Building BHAWANA DEVI (RESIDENTIAL)

FLOOR	Name	UnitBUA Type	UnitBUA Area	Carpet Area	No. of Rooms	No. of Tenement
GROUND FLOOR PLAN	SPLIT #	FLAT	66.65	66.32	6	1
Total	-	-	66.65	66.32	6	1

AREA STATEMENT HAZARBASH NAGAR WARD

PROJECT DETAIL	VERSION NO. 1.0.37	VERSION DATE: 16/10/2020
Project No.:	Plot Use: Residential	
Region: BHAWANA URBAN LOCAL BODIES	Plot Location: Bungalow/Cowling / Non Apartment	
Project: BHAWANA DEVI	Local Use Zone: Residential	
Application Type: General Proposal	Abutting Road Width: -	
Project Name: Building Permission	Plot No.:	
Title of Developer: New	Reference Survey No/Survey No.:	
Location: Old Area	Thana No.:	
100 Location: NA	Ward No.:	
Village/Muza Name: -	Ward No.:	
Ward No.:	South: -	
East: -	West: -	
Area Details:		SQ.MT.
Area of Plot (Minimum)	(A)	121.44
Net POC Area (Gross POC Area - Deduction from Gross Plot Area)	(A) Deductions	121.44
COP Area		7.90
Total		7.90
Excess Plot Area (Net Plot Area - Recreational/Assembly space)	(A) Deductions	63.53
Plot Area for Coverage (Net Plot Area)	(A) Deductions	121.44
Plot Area for FSI (Net Plot Area + Road/Widening Area)		121.44
COVERAGE CHECK		
Proposed Coverage Area (65.70 %)		66.65
Total Coverage Area (65.70 %)		66.65
FAR CHECK		
Proposed Area of FAR		66.65
Total Area of FAR		66.65
REPLY OF PRELIMINARY CHECK		66.65
Total Proposed Built-up Area		66.65
ARCHITECT/SUPERVISOR (Stamp)	OWNER	
DEVELOPMENT AUTHORITY	LOCAL BODY	

COLOR INDEX

Color	Description
Green	Plot Boundary
Red	Abutting Road
Blue	Proposed Work (Coverage Area)
Yellow	Existing (To be retained)
White	Existing (To be demolished)

MARGIN DETAIL:

Building / Wing Name	Road Name	Front Margin	Rear Margin	Side Margin	Side2 Margin
BHAWANA DEVI (RESIDENTIAL)	3.6M WIDE ROAD	2.20	1.45	0.95	0.00

FAR & Tenement Details (Table 4c-1)

Building	No. of Same Bldg	Total Built Up Area (Sq.Mt.)	Proposed FAR Area (Sq.Mt.)	Total FAR Area (Sq.Mt.)	Trent (No.)
BHAWANA DEVI (RESIDENTIAL)	1	66.65	66.65	66.65	01
Grand Total	1	66.65	66.65	66.65	01