

CALCULATION FOR WATER TANK
CONSIDERING FOR 20 PERSONS = 20 X 135 = 2700 LTS.
[APROVIDED] = 5,000 LTS.

CALCULATION FOR SEPTIC TANK
CONSIDERING FOR 20 PERSONS = 20 X 0.083 = 1.66 CUM
[APROVIDED] = 2.78X1.06X1.5 = 4.4202 CUM

SCHEDULE OF AREA

PLOT AREA : 242.80 Sq.M

BUILT UP AREA OF GROUND FLOOR : 120.03 Sq.M

TOTAL BUILT UP AREA : 120.03 Sq.M

COVERED AREA : 120.03 Sq.M

OPEN SPACE AREA : 242.80-120.03 Sq.M = 122.77Sq.M

GROSS COVERED AREA : $\frac{120.03 \times 100}{242.80} = 49.43 \%$

F.A.R ACHIEVED : $\frac{120.03}{242.80} = 0.49$

SCHEDULE OF DOORS & WINDOWS :-

SL.NO.	MKD.	SIZE	DESCRIPTION
1.	D	1.07MX2.13M	Pannelled single shutter door.
2.	D1	0.91MX2.13M	Pannelled single shutter door.
3.	D2	0.76MX2.13M	Pannelled single shutter door.
4.	W	1.52MX1.22M	Glazed steel framed window 3. shutt.
5.	W1	1.22MX1.22M	Glazed steel framed window 3. shutt.
6.	W2	0.91MX1.22M	Glazed steel framed window 3. shutt.
7.	V	0.61MX0.61M	Top hung steel ventilator.

PROPOSED RESIDENTIAL BUILDING FOR
MR. TARAK NATH MUKHI
S/O KARTIKESHWAR MUKHI
AT WARD NO : 04 (OLD 01)
AT VILLAGE : HENSAHUDI
HOLDING NO : 0040000706000M0
KHATA NO : 198, PLOT NO : 117/A
RAKWA : 6 Decr , MOUJA - SERAIKELLA
THANA : SERAIKELLA , THANA NO :301
DISTRICT : SERAIKELLA-KHARSAWAN,
JHARKHAND

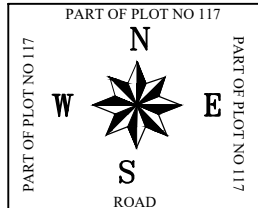
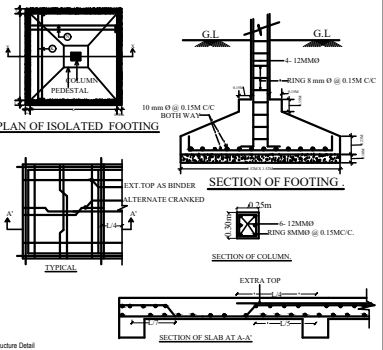
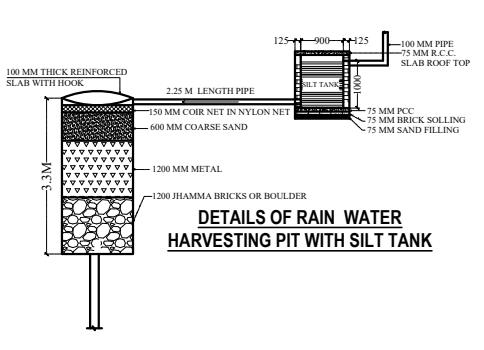
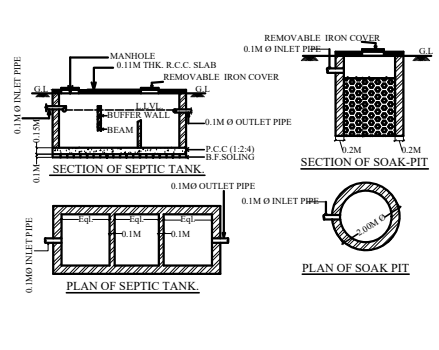

SCALE : 1:100

AS MENTIONED IN DRAWINGS

SIGNATURE OF OWNER	SIGNATURE OF REGISTERED CONSULTANT SNP SERAIKELLA
SIGNATURE OF ENGINEER SNP SERAIKELLA	SIGNATURE OF EXECUTIVE OFFICER SNP SERAIKELLA