

Proposal Basic Information

Proposal File No.	KONPC/BP/0015/W02/2018
Owner Name	SMT REKHA KUMARI ALIAS GIRJA DEVI
Khata No	475
Plot No	650 (P)
Village Name	Kodarma
Use	Residential
SubUse	Residential Bldg/Apartment

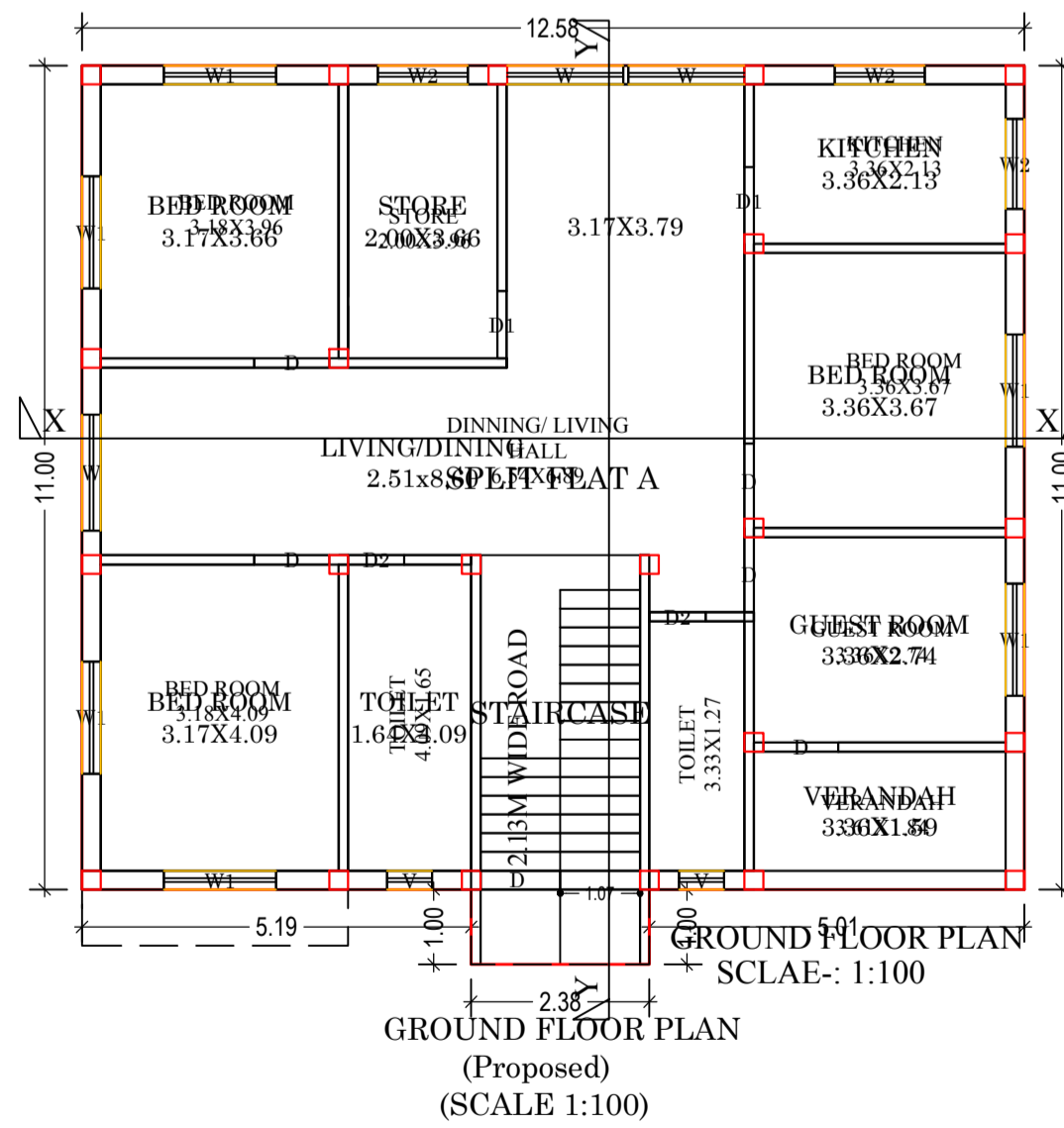
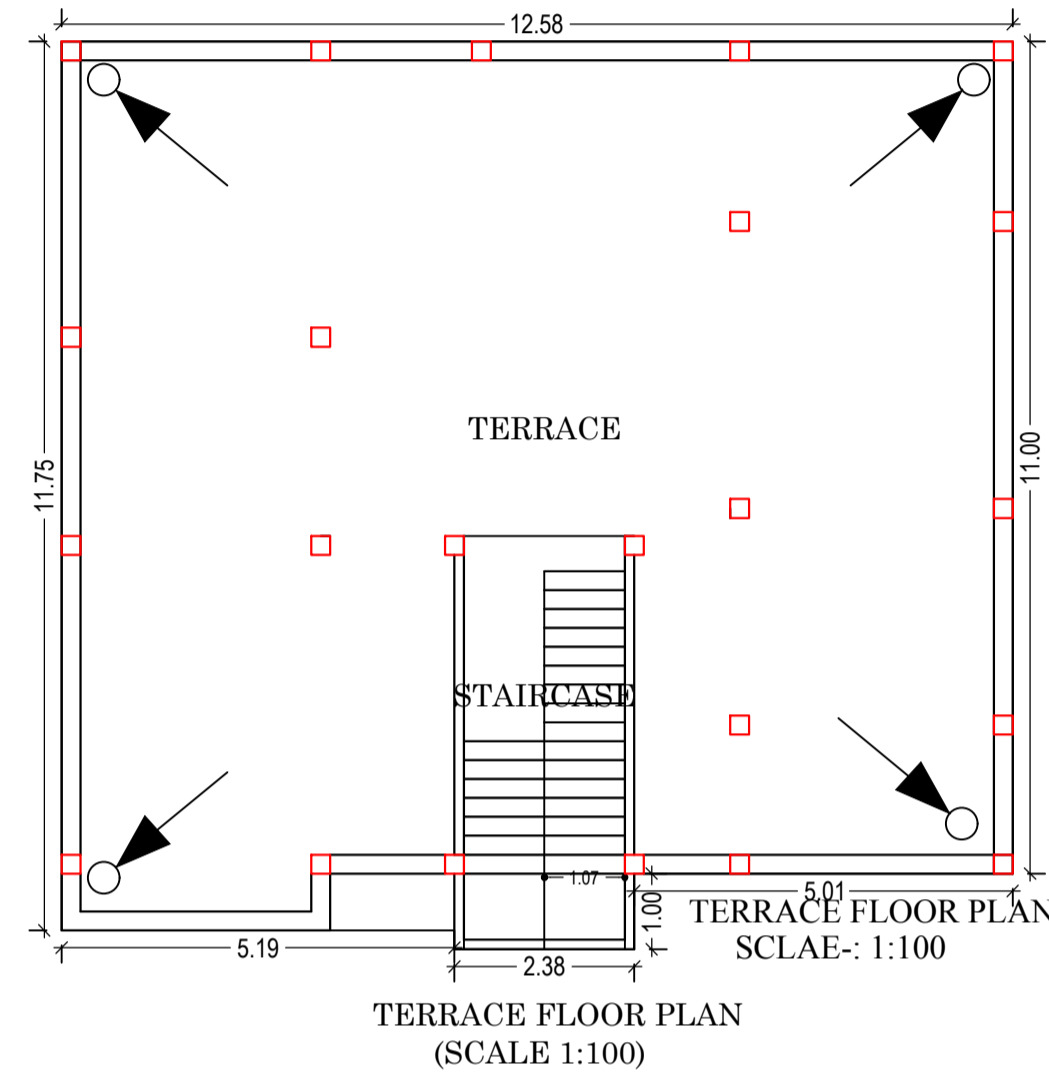
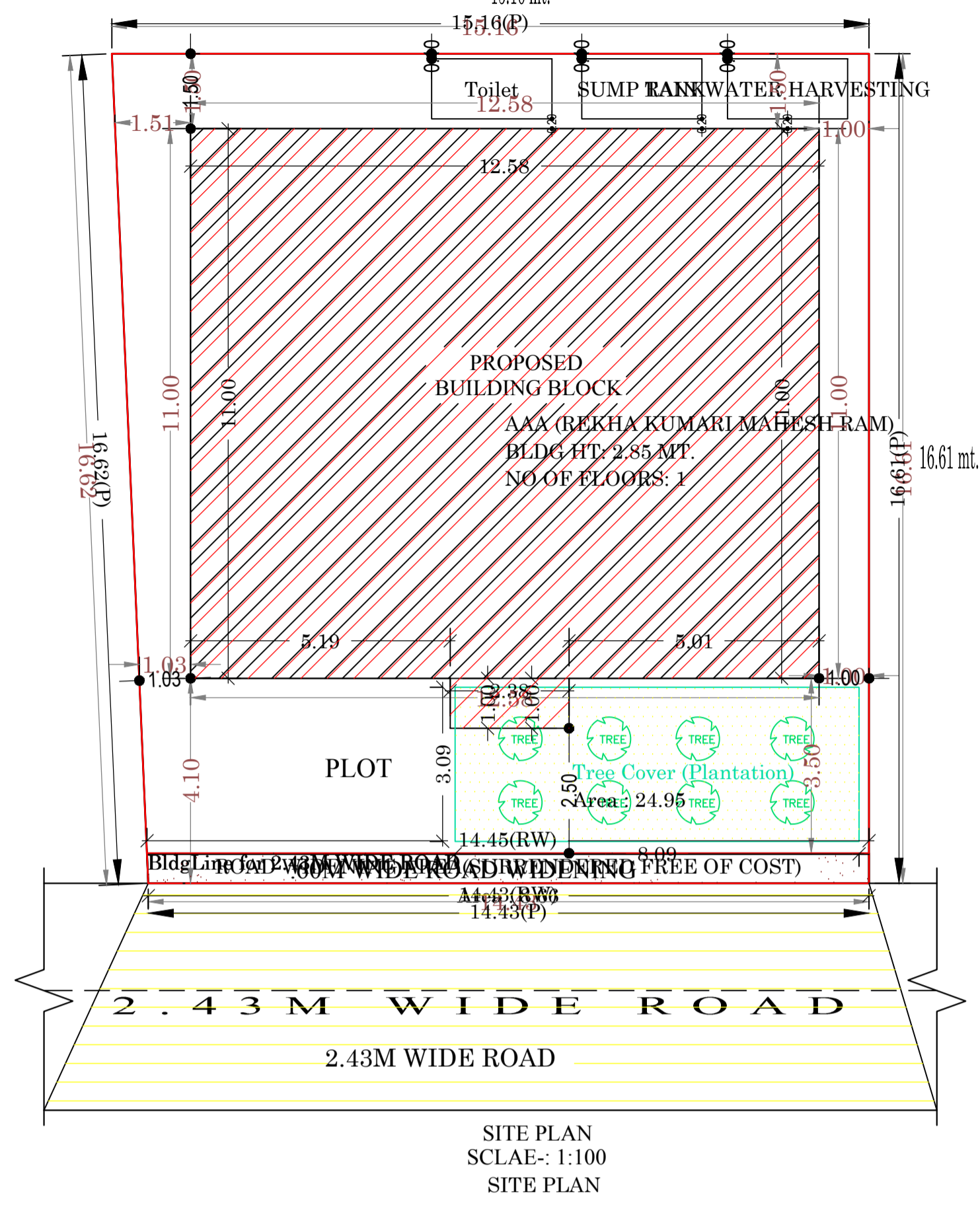

AREA STATEMENT KODERMA NAGAR PANCHAYAT	VERSION NO.: 1.0.29 VERSION DATE: 30/06/2018
PROJECT DETAIL:	
Region: JHARKHAND URBAN	Plot Use: Residential
LOCAL BODIES	Plot SubUse: Residential Bldg/Apartment
District: KODERMA	PlotNearbyReligiousStructure: NA
Authority: KODERMA NAGAR PANCHAYAT	Plot/SubPlot No: 650 (P)
Inward_No: KONPC/BP/0015/W02/2018	North: Plot No. - PLOT NO 646
Application Type: General Proposal	South: Plot No. - SMT KAMLA DEVI W/O SHAILENDRA KUMAR
Project Type: Building Permission	East: Plot No. - NAM MIYAN
Nature of Development: New	West: Road Width - 2.43M WIDE ROAD
Location of Development Area: Old Area	
AREA DETAILS:	
AREA OF PLOT (Minimum)	(A) 245.65
Deduction for NetPlot Area	
Surrender Free of Cost	8.66
Total	8.66
NET AREA OF PLOT/Gross Plot Area	
- Deduction from Gross Plot area)	(A-Deductions) 236.99
Deduction for Balance Plot Area(from Gross Plot Area)	
Surrender Free of Cost	8.66
Common Plot	24.95
Total	33.62
BALANCE AREA OF PLOT(Net Plot Area - Recreational/Amenity space)	(A-Deductions) 212.03
PLOT AREA FOR COVERAGE(Net Plot Area)	(A-Deductions) 236.99
Plot Area for FAR (Net Plot Area + RoadWidening Area)	(A-Deductions) 245.65
COVERAGE CHECK	
Permissible Coverage area ( 60.00 % )	142.19
Proposed Coverage Area ( 59.42 % )	140.81
Total Prop. Coverage Area ( 59.42 % )	140.81
Balance coverage area ( 0.58 % )	1.38
FAR CHECK	
Perm. FAR Area ( 1.20 )	294.78
Total Perm. FAR area	294.78
Residential FAR	140.81
Proposed FAR Area	140.81
Total Proposed FAR Area	140.81
Consumed FAR (Factor)	0.57
Balance FAR Area	153.97
BUILT UP AREA CHECK	
Total Proposed BuiltUp Area	140.81
ARCHITECT (Regd)	MD SHOAB ALAM
ENGINEER (Regd)	
SUPERVISOR (Regd)	
OWNER (Regd)	SMT REKHA KUMARI ALIAS GIRJA DEVI
DEVELOPMENT AUTHORITY	LOCAL BODY

SCHEDULE OF DOOR:

BUILDING NAME	NAME	LENGTH	HEIGHT	NOS
AAA (REKHA KUMARI MAHESH RAM)	D2	0.75	2.13	01
AAA (REKHA KUMARI MAHESH RAM)	D1	0.90	2.10	02
AAA (REKHA KUMARI MAHESH RAM)	D	1.00	2.10	05

SCHEDULE OF WINDOW/VENTILATION:

BUILDING NAME	NAME	LENGTH	HEIGHT	NOS
AAA (REKHA KUMARI MAHESH RAM)	V	0.60	0.60	01
AAA (REKHA KUMARI MAHESH RAM)	W2	1.20	1.20	03
AAA (REKHA KUMARI MAHESH RAM)	W1	1.50	1.20	06
AAA (REKHA KUMARI MAHESH RAM)	W	1.55	1.20	03

UnitBUA Table for Building :AAA (REKHA KUMARI MAHESH RAM)

FLOOR	Name	UnitBUA Type	UnitBUA Area	Carpet Area	No. of Rooms	No. of Tenement
GROUND FLOOR PLAN	SPLIT FLAT A	FLAT	116.86	111.39	9	1
Total			116.86	111.39	9	1

Building USE/SUBUSE Details

Building Name	Building Use	Building SubUse	Building Structure
AAA (REKHA KUMARI MAHESH RAM)	Residential	Residential Bldg/Apartment	Non-Highrise

Building :AAA (REKHA KUMARI MAHESH RAM)

Floor Name	Total Built Up Area (Sq.mt.)	Proposed FAR Area (Sq.mt.) Resi.	Total FAR Area (Sq.mt.)	Total Consumed Additional FAR Area (Sq.mt.)	Tnmt (No.)
Ground Floor	140.81	140.81	140.81	140.81	01
Terrace Floor	0.00	0.00	0.00	0.00	00
Total :	140.81	140.81	140.81	140.81	01
Total Number of Same Buildings	1				
Total :	140.81	140.81	140.81	140.81	01

FAR & Tenement Details (Table 4c-1)

Building	No. of Same Bldg	Total Built Up Area (Sq.mt.)	Proposed FAR Area (Sq.mt.) Resi.	Total FAR Area (Sq.mt.)	Total Consumed Additional FAR Area (Sq.mt.)	Tnmt (No.)
AAA (REKHA KUMARI MAHESH RAM)	1	140.81	140.81	140.81	140.81	01
Grand Total :	1	140.81	140.81	140.81	140.81	01

Buildingwise Floor FAR Details

Floor Name	Building Name		Total	
	AAA (REKHA KUMARI MAHESH RAM)	Proposed FAR Area (Sq.mt.)	Total Proposed Built Up Area (Sq.mt.)	Total FAR Area (Sq.mt.)
Ground Floor	140.81	140.81	140.81	140.81
Terrace Floor	0.00	0.00	0.00	0.00
Total :	140.81	140.81	140.81	140.81

COLOR INDEX

Color	Description
Black	PLOT BOUNDARY
Red	ABUTTING ROAD
Green	PROPOSED CONSTRUCTION
Yellow	COMMON PLOT
Blue	ROAD WIDENING AREA
White	EXISTING (To be retained)
Grey	EXISTING (To be demolished)

LTP NAME AND SIGNATURE STRUCTURAL ENG'S NAME AND SIGNATURE BUILDER NAME AND SIGNATURE

MD SHOAB ALAM KONPC/ENG/0004/2017		
--------------------------------------	--	--

Proposal Basic Information

Proposal File No.	KONPC/BP/0015/W02/2018
Owner Name	SMT REKHA KUMARI ALIAS GIRJA DEVI
Khata No	475
Plot No	650 (P)
Village Name	Koderma
Use	Residential
SubUse	Residential Bldg/Apartment

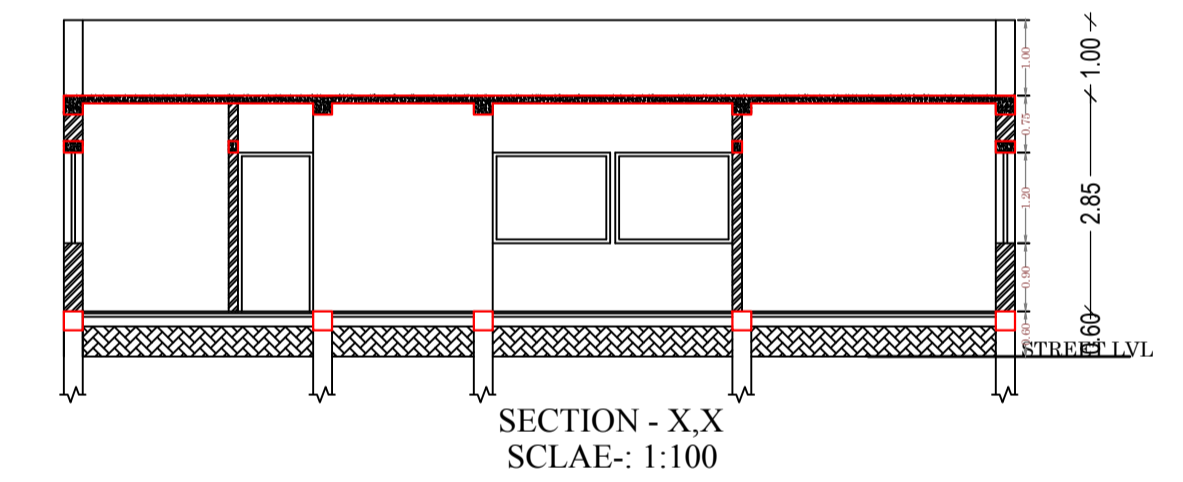
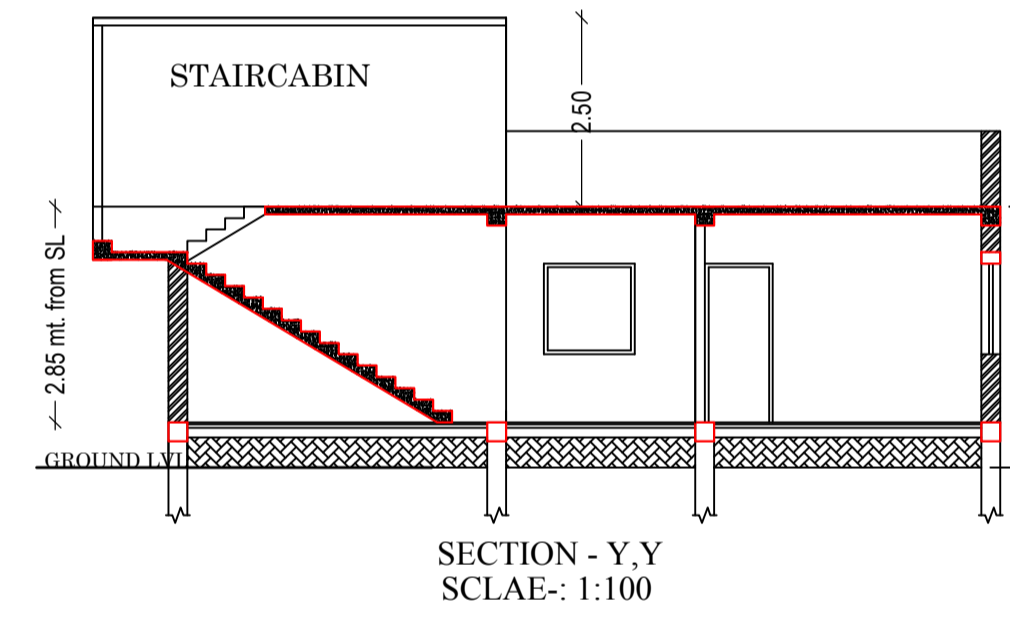
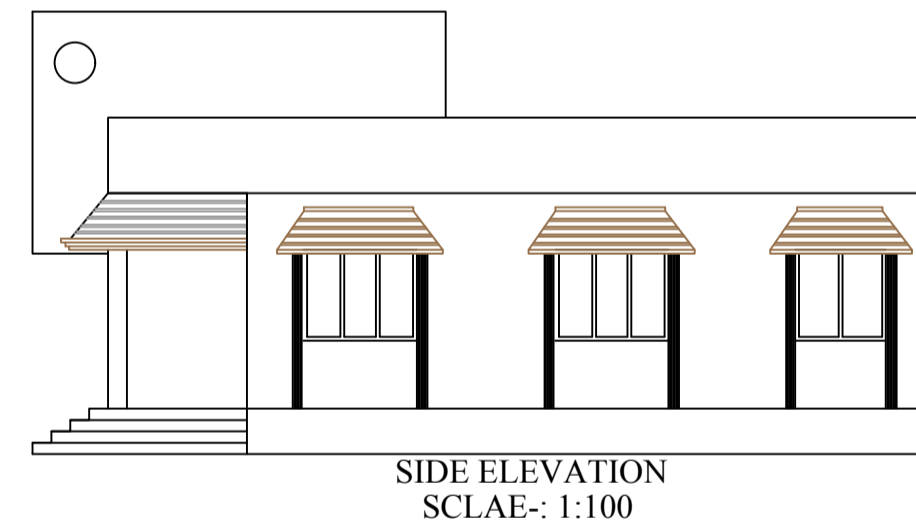
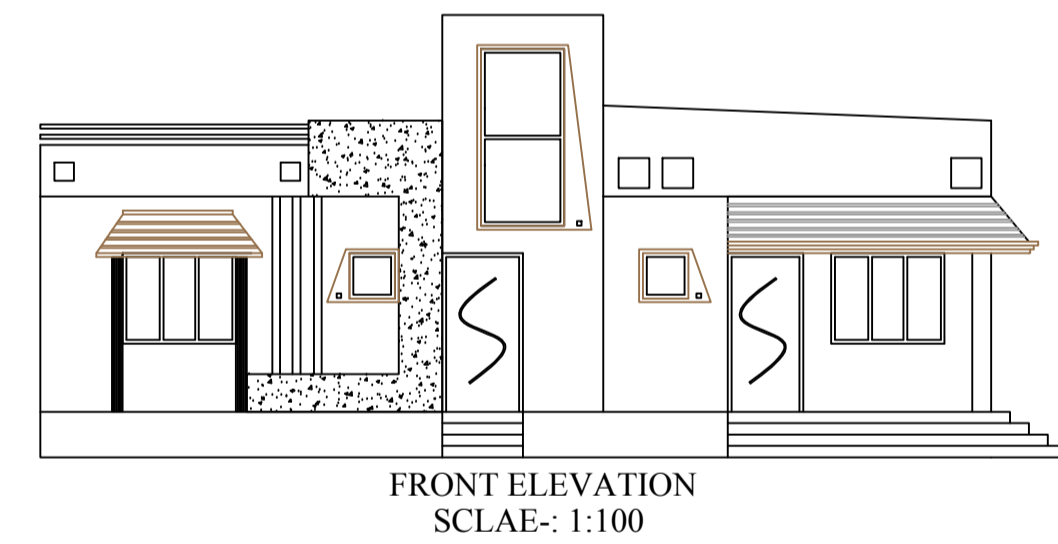
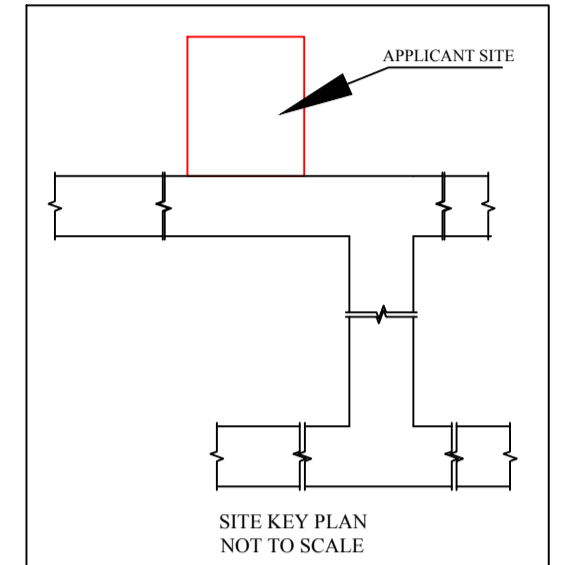
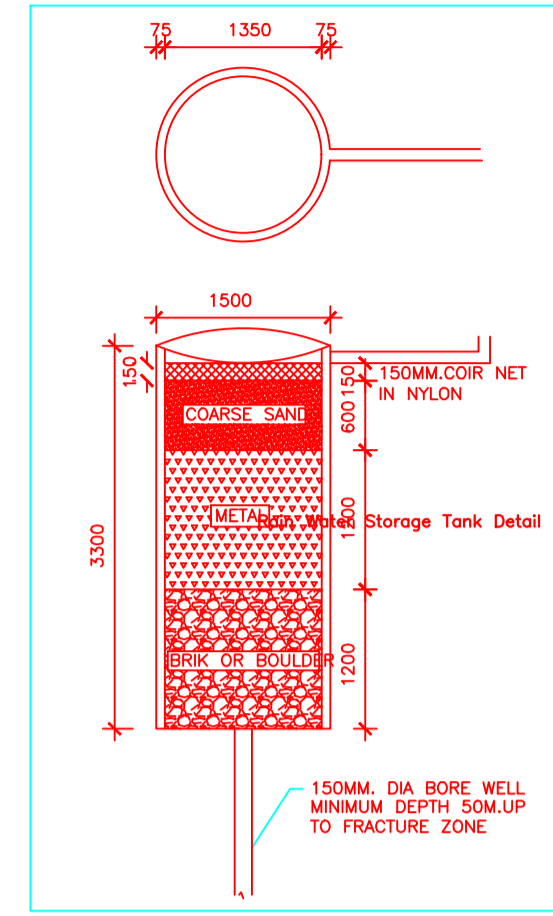
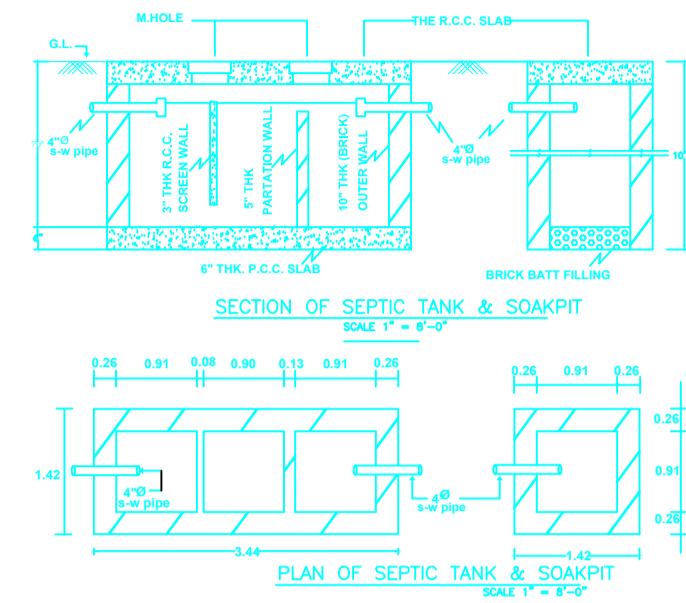
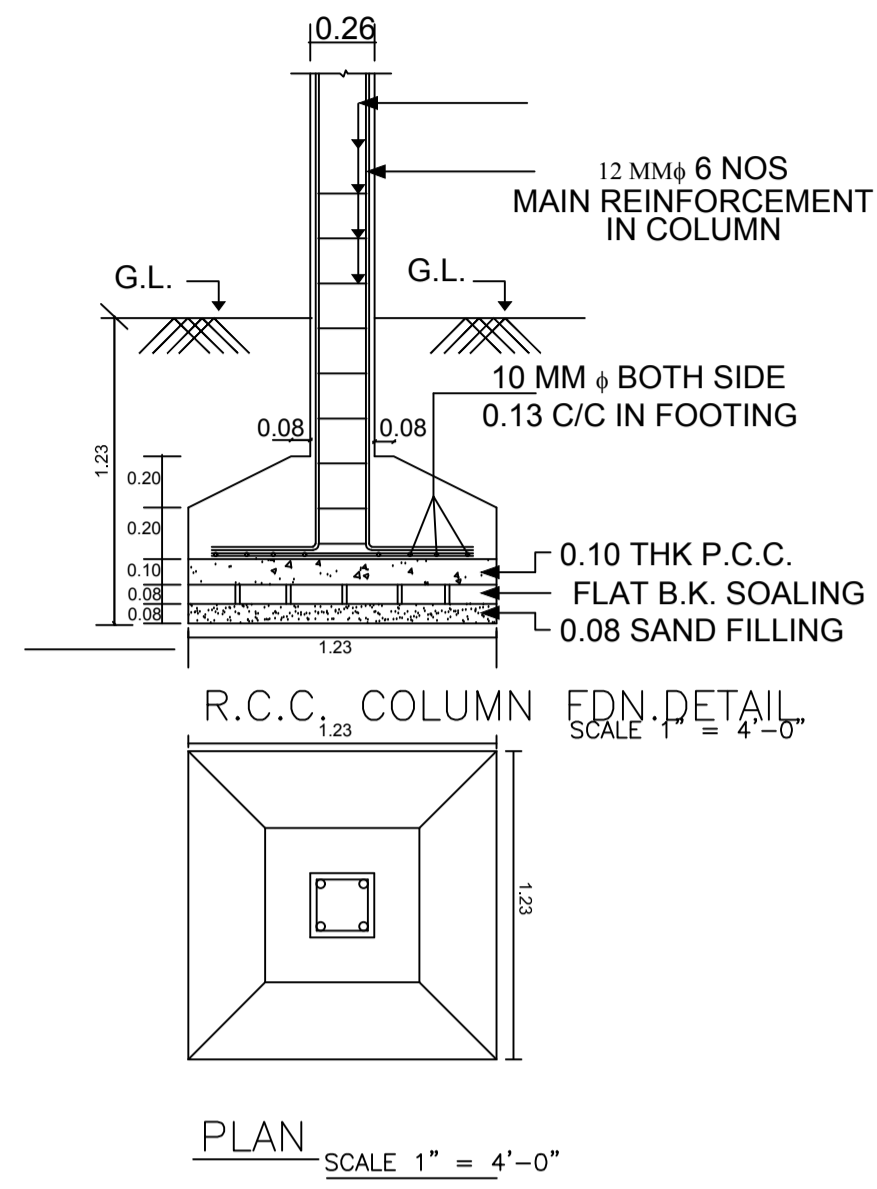

LTP NAME AND SIGNATURE	STRUCTURAL ENG'S NAME AND SIGNATURE	BUILDER NAME AND SIGNATURE
MD SHOAB ALAM KONPC/ENG/0004/2017		