

Proposal Basic Information	
Proposal File No.	KONPC/BI/0011/W15/2019
Owner Name	SMT KALAWATI DEVI
Khata No	369
Plot No	1726
Village Name	Kodarma
Use	Residential
SubUse	Bungalow/ Dwelling / Non Apartment

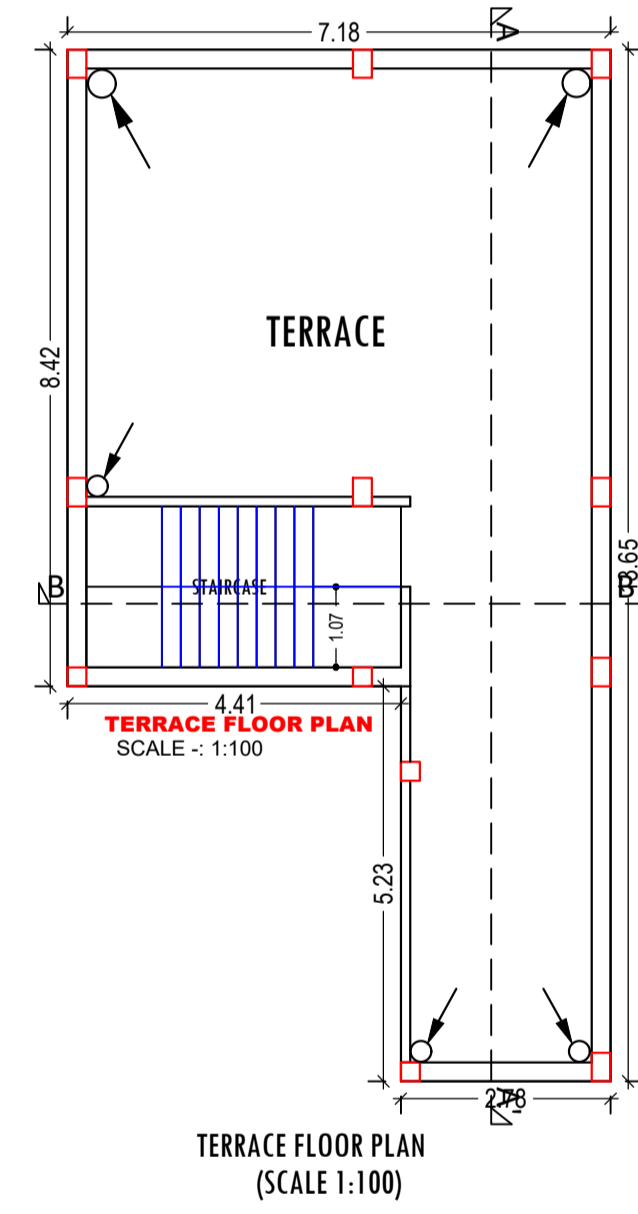
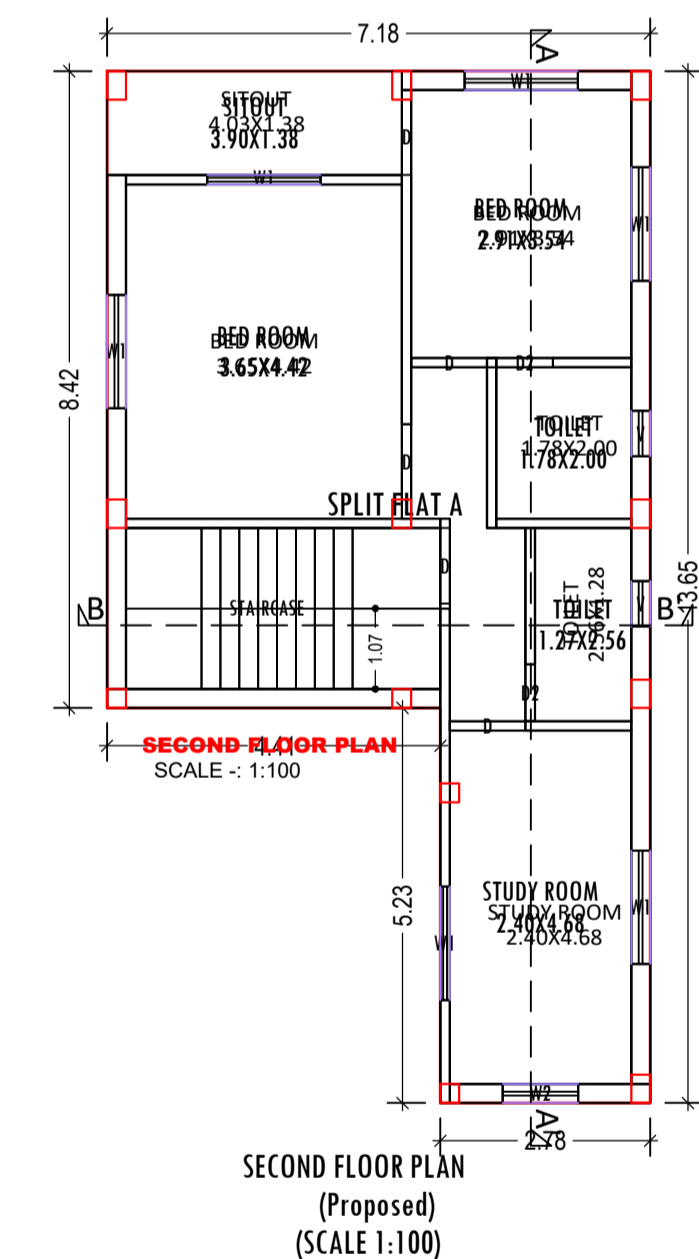
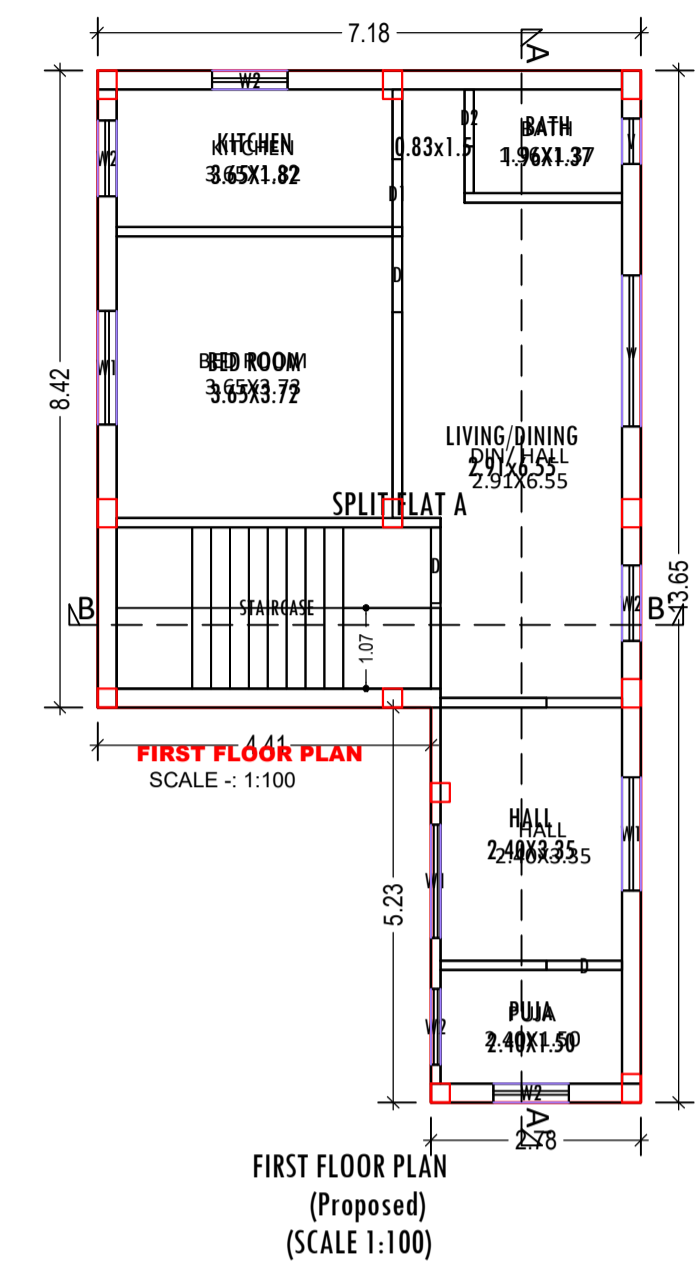
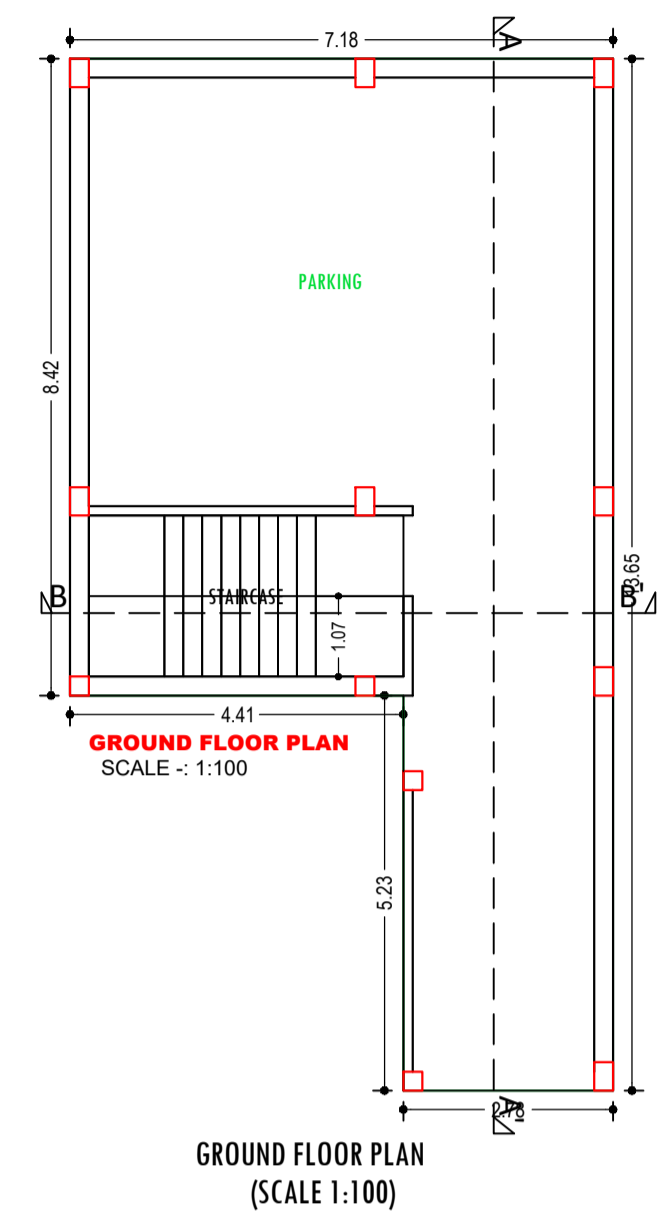
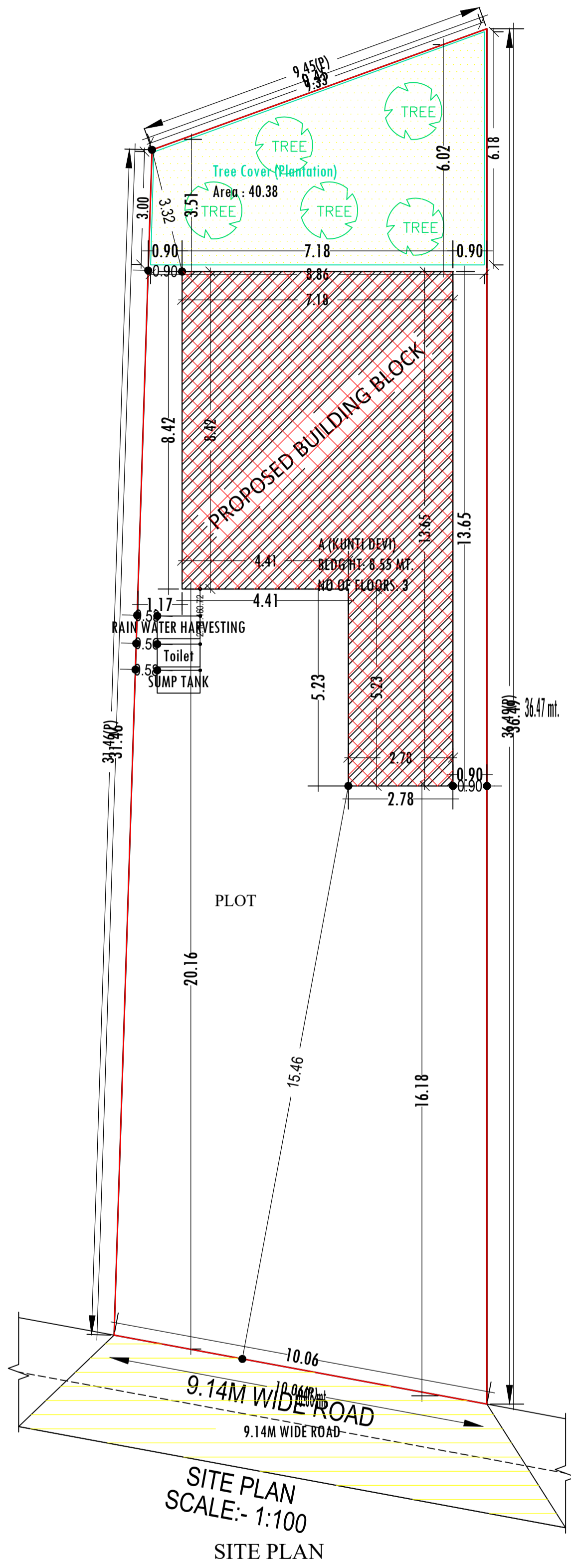

Building -A (KUNTI DEVI)

Floor Name	Total Built Up Area (Sq.mt.)	Deductions (Area in Sq.mt.)		Proposed FAR Area (Sq.mt.)	Add Area In FAR (Sq.mt.)	Total FAR Area (Sq.mt.)	Total Consumed Additional FAR Area (Sq.mt.)	Trmt (No.)
		Parking	Resi.					
Ground Floor	75.00	66.14	0.00	8.86	8.86	8.86	8.86	00
First Floor	75.00	0.00	75.00	0.00	75.00	75.00	75.00	01
Second Floor	75.00	0.00	75.00	0.00	75.00	75.00	75.00	00
Terrace Floor	0.00	0.00	0.00	0.00	0.00	0.00	0.00	00
Total	225.00	66.14	150.00	8.86	158.86	158.86	158.86	01

SCHEDULE OF DOOR:

BUILDING NAME	NAME	LENGTH	HEIGHT	NOS
A (KUNTI DEVI)	D2	2.13	2.13	03
A (KUNTI DEVI)	D1	0.90	2.13	01
A (KUNTI DEVI)	D	1.00	2.13	07

SCHEDULE OF WINDOW/VENTILATION:

BUILDING NAME	NAME	LENGTH	HEIGHT	NOS
A (KUNTI DEVI)	V	0.60	0.60	03
A (KUNTI DEVI)	W2	1.00	1.00	06
A (KUNTI DEVI)	W1	1.50	1.50	09
A (KUNTI DEVI)	w	2.00	2.00	09

UnitBUA Table for Building -A (KUNTI DEVI)

FLOOR	Name	UnitBUA Type	UnitBUA Area	Carpet Area	No. of Rooms	No. of Tenement
FIRST FLOOR PLAN	SPLIT FLAT A	FLAT	113.98	108.11	6	1
SECOND FLOOR PLAN	SPLIT FLAT A	FLAT	0.00	0.00	6	0
Total:	-	-	113.98	108.11	12	1

AREA STATEMENT		VERSION NO. : 1.0.39
KODERMA NAGAR PANCHAYAT		VERSION DATE: 29/04/2019
PROJECT DETAIL:		
Region: JHARKHAND URBAN	Plot Use: Residential	
LOCAL BODIES	Plot SubUse: Bungalow/ Dwelling / Non Apartment	
District: KODERMA	Plot/Nearyby/Religious/Structure: NA	
Authority: KODERMA NAGAR PANCHAYAT	Plot/SubPlot No: 1726	
Inward No: KONPC/BI/0011/W15/2019	North: Road Width - 9.14M WIDE ROAD	
Application Type: General Proposal	South: Plot No. - LAND OF BHIKHAN SINGH	
Project Type: Building Permission	East: Plot No. - GOVIND PANDIT	
Nature of Development: New	West: Plot No. - NIZ MOKIR & OTHERS	
Location of Development Area: Old Area		
AREA DETAILS:		
AREA OF PLOT (Minimum)	(A)	SQ.MT. 318.41
NET AREA OF PLOT(Gross Plot Area - Deduction from Gross Plot area)	(A-Deductions)	318.41
Deduction for Balance Plot Area(from Gross Plot Area)		
Common Plot		40.38
Total		40.38
BALANCE AREA OF PLOT(Net Plot Area - Recreational/Amenity space)	(A-Deductions)	278.03
PLOT AREA FOR COVERAGE(Net Plot Area)	(A-Deductions)	318.41
Plot Area for FAR (Net Plot Area + RoadWidening Area)	(A-Deductions)	318.41
COVERAGE CHECK		
Permissible Coverage area (60.00 %)		191.05
Proposed Coverage Area (23.55 %)		75.00
Total Prop. Coverage Area (23.55 %)		75.00
Balance coverage area (36.45 %)		116.05
FAR CHECK		
Perm. FAR Area (2.00)		636.82
Total Perm. FAR area		636.82
Residential FAR		150.00
Proposed FAR Area		158.86
Total Proposed FAR Area		158.86
Consumed FAR (Factor)		0.50
Balance FAR Area		477.96
BUILT UP AREA CHECK		
Total Proposed BuiltUp Area		225.00
ARCHITECT (Regd) Amrendra Kumar		
ENGINEER (Regd)		
SUPERVISOR (Regd)		
OWNER (Regd) SMT KALAWATI DEVI		
DEVELOPMENT AUTHORITY		LOCAL BODY

Buildingwise Floor FAR Details

Floor Name	Building Name A (KUNTI DEVI)		Total	
	Proposed Built Up Area (Sq.mt.)	Proposed FAR Area (Sq.mt.)	Total Proposed Built Up Area (Sq.mt.)	Total FAR Area (Sq.mt.)
Ground Floor	75.00	8.86	75.00	8.86
First Floor	75.00	75.00	75.00	75.00
Second Floor	75.00	75.00	75.00	75.00
Terrace Floor	0.00	0.00	0.00	0.00
Total	225.00	158.86	225.00	158.86

Building USE/SUBUSE Details

Building Name	Building Use	Building SubUse	Building Structure
A (KUNTI DEVI)	Residential	Bungalow/ Dwelling / Non Apartment	Non-Highrise

FAR & Tenement Details (Table 4c-1)

Building	No. of Same Bldg	Total Built Up Area (Sq.mt.)	Deductions (Area in Sq.mt.)		Proposed FAR Area (Sq.mt.)	Add Area In FAR (Sq.mt.)	Total FAR Area (Sq.mt.)	Total Consumed Additional FAR Area (Sq.mt.)	Trmt (No.)
			Parking	Resi.					
A (KUNTI DEVI)	1	225.00	66.14	150.00	8.86	158.86	158.86	158.86	01
Grand Total :	1	225.00	66.14	150.00	8.86	158.86	158.86	158.86	01

COLOR INDEX	
PLOT BOUNDARY	
ABUTTING ROAD	
PROPOSED CONSTRUCTION	
COMMON PLOT	
ROAD WIDENING AREA	
EXISTING (To be retained)	
EXISTING (To be demolished)	

LTP NAME AND SIGNATURE	STRUCTURAL ENG'S NAME AND SIGNATURE	BUILDER NAME AND SIGNATURE	DIGITAL SIGNATURE
Amrendra Kumar KONPC/SUP/002/2017			

Proposal Basic Information	
Proposal File No.	KONPC/BI/0011/W15/2019
Owner Name	SMT KALAWATI DEVI
Khata No	369
Plot No	1726
Village Name	Kodarma
Use	Residential
SubUse	Bungalow/ Dwelling / Non Apartment

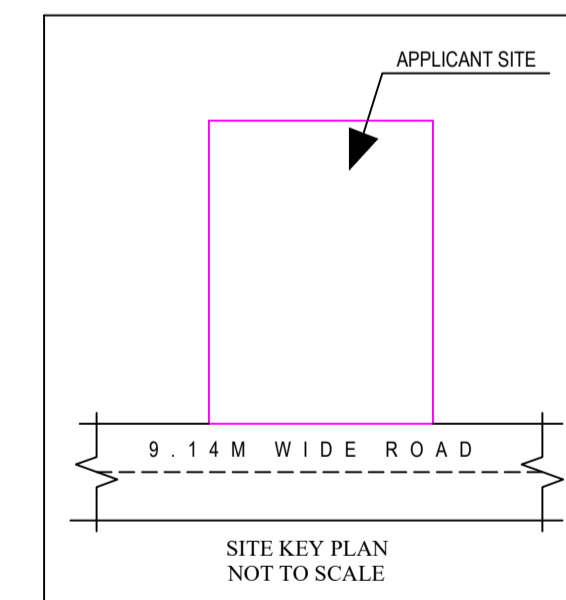
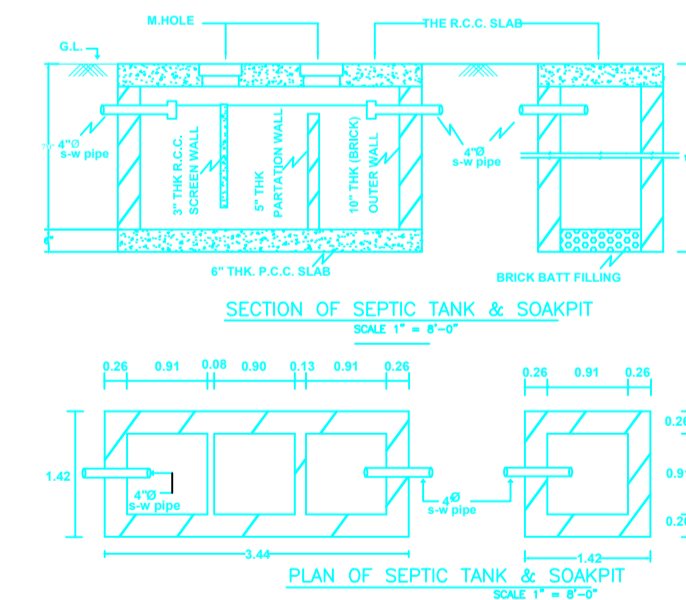
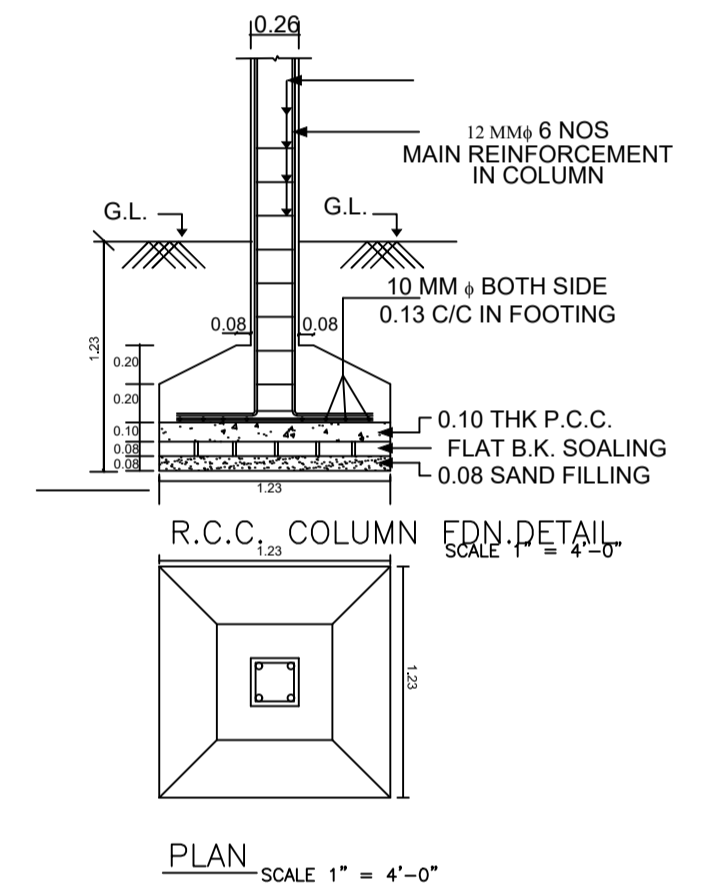
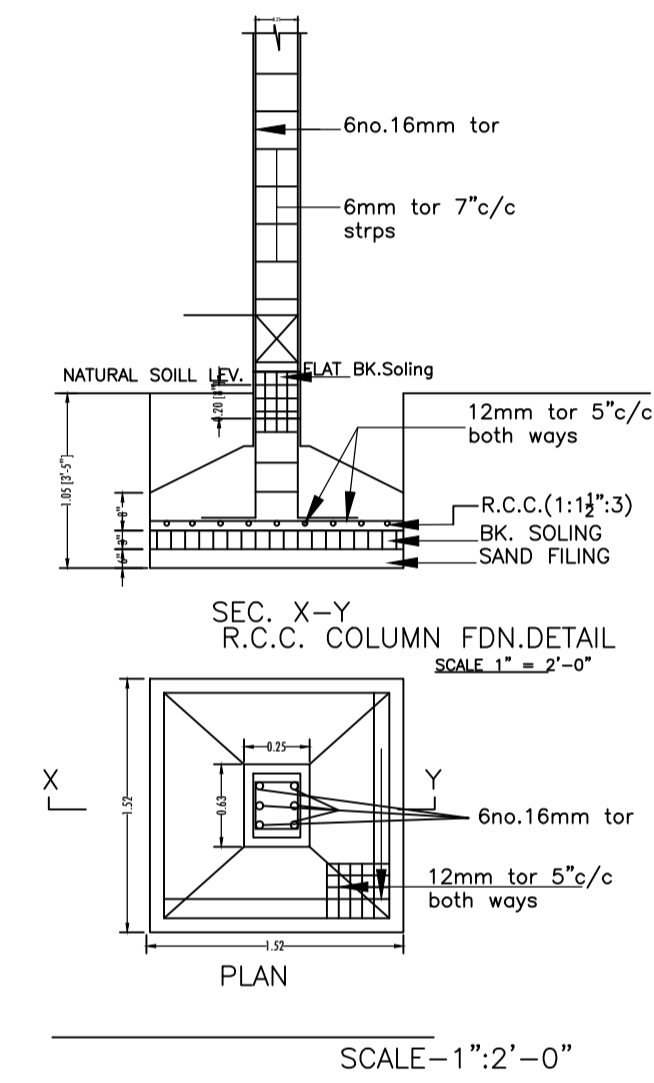
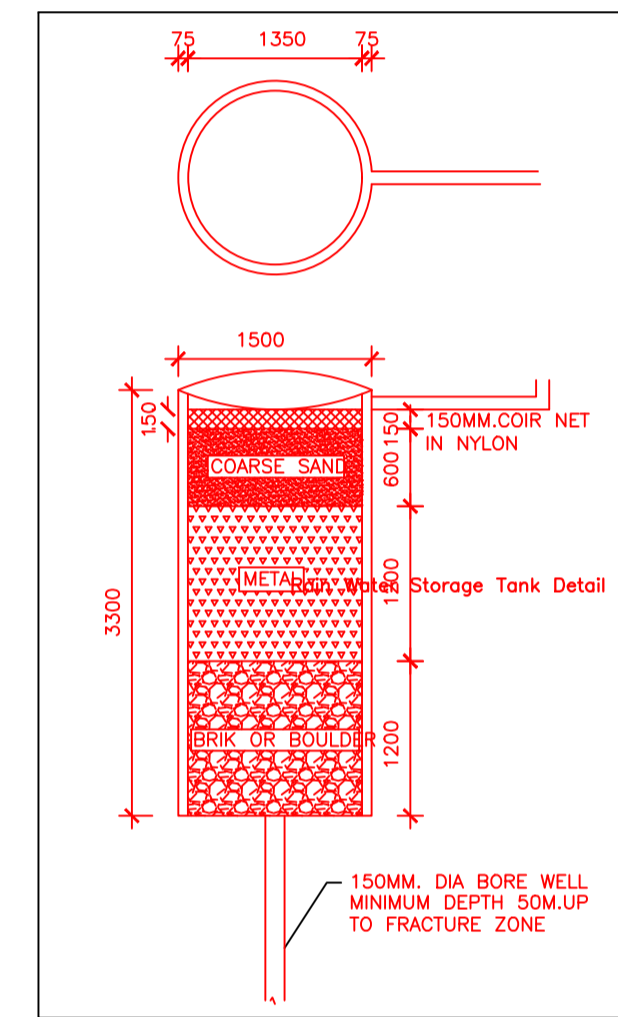
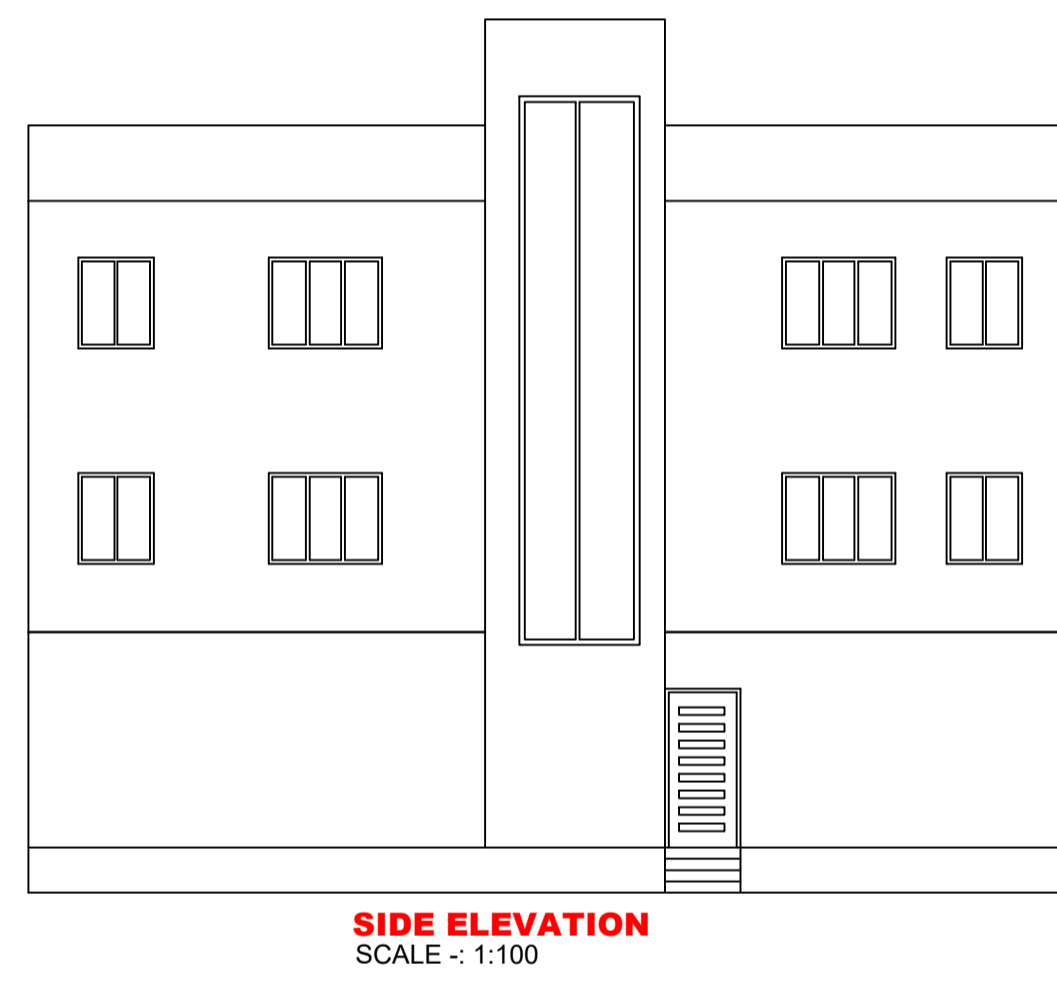
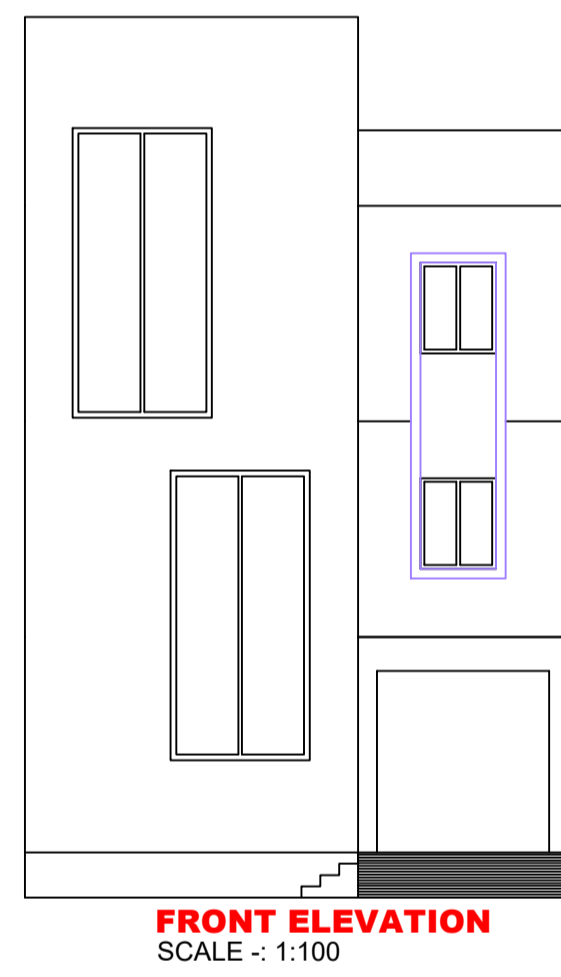
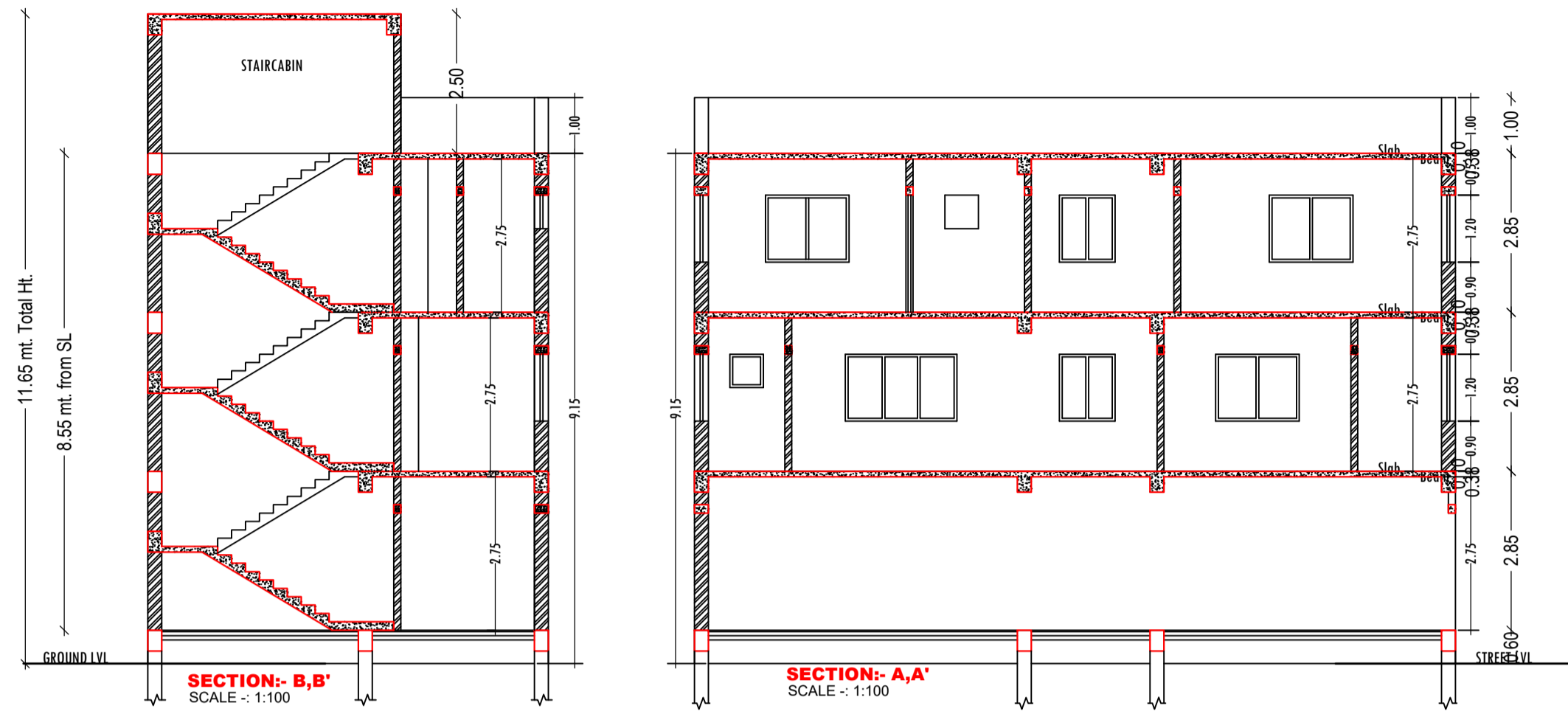

LTP NAME AND SIGNATURE	STRUCTURAL ENG'S NAME AND SIGNATURE	BUILDER NAME AND SIGNATURE	DIGITAL SIGNATURE
Amrendra Kumar KONPC/SUP/0002/2017			