

SITE PLAN

FAR & Tenement Details (Table 4c-1)

Building	No. of Same Bldg	Total Built Up Area (Sq.mt.)	Deductions (Area in Sq.mt.)		Proposed FAR Area (Sq.mt.)	Total FAR Area (Sq.mt.)	Total Consumed Additional FAR Area (Sq.mt.)	Trnmt (No.)
			Balcony	Resi.				
SHAKUNTALA (SINGH)	1	330.81	2.16		328.65	328.65	328.65	01
<b>Grand Total :</b>	<b>1</b>	<b>330.81</b>	<b>2.16</b>		<b>328.65</b>	<b>328.65</b>	<b>328.65</b>	<b>01</b>

Proposal Basic Information

Proposal File No.	KONPC/BP/0025/W14/2020
Owner Name	SHAKUNTALA SINGH
Khata No	29
Plot No	4337
Village Name	Kodarma
Use	Residential
SubUse	Bungalow/ Dwelling / Non Apartment

AREA STATEMENT	VERSION NO. : 1.0.65
KODERMA NAGAR	VERSION DATE: 16/10/2020
PANCHAYAT	
PROJECT DETAIL:	
Region: JHARKHAND URBAN LOCAL BODIES	Plot Use: Residential
District: KODERMA	Plot SubUse: Bungalow/ Dwelling / Non Apartment
Authority: KODERMA NAGAR PANCHAYAT	PlotNearbyReligiousStructure: NA
Inward No: KONPCBP/0025/W14/2020	Plot/SubPlot No: 4337
Application Type: General Proposal	North: -
Project Type: Building Permission	South: -
Nature of Development: New	East: -
Location of Development Area: Old Area	West: -
AREA DETAILS:	SQ.MT.
AREA OF PLOT (Minimum)	(A) 349.87
NET AREA OF PLOT(Gross Plot Area - Deduction from Gross Plot area)	(A-Deductions) 349.87
Deduction for Balance Plot Area(from Gross Plot Area)	
Common Plot	19.84
Total	19.84
BALANCE AREA OF PLOT(Net Plot Area - Recreational/Amenity space)	(A-Deductions) 330.03
PLOT AREA FOR COVERAGE(Net Plot Area)	(A-Deductions) 349.87
Plot Area for FAR (Net Plot Area + RoadWidening Area)	(A-Deductions) 349.87
COVERAGE CHECK	
Permissible Coverage area ( 60.00 % )	209.92
Proposed Coverage Area ( 46.33 % )	162.09
Total Prop. Coverage Area ( 46.33 % )	162.09
Balance coverage area ( 13.67 % )	47.83
FAR CHECK	
Perm. FAR Area ( 1.500 )	524.80
Total Perm. FAR area	524.80
Residential FAR	328.65
Proposed FAR Area	328.65
Total Proposed FAR Area	328.65
Consumed FAR (Factor)	0.94
Balance FAR Area	196.15
BUILT UP AREA CHECK	
Total Proposed BuiltUp Area	330.81
ARCHITECT (Regd)	BIJOY KUMAR SINGH
ENGINEER (Regd)	
SUPERVISOR (Regd)	
OWNER (Regd)	SHAKUNTALA SINGH
DEVELOPMENT AUTHORITY	LOCAL BODY

COLOR INDEX	
PLOT BOUNDARY	
ABUTTING ROAD	
PROPOSED CONSTRUCTION	
COMMON PLOT	
ROAD WIDENING AREA	
EXISTING (To be retained)	
EXISTING (To be demolished)	

Buildingwise Floor FAR Details

Floor Name	Building Name		Total	
	Proposed Built Up Area (Sq.mt.)	Proposed FAR Area (Sq.mt.)	Total Proposed Built Up Area (Sq.mt.)	Total FAR Area (Sq.mt.)
Ground Floor	162.09	162.09	162.09	162.09
First Floor	168.72	166.56	168.72	166.56
Terrace Floor	0.00	0.00	0.00	0.00
<b>Total :</b>	<b>330.81</b>	<b>328.65</b>	<b>330.81</b>	<b>328.65</b>

Building USE/SUBUSE Details

Building Name	Building Use	Building SubUse	Building Structure
SHAKUNTALA (SINGH)	Residential	Bungalow/ Dwelling / Non Apartment	Non-Highrise

LTP NAME AND SIGNATURE	STRUCTURAL ENG'S NAME AND SIGNATURE	BUILDER NAME AND SIGNATURE	DIGITAL SIGNATURE
BIJOY KUMAR SINGH KONPC/SUP/0007/2017			

Proposal Basic Information	
Proposal File No.	KONPC/BI/0025/W14/2020
Owner Name	SHAKUNTALA SINGH
Khata No	29
Plot No	4337
Village Name	Kodarma
Use	Residential
SubUse	Bungalow/ Dwelling / Non Apartment

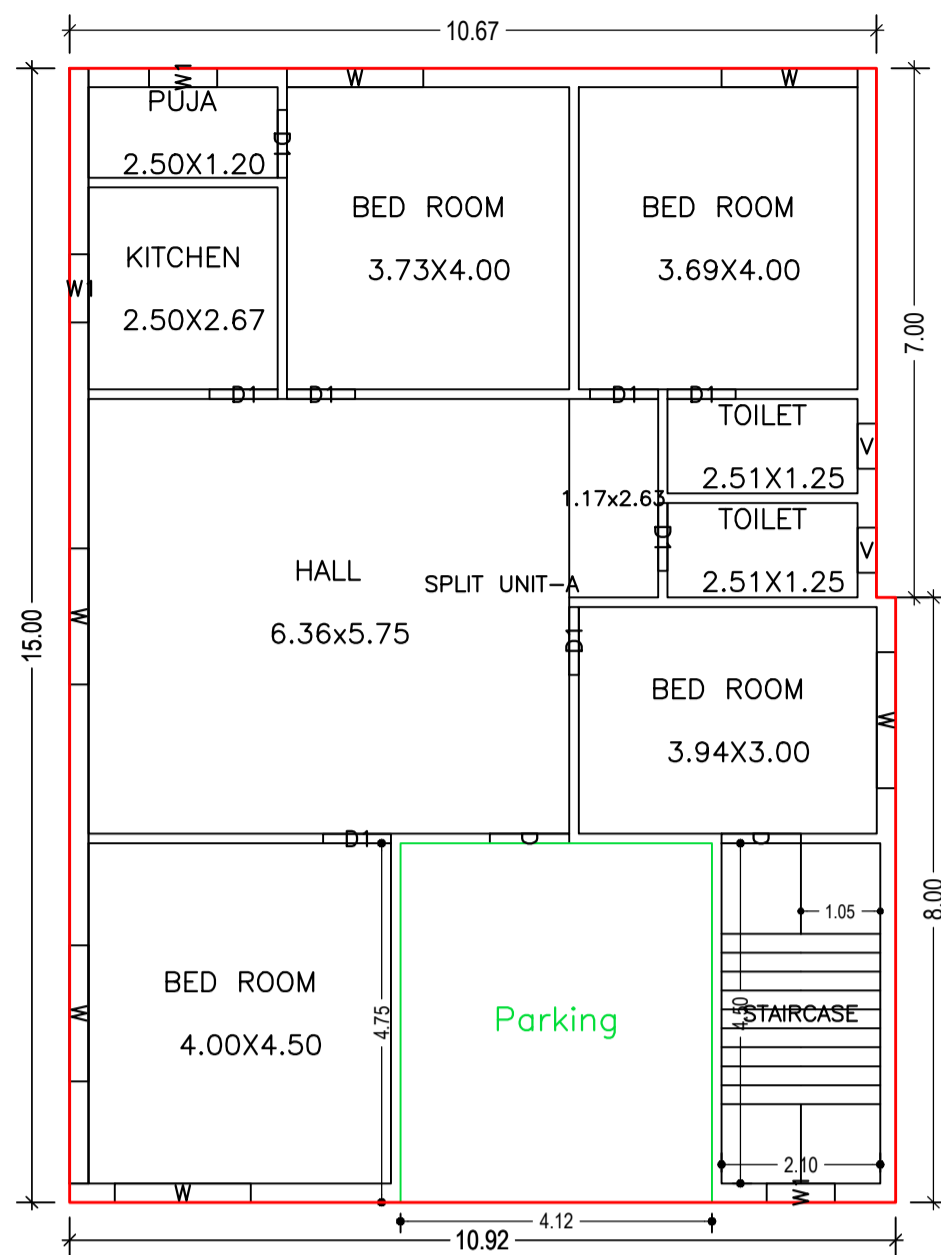

GROUND FLOOR PLAN (Proposed) (SCALE 1:100)

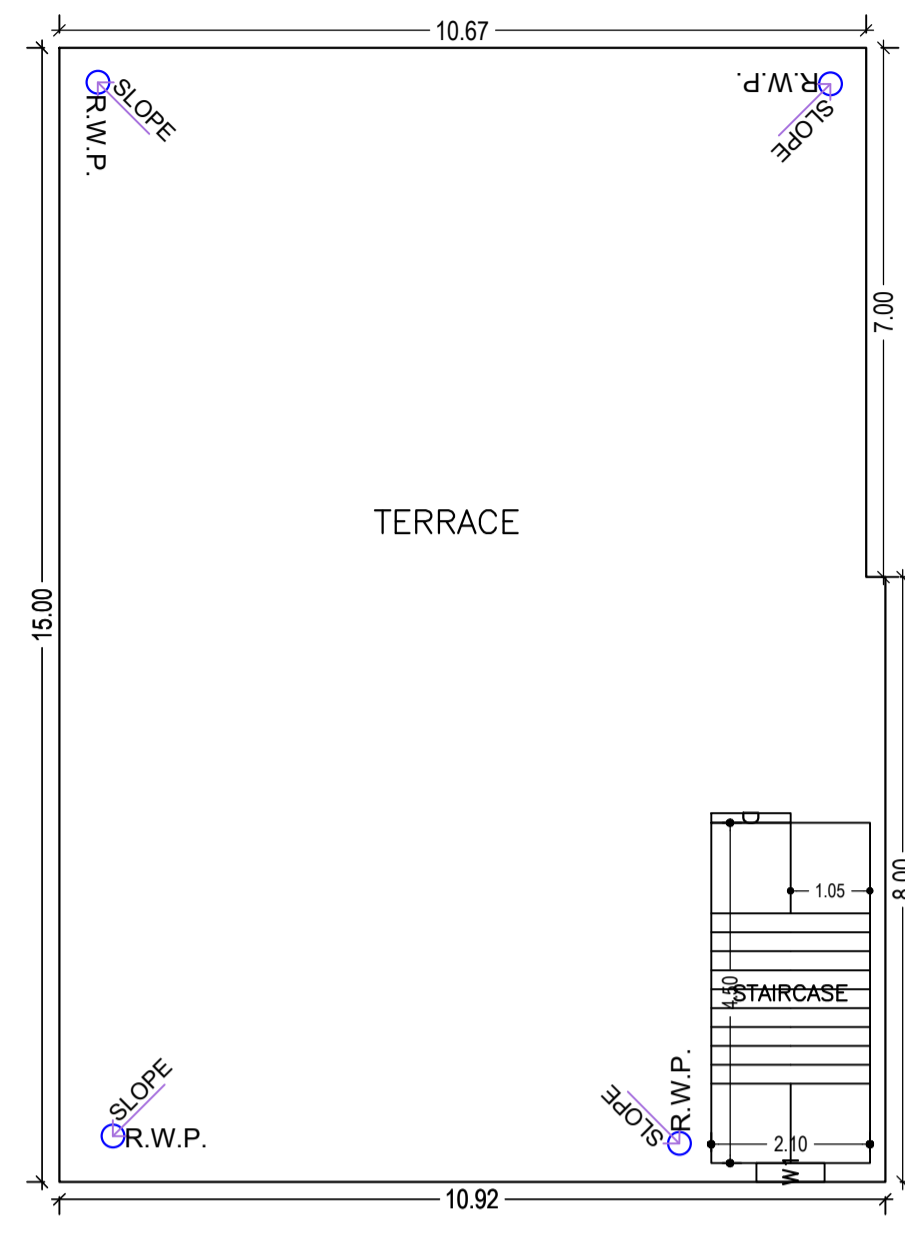

TERRACE FLOOR PLAN (SCALE 1:100)

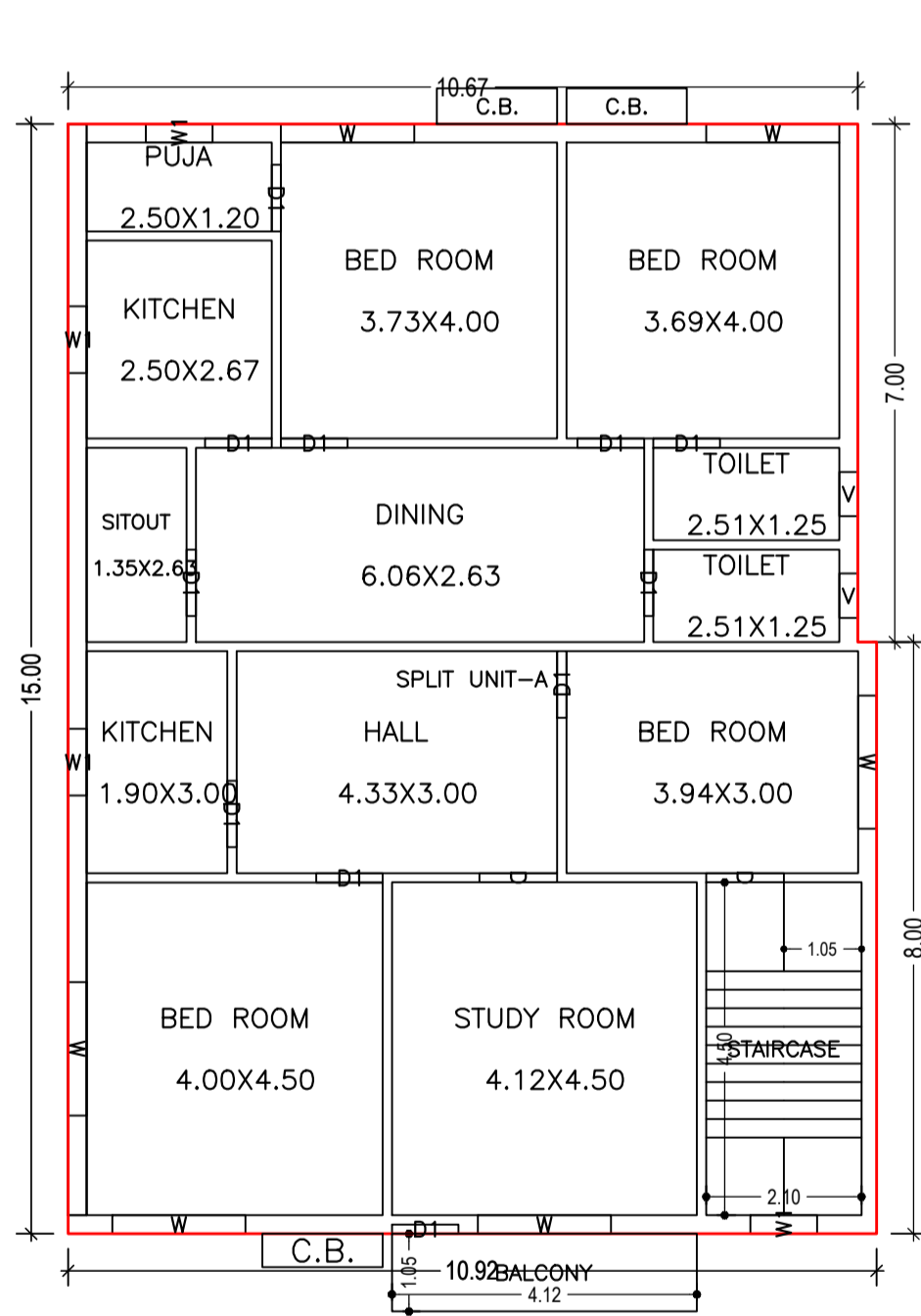

FIRST FLOOR PLAN (Proposed) (SCALE 1:100)

Building :SHAKUNTALA (SINGH)

Floor Name	Total Built Up Area (Sq.mt.)	Deductions (Area in Sq.mt.)	Proposed FAR Area (Sq.mt.)	Total FAR Area (Sq.mt.)	Total Consumed Additional FAR Area (Sq.mt.)	Trmt (No.)
Ground Floor	162.09	0.00	162.09	162.09	162.09	01
First Floor	168.72	2.16	166.56	166.56	166.56	00
Terrace Floor	0.00	0.00	0.00	0.00	0.00	00
Total:	330.81	2.16	328.65	328.65	328.65	01
Total Number of Same Buildings	1					
Total:	330.81	2.16	328.65	328.65	328.65	01

SCHEDULE OF DOOR:

BUILDING NAME	NAME	LENGTH	HEIGHT	NOS
SHAKUNTALA (SINGH)	D1	0.90	2.10	18
SHAKUNTALA (SINGH)	D	1.05	2.10	04

SCHEDULE OF WINDOW/VENTILATION:

BUILDING NAME	NAME	LENGTH	HEIGHT	NOS
SHAKUNTALA (SINGH)	V	0.60	1.20	04
SHAKUNTALA (SINGH)	W1	0.90	1.20	08
SHAKUNTALA (SINGH)	W	1.80	1.20	12

UnitBUA Table for Building :SHAKUNTALA (SINGH)

FLOOR	Name	UnitBUA Type	UnitBUA Area	Carpet Area	No. of Rooms	No. of Tenement
GROUND FLOOR PLAN	SPLIT UNIT-A	FLAT	328.51	316.81	9	1
FIRST FLOOR PLAN	SPLIT UNIT-A	FLAT	0.00	0.00	13	0
Total:	-	-	328.51	316.81	22	1

Balcony Calculations Table

FLOOR	SIZE	AREA	TOTAL AREA
FIRST FLOOR PLAN	1.05 X 4.12 X 1 X 1	4.33	4.33
Total	-	-	4.33

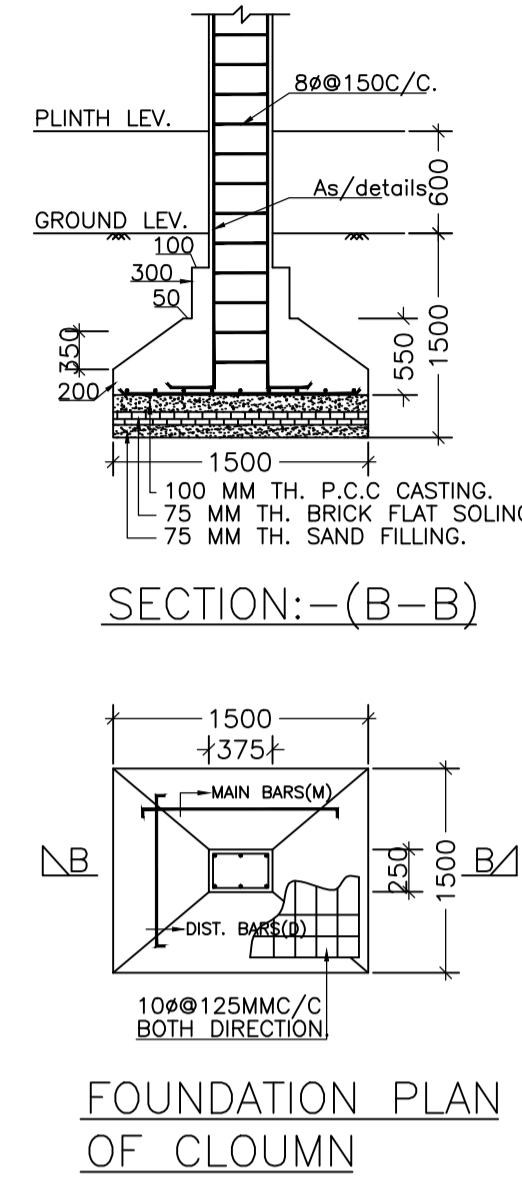

FOUNDATION PLAN OF COLUMN

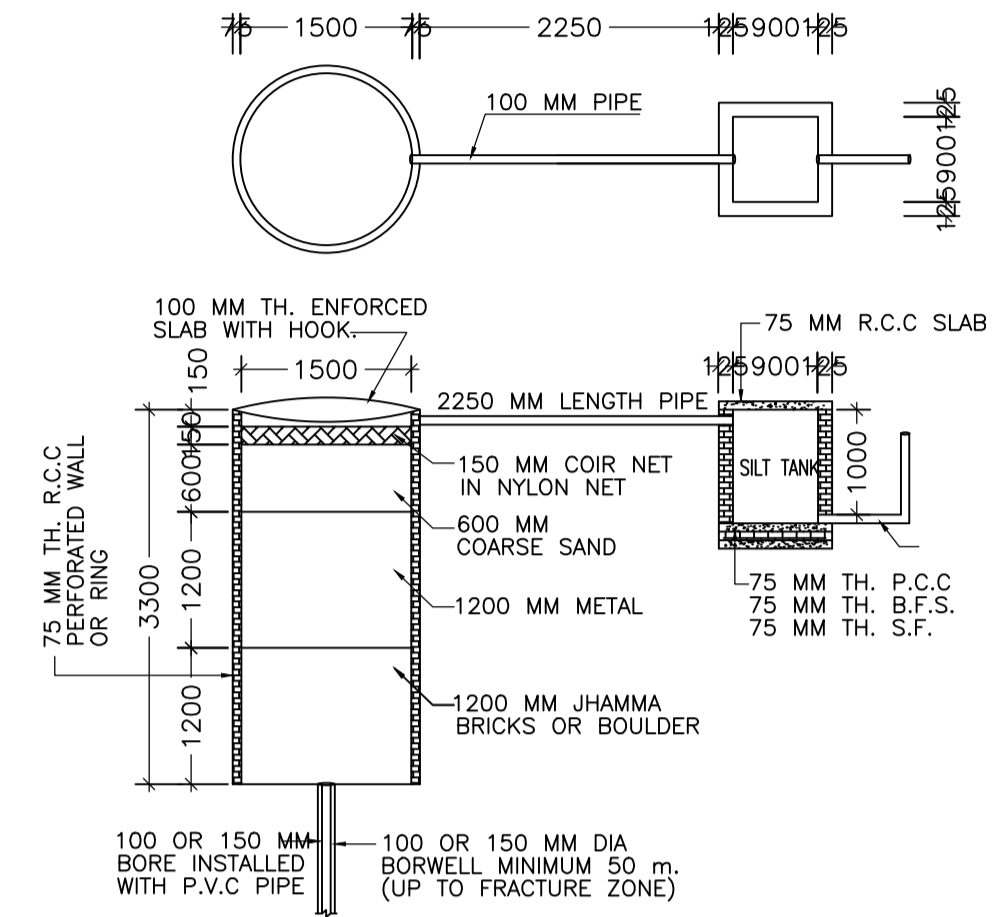

DETAIL OF GROUND WATER RECHARGING PIT WITH SILT TANK

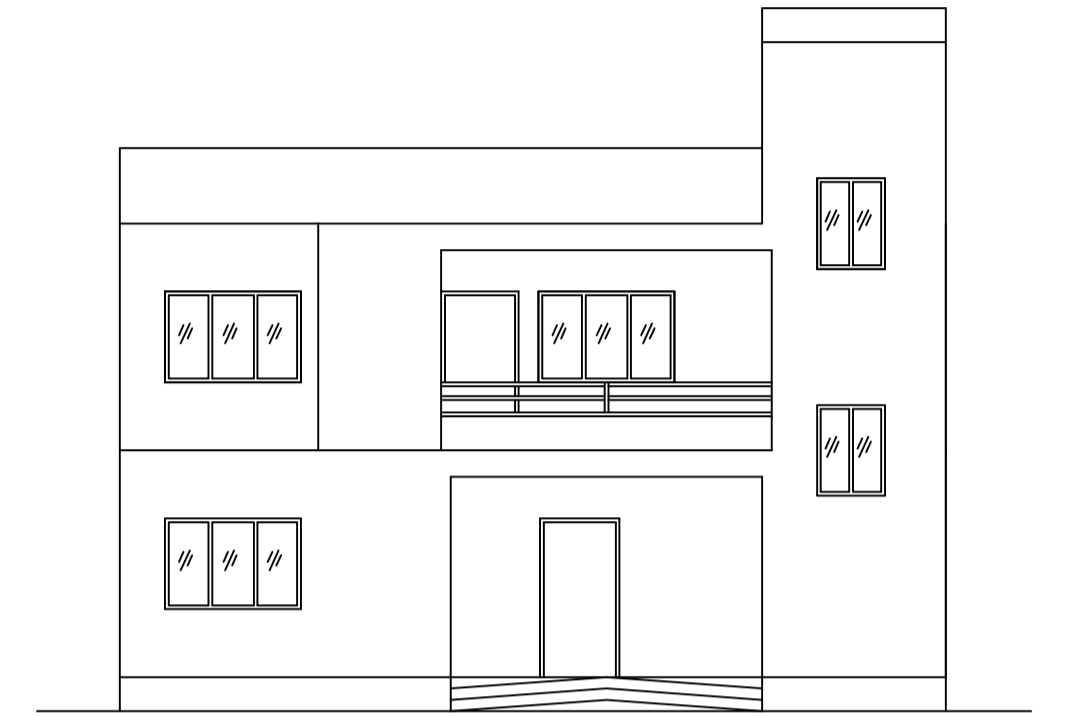

FRONT ELEVATION

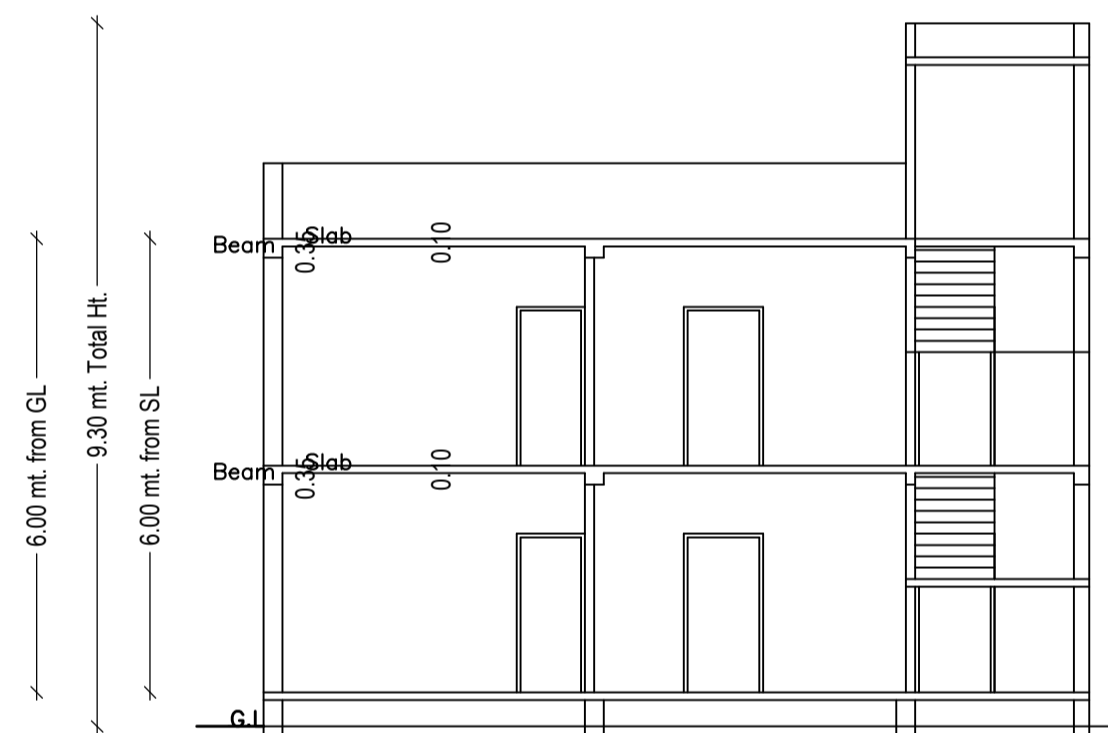

SECTION AT X-X

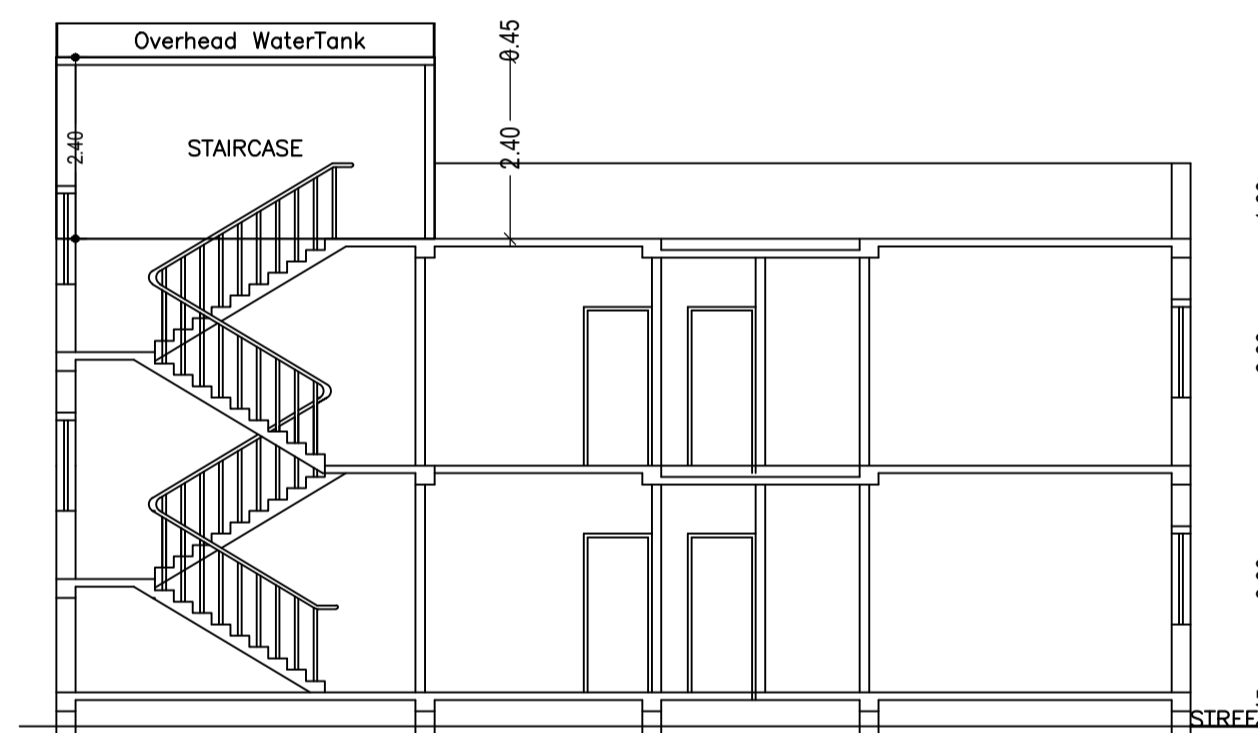

SECTION AT Y-Y

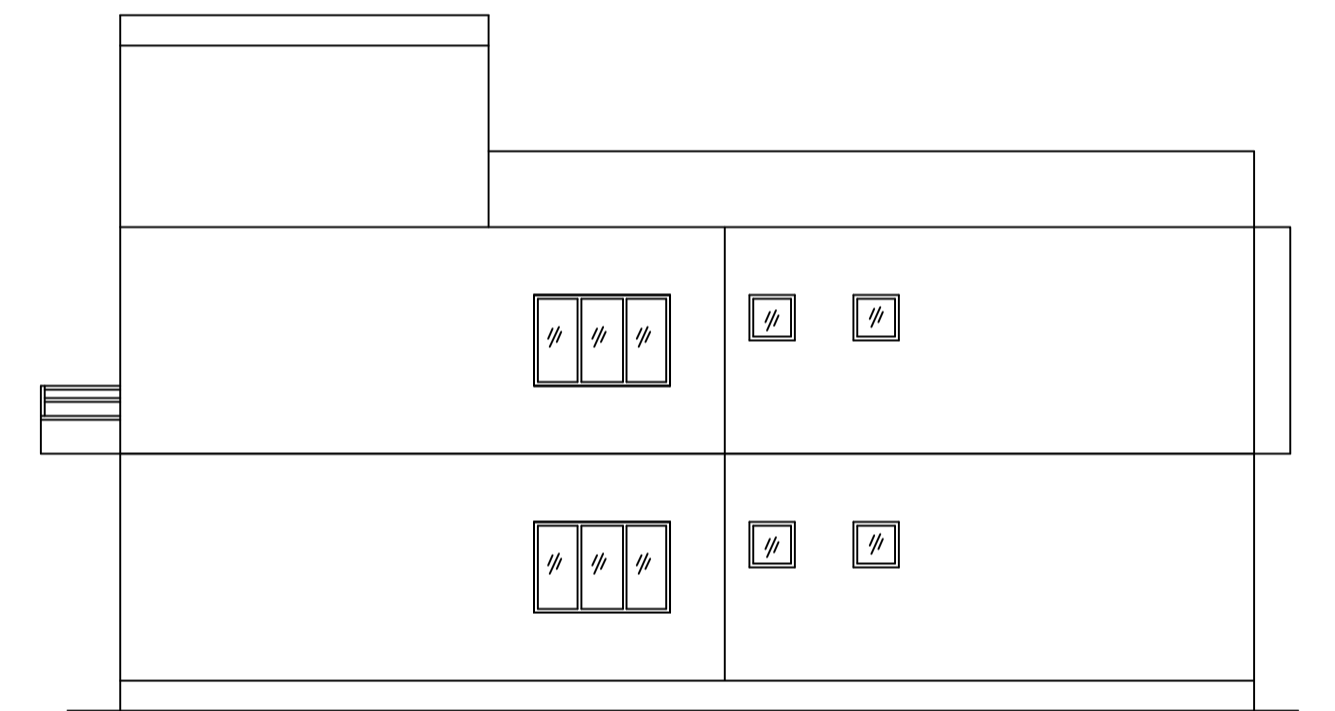

SIDE ELEVATION

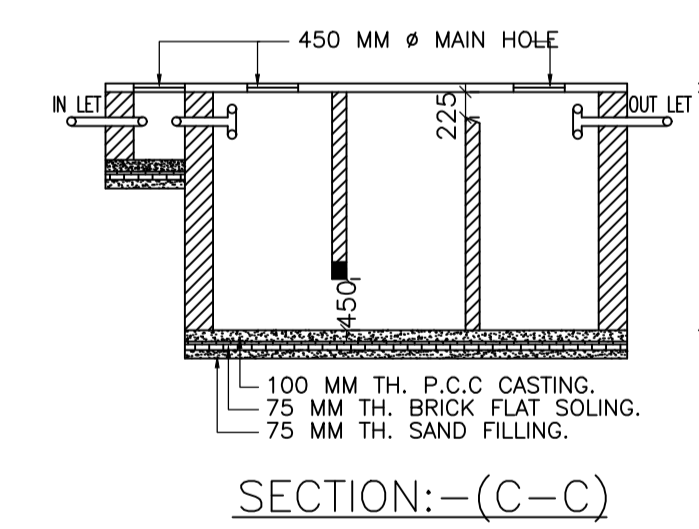

SECTION:-(C-C)

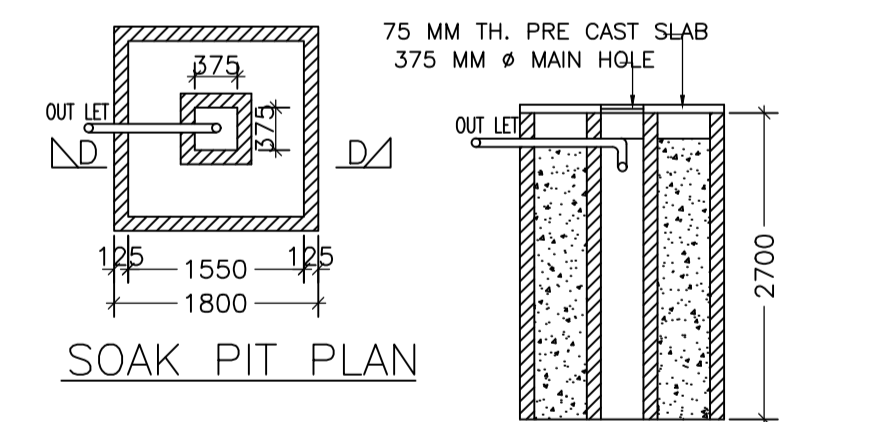

SOAK PIT PLAN

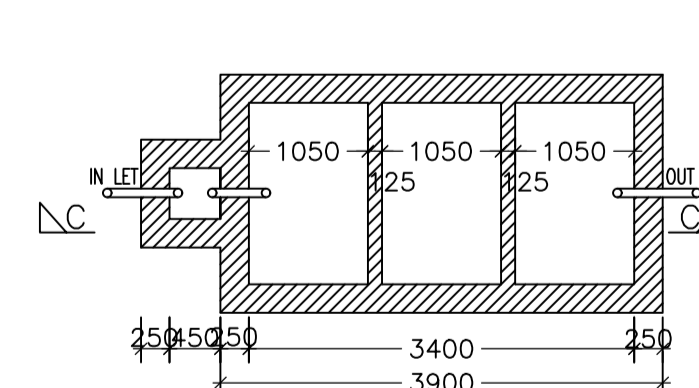

SECTION:-(D-D)

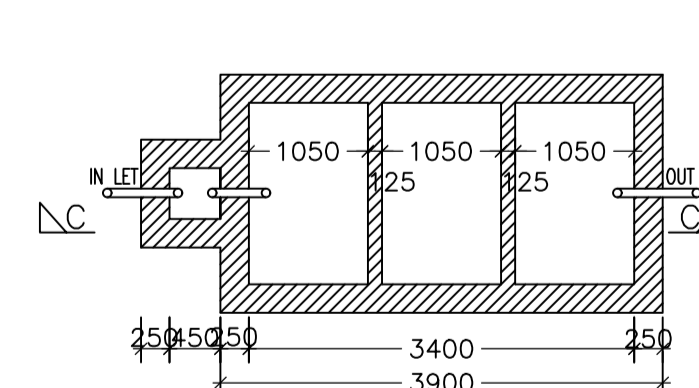

SEPTICK TANK PLAN

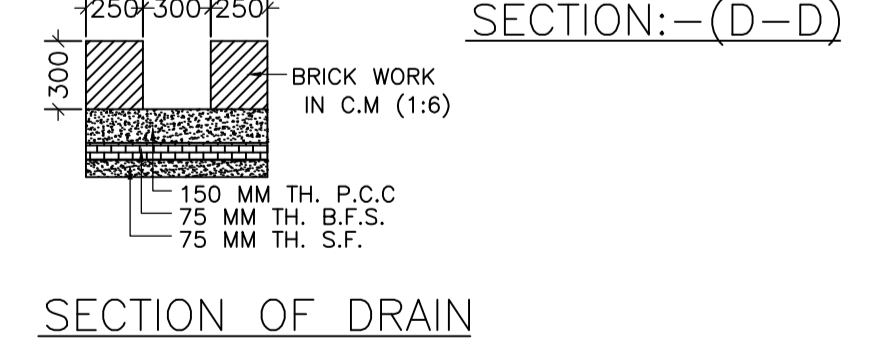

SECTION OF DRAIN

KEY -- PLAN  
SCALE : (N.T.S)

LTP NAME AND SIGNATURE	STRUCTURAL ENG'S NAME AND SIGNATURE	BUILDER NAME AND SIGNATURE	DIGITAL SIGNATURE
BIJOY KUMAR SINGH KONPC/SUP/0007/2017			