

Project Title :MRS JHAMNI DEVI

| | | |
|---|--|--------------------------|
| AREA STATEMENT: KODARMA NAGAR PANCHAYAT | | VERSION NO: 1.0.27 |
| PROJECT DETAIL: | | VERSION DATE: 16/10/2020 |
| Plot No.: | Plot Use: Residential | |
| Region: JHARKHAND URBAN LOCAL BODIES | Plot Subtype: Bungalow/ Dwelling / Non Apartment | |
| District: KODARMA | Land Use Zone: NA | |
| Application Type: General Proposal | Abutting Road Width: - | |
| Nature of Development: New | Reverse Survey No/Survey No: - | |
| Location: Old Area | Thana No: - | |
| Sub Location: NA | Holding No: - | |
| Village/Mauza Name: - | Khata No: - | |
| Ward No: - | North: - | |
| Road/Street: - | South: - | |
| | East: - | |
| | West: - | |

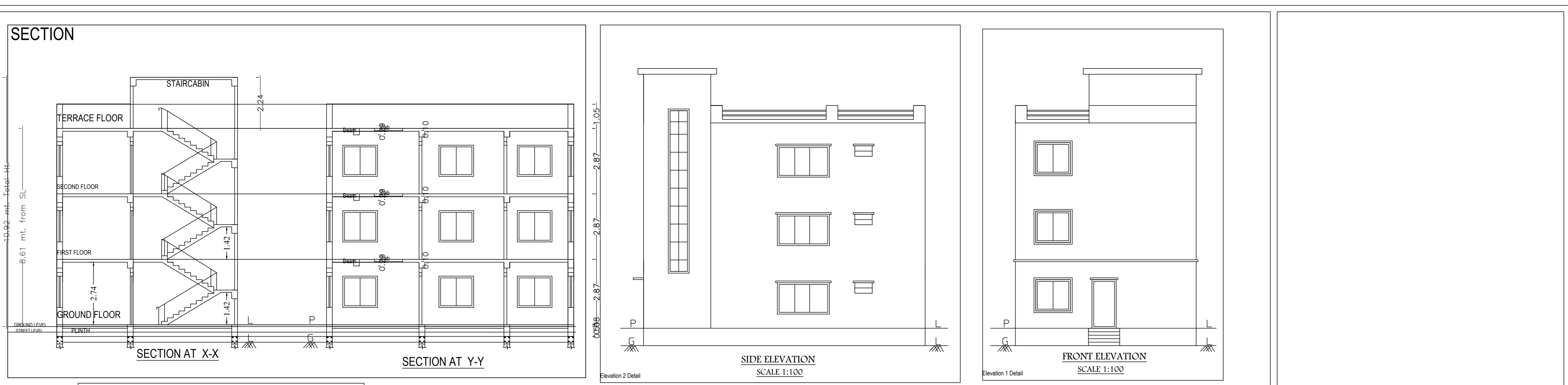

| | | |
|--|----------------|------------|
| AREA DETAILS: | | SQ. MT. |
| AREA OF PLOT (Minimum) | (A) | 162.46 |
| Net Plot Area (Gross Plot Area - Deduction from Gross Plot area) | (A-Deductions) | 162.46 |
| Deductions for Balance Plot Area (from Gross Plot Area) | | |
| COP Area | | 21.44 |
| Total | | 21.44 |
| Balance Plot Area (Net Plot Area - Recreational/Amenity spaces) | (A-Deductions) | 141.02 |
| Plot Area for Coverage (Net Plot Area) | (A-Deductions) | 162.46 |
| Plot Area for FSI (Net Plot Area - Road/Widening Area) | (A-Deductions) | 162.46 |
| Accessory Use Area | | 0.91 |
| COVERAGE CHECK | | |
| Proposed Coverage Area (57.96%) | | 94.16 |
| Total Coverage Area (57.96%) | | 94.16 |
| FAR CHECK | | |
| Proposed Area of FAR | | 282.48 |
| Total Area of FAR | | 282.48 |
| BUILT UP AREA CHECK | | |
| Total Proposed Builtup Area | | 282.48 |
| ARCH/ ENGG/ SUPERVISOR (Regd) | | OWNER |
| DEVELOPMENT AUTHORITY | | LOCAL BODY |

| | |
|-------------------------------|---|
| COLOR INDEX | |
| FLAT BOUNDARY | █ |
| ABUTTING ROAD | █ |
| PROPOSED WORK (COVERAGE AREA) | █ |
| EXISTING (To be retained) | █ |
| EXISTING (To be demolished) | █ |

| | | |
|-----------------------------------|----------|-----------|
| Color Index: PARKING CALCULATION: | | |
| Parking Type | Prop No. | Prop Area |
| Other Parking | 1 | 13.85 |
| Total Area | 1 | 13.85 |

| | | | | | |
|----------------------|--------------------------------|--------------|-------------|--------------|--------------|
| MARGIN DETAIL: | | | | | |
| Building / Wing Name | Road Name | Front Margin | Rear Margin | Side1 Margin | Side2 Margin |
| A (MRS JHAMNI DEVI) | 4.26 MTR WIDE ROAD Access Road | 2.05 | 1.59 | 1.04 | 0.95 |

| | | | | | |
|-------------------------------------|------------------|------------------------------|----------------------------|-------------------------|------------|
| FAR & Tenement Details (Table 4c-1) | | | | | |
| Building | No. of Same Bldg | Total Built Up Area (Sq.mt.) | Proposed FAR Area (Sq.mt.) | Total FAR Area (Sq.mt.) | Tnmt (No.) |
| A (MRS JHAMNI DEVI) | 1 | 282.48 | 282.48 | 282.48 | 01 |
| Grand Total: | 1 | 282.48 | 282.48 | 282.48 | 01 |

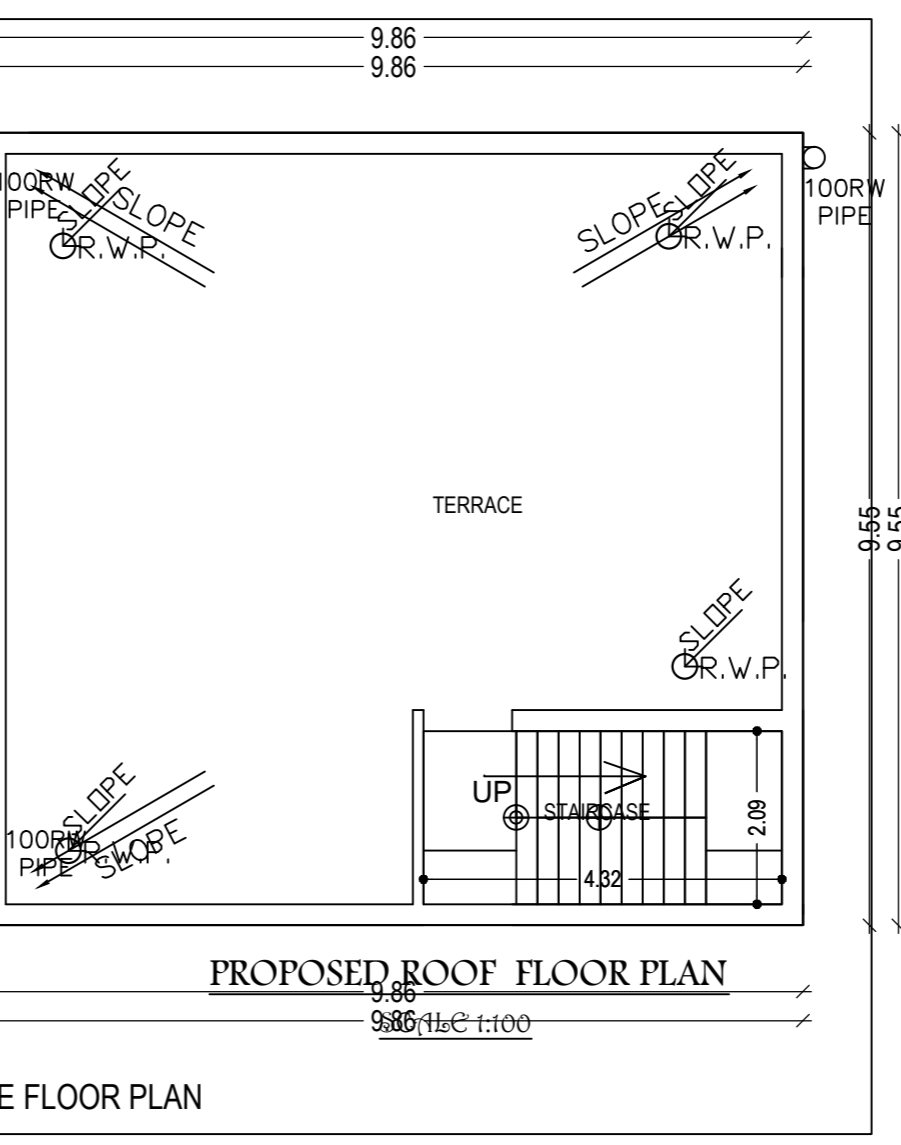
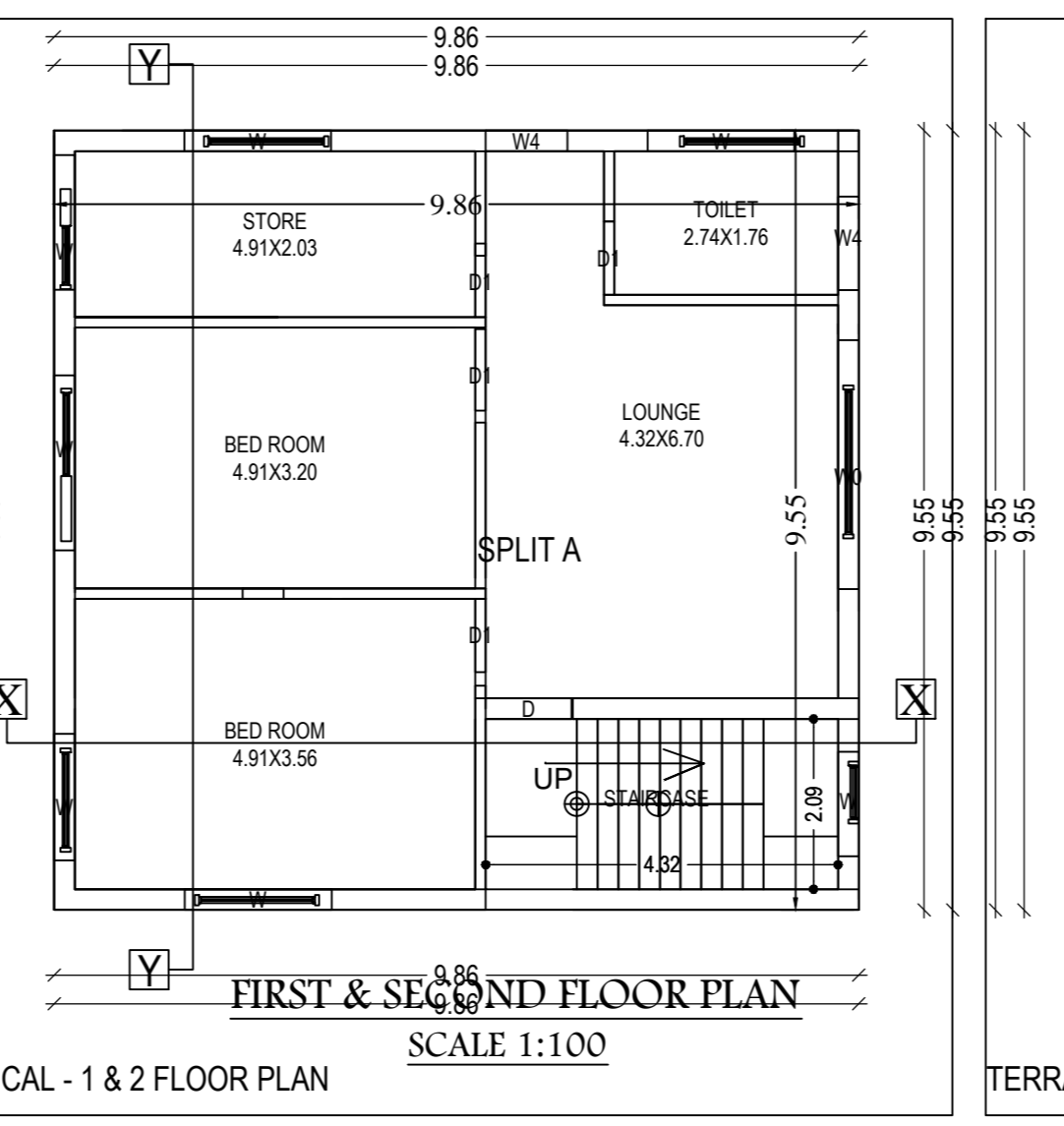
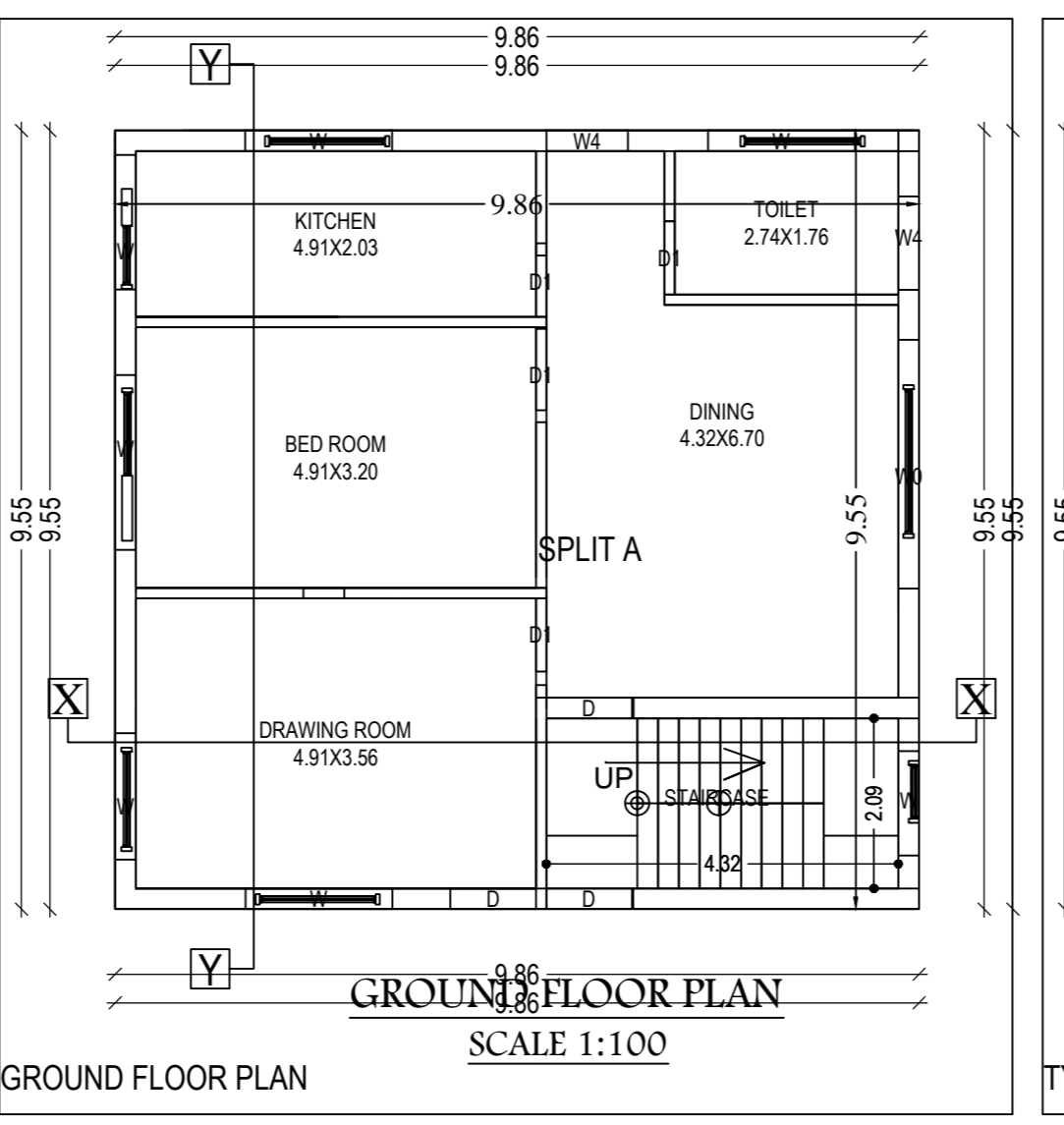
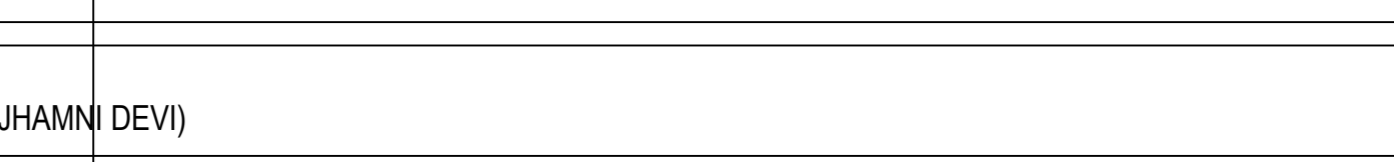
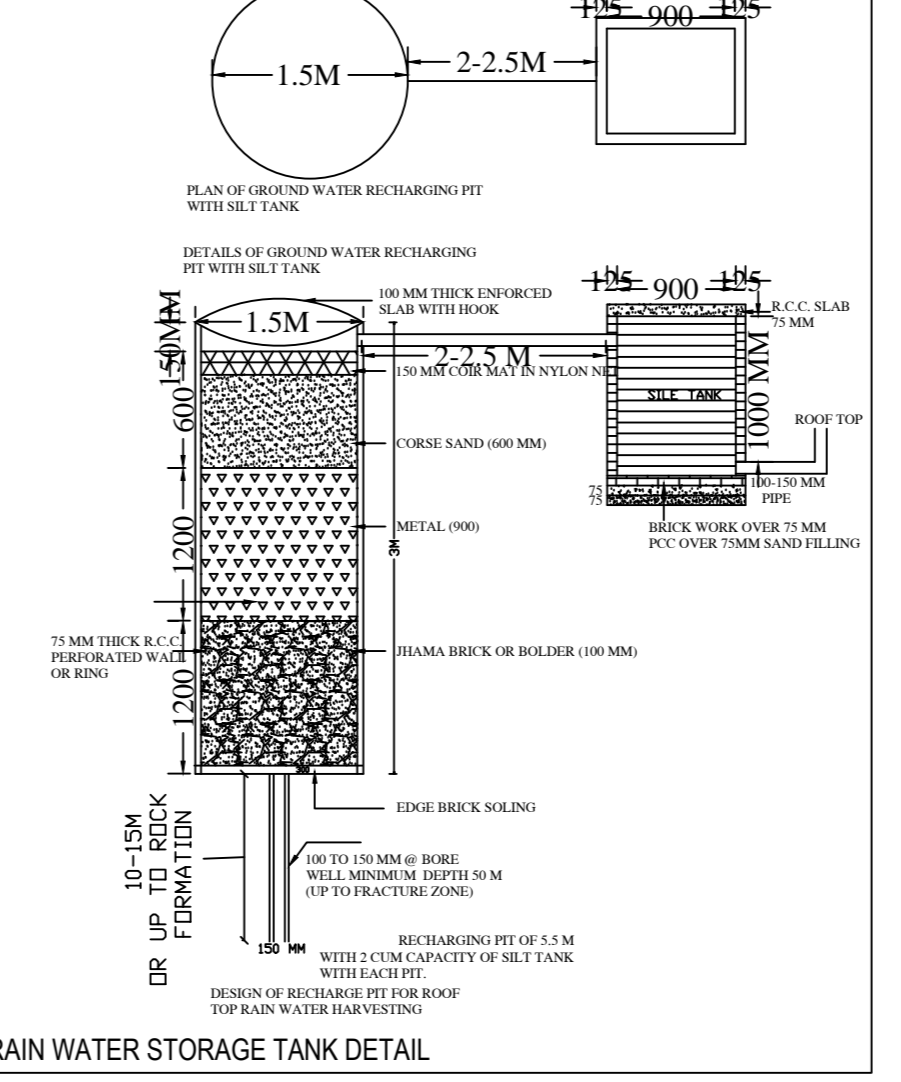
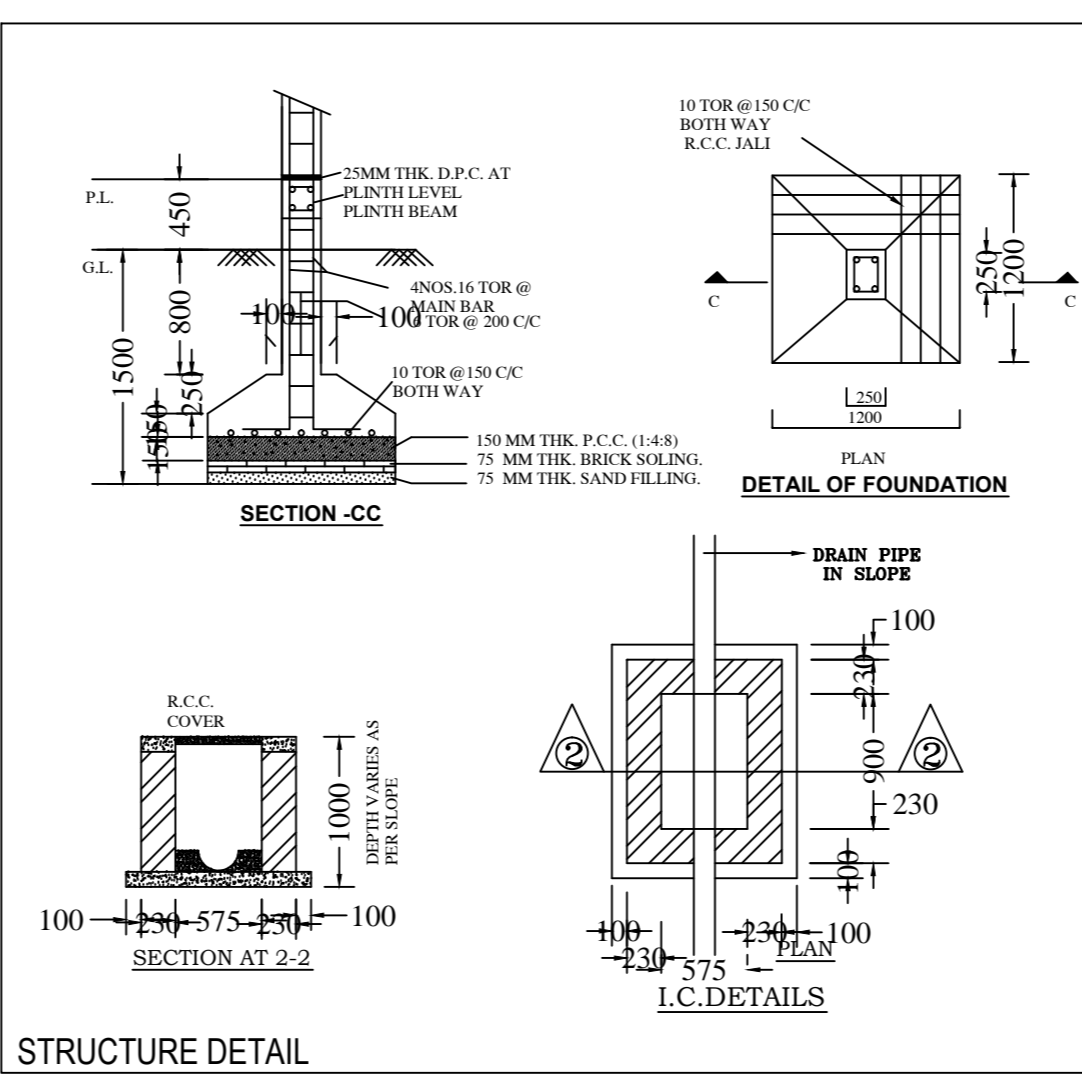
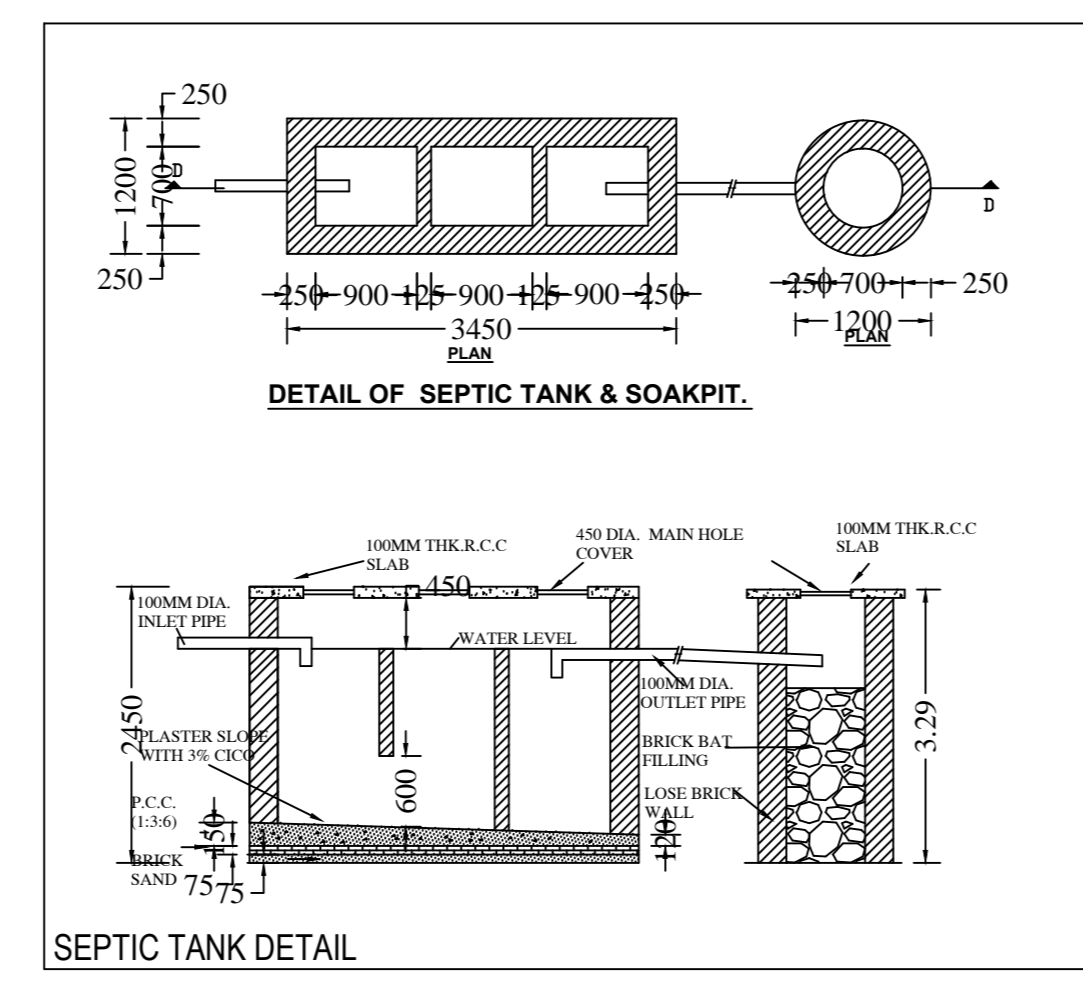
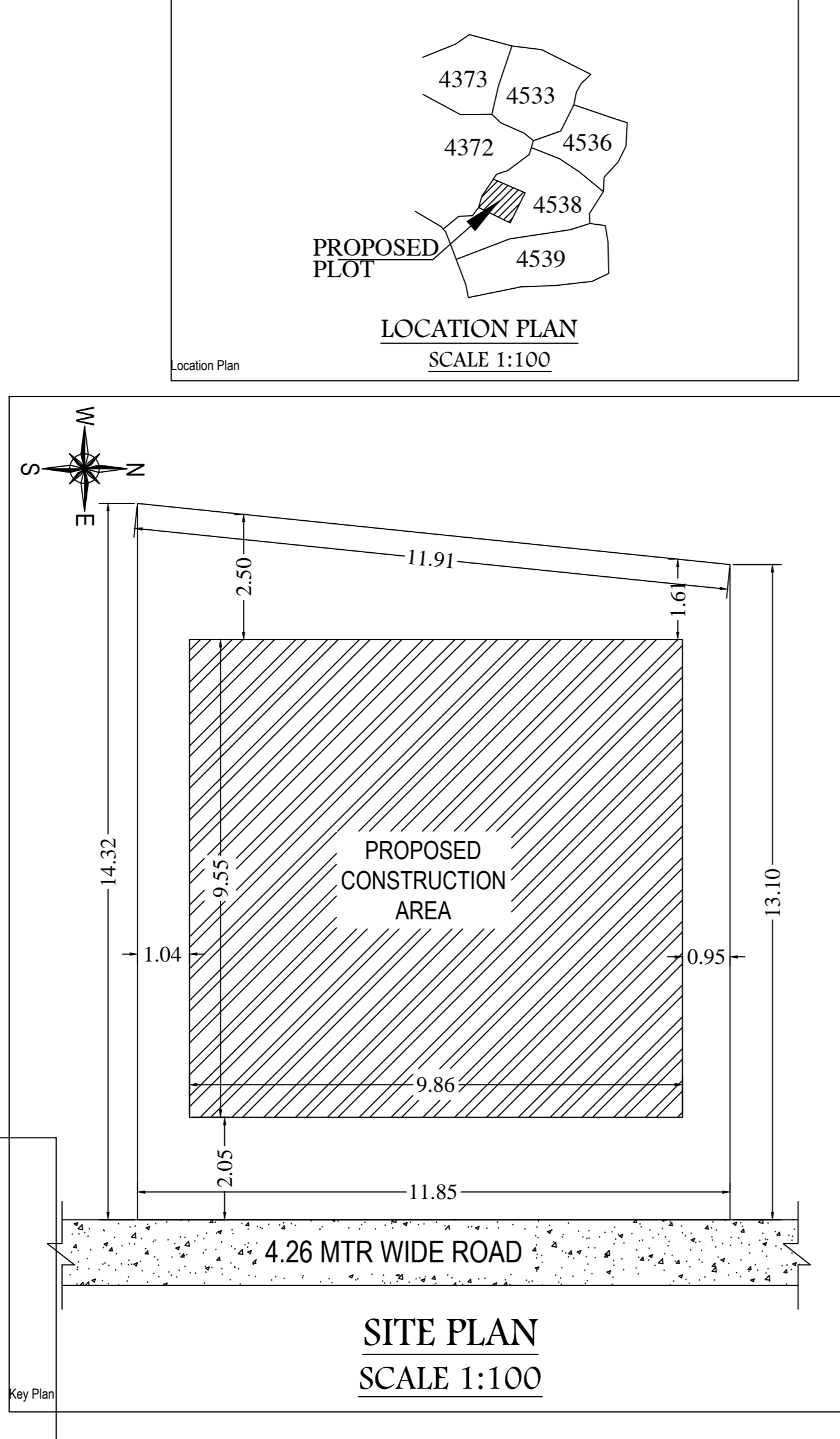
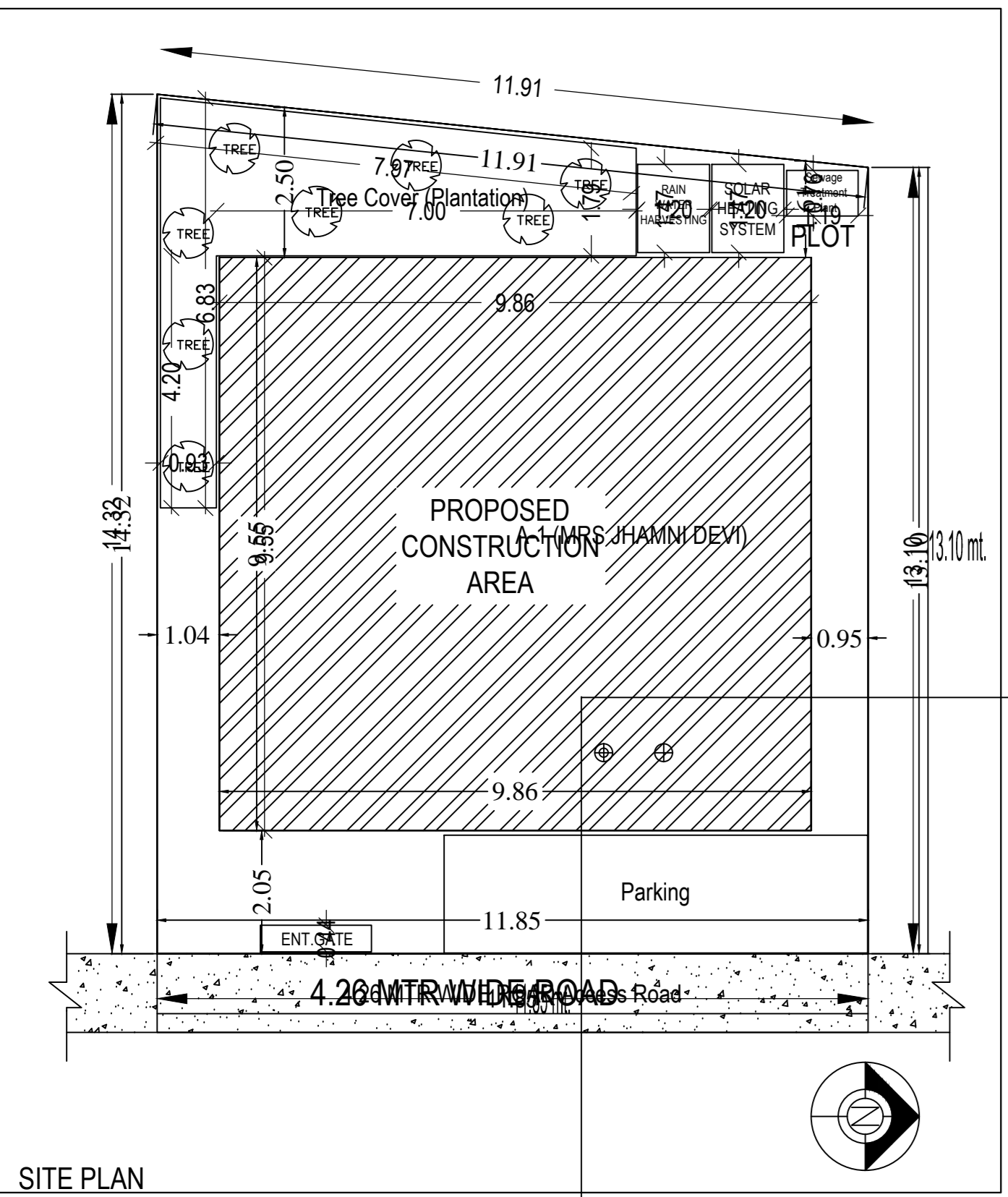

LAND DETAILS

PROPOSED RESIDENTIAL BUILDING PLAN OF
MRS JHAMNI DEVI
W/O. MR LAKHAN SAW
PLOT NO. - 4568, KHATA NO.- 618
VILLAGE - KODARMA
WARD NO- 14, THANA NO - 333
DISTRICT. - KODARMA
STATE -- JHARKHAND.

Applicant's Signature: _____ SIGNATURE OF LIC. ENGINEER _____

| Building :A (MRS JHAMNI DEVI) | | | | |
|--------------------------------|------------------------------|----------------------------|-------------------------|------------|
| Floor Name | Total Built Up Area (Sq.mt.) | Proposed FAR Area (Sq.mt.) | Total FAR Area (Sq.mt.) | Tnmt (No.) |
| Ground Floor | 94.16 | 94.16 | 94.16 | 01 |
| First Floor | 94.16 | 94.16 | 94.16 | 00 |
| Second Floor | 94.16 | 94.16 | 94.16 | 00 |
| Terrace Floor | 0.00 | 0.00 | 0.00 | 00 |
| Total | 282.48 | 282.48 | 282.48 | 01 |
| Total Number of Same Buildings | 1 | | | |
| Total | 282.48 | 282.48 | 282.48 | 01 |

| SCHEDULE OF JOINERY: | | | | |
|----------------------|------|--------|--------|-----|
| BUILDING NAME | NAME | LENGTH | HEIGHT | NOS |
| A (MRS JHAMNI DEVI) | D1 | 0.90 | 2.13 | 09 |
| A (MRS JHAMNI DEVI) | D1 | 1.00 | 2.13 | 03 |
| A (MRS JHAMNI DEVI) | D | 1.05 | 2.13 | 05 |
| Total | - | - | - | 17 |

| SCHEDULE OF JOINERY: | | | | |
|----------------------|------|--------|--------|-----|
| BUILDING NAME | NAME | LENGTH | HEIGHT | NOS |
| A (MRS JHAMNI DEVI) | W4 | 1.00 | 2.70 | 03 |
| A (MRS JHAMNI DEVI) | W4 | 1.15 | 2.70 | 03 |
| A (MRS JHAMNI DEVI) | W | 1.28 | 2.70 | 03 |
| A (MRS JHAMNI DEVI) | W | 1.55 | 2.70 | 03 |
| A (MRS JHAMNI DEVI) | W | 1.65 | 2.70 | 03 |
| A (MRS JHAMNI DEVI) | W | 1.80 | 2.70 | 09 |
| A (MRS JHAMNI DEVI) | W | 2.15 | 2.70 | 03 |
| A (MRS JHAMNI DEVI) | W0 | 3.05 | 2.70 | 03 |
| Total | - | - | - | 30 |

| UnitBUA Table for Building :A (MRS JHAMNI DEVI) | | | | | | |
|---|---------|--------------|--------------|-------------|--------------|-----------------|
| FLOOR | Name | UnitBUA Type | UnitBUA Area | Carpet Area | No. of Rooms | No. of Tenement |
| GROUND FLOOR PLAN | SPLIT A | FLAT | 148.32 | 148.19 | 5 | 1 |
| Total | - | - | 148.32 | 148.19 | 15 | 1 |