

Project Title :

PROPOSED BUILDING PLAN FOR (1) SRI. UMESH KUMAR RANA, (2) SRI. DEEPAK KUMAR RANA, S/O - LATE .RAM LAKHAN RANA. MAUZA-KDOERMAA, WARD NO- 08 . P.S-KODERMA .P.S NO- 333 . KHATA NO:- 92 . PLOT NO:- 4398,4399,4400,4401,4491 . DISTT- KODERMA (JHARAKHAND)

DATE	14-08-2021
SHEET NO.	1

Proposal Basic Information	
Proposal File No.	KONPC/BI/0021/W08/2021
Owner Name	1.SRI UMESH KR RANA 2. SRI DEEPAK RANA
Khata No	92
Plot No	4398,4399,4400,4401,4491
Village Name	Kodarma
Use	Residential
SubUse	Bungalow/ Dwelling / Non Apartment

Building :AA (UMESH KUMAR RANA DEEPAK KUMAR RANA)

Floor Name	Total Built Up Area (Sq.mt.)	Proposed FAR Area (Sq.mt.) Resi.	Total FAR Area (Sq.mt.)	Total Consumed Additional FAR Area (Sq.mt.)	Tnmt (No.)
Ground Floor	50.51	50.51	50.51	50.51	01
Terrace Floor	0.00	0.00	0.00	0.00	00
Total :	50.51	50.51	50.51	50.51	01
Total Number of Same Buildings :	1				
Total :	50.51	50.51	50.51	50.51	01

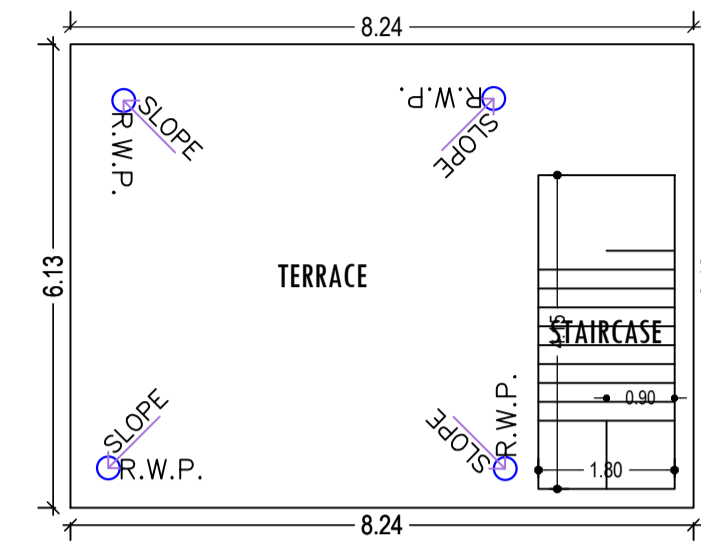
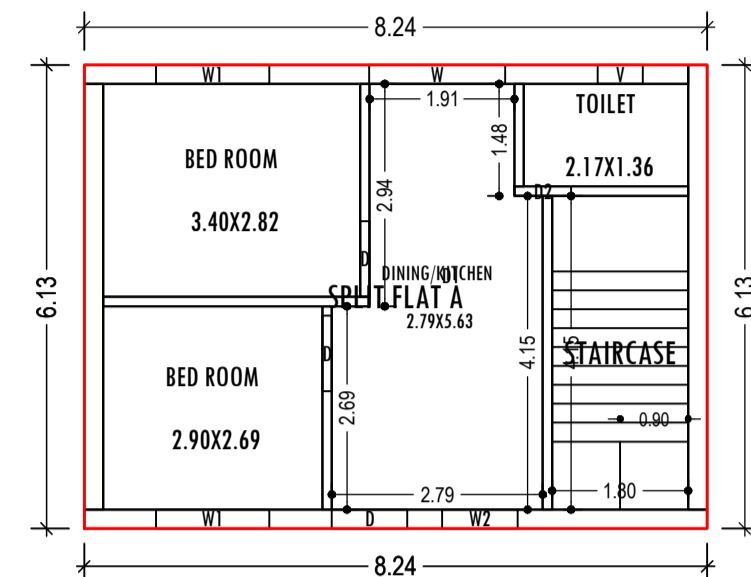
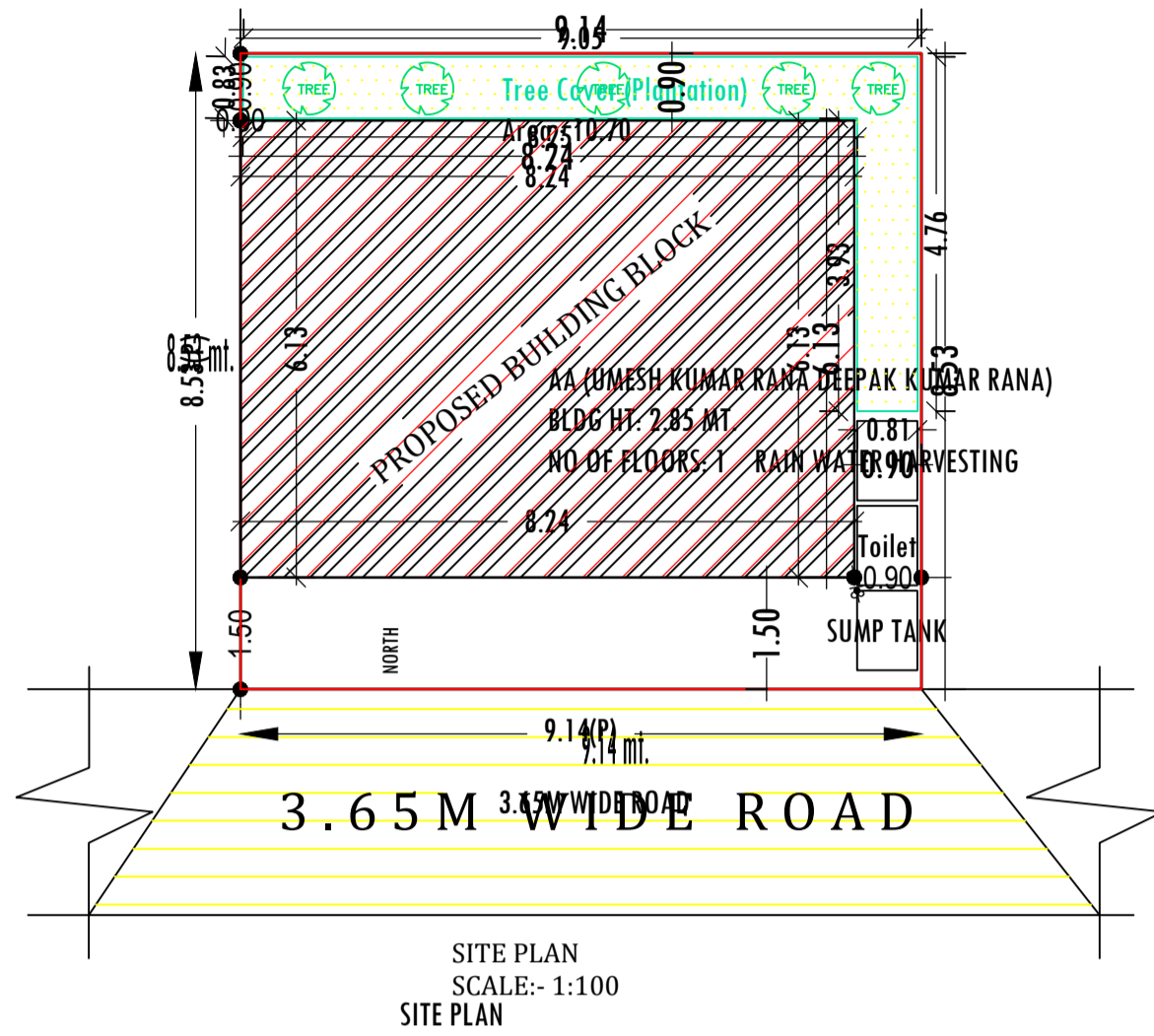

SCHEDULE OF DOOR:

BUILDING NAME	NAME	LENGTH	HEIGHT	NOS
AA (UMESH KUMAR RANA DEEPAK KUMAR RANA)	D2	0.75	2.13	01
AA (UMESH KUMAR RANA DEEPAK KUMAR RANA)	D	1.00	2.13	03

SCHEDULE OF WINDOW/VENTILATION:

BUILDING NAME	NAME	LENGTH	HEIGHT	NOS
AA (UMESH KUMAR RANA DEEPAK KUMAR RANA)	V	0.60	0.60	01
AA (UMESH KUMAR RANA DEEPAK KUMAR RANA)	W2	1.00	1.20	01
AA (UMESH KUMAR RANA DEEPAK KUMAR RANA)	W1	1.50	1.20	02
AA (UMESH KUMAR RANA DEEPAK KUMAR RANA)	W	1.80	1.20	01

AREA STATEMENT KODERMA NAGAR PANCHAYAT	VERSION NO.: 1.0.60 VERSION DATE: 16/10/2020
PROJECT DETAIL:	
Region: JHARKHAND URBAN	Plot Use: Residential
LOCAL BODIES	Plot SubUse: Bungalow/ Dwelling / Non Apartment
District: KODERMA	PlotNearby/ReligiousStructure: NA
Authority: KODERMA NAGAR PANCHAYAT	
Inward No: KONPC/BI/0021/W08/2021	Plot/SubPlot No: 4398,4399,4400,4401,4491
Application Type: General Proposal	North: Plot No. - VISHNU MONDAL
Project Type: Building Permission	South: Road Width - RASTA
Nature of Development: New	East: Road Width - P.C.C RASTA
Location of Development Area: Old Area	West: Plot No. - CHHOTU RANA
AREA DETAILS:	SQ.MT.
AREA OF PLOT (Minimum)	(A) 77.96
NET AREA OF PLOT(Gross Plot Area - Deduction from Gross Plot area)	(A-Deductions) 77.96
Deduction for Balance Plot Area(from Gross Plot Area)	
Common Plot	10.70
Total	10.70
BALANCE AREA OF PLOT(Net Plot Area - Recreational/Amenity space)	(A-Deductions) 67.26
PLOT AREA FOR COVERAGE(Net Plot Area)	(A-Deductions) 77.96
Plot Area for FAR (Net Plot Area + Road/Widening Area)	(A-Deductions) 77.96
COVERAGE CHECK	
Permissible Coverage area (70.00 %)	54.57
Proposed Coverage Area (64.79 %)	50.51
Total Prop. Coverage Area (64.79 %)	50.51
Balance coverage area (5.21 %)	4.06
FAR CHECK	
Perm. FAR Area (1.50)	116.94
Total Perm. FAR area	116.94
Residential FAR	50.51
Proposed FAR Area	50.51
Total Proposed FAR Area	50.51
Consumed FAR (Factor)	0.65
Balance FAR Area	66.43
BUILT UP AREA CHECK	
Total Proposed BuiltUp Area	50.51
ARCHITECT (Regd)	Amrendra Kumar
ENGINEER (Regd)	
SUPERVISOR (Regd)	
OWNER (Regd)	1.SRI UMESH KR RANA 2. SRI DEEPAK RANA
DEVELOPMENT AUTHORITY	LOCAL BODY

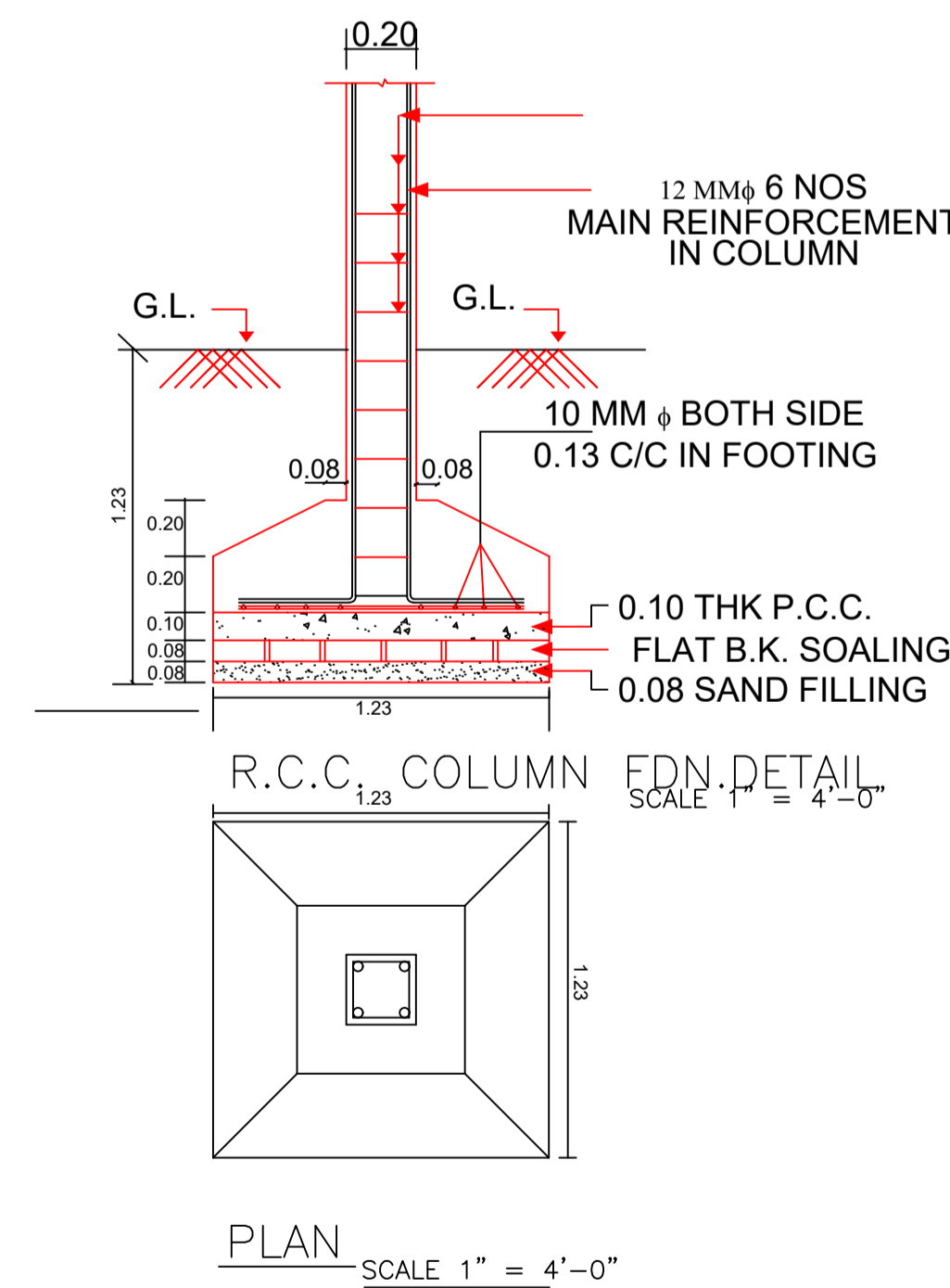
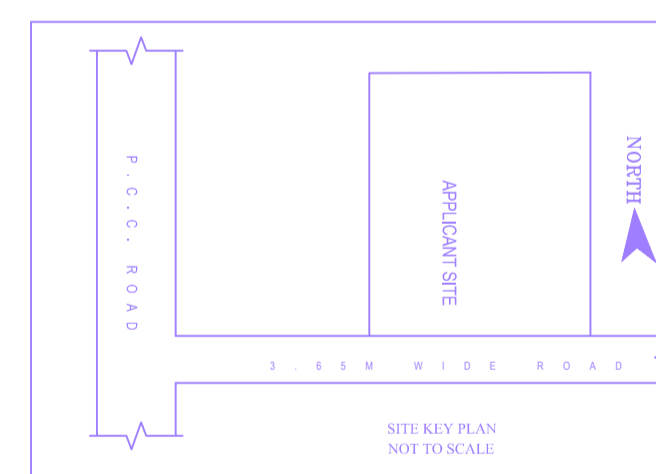
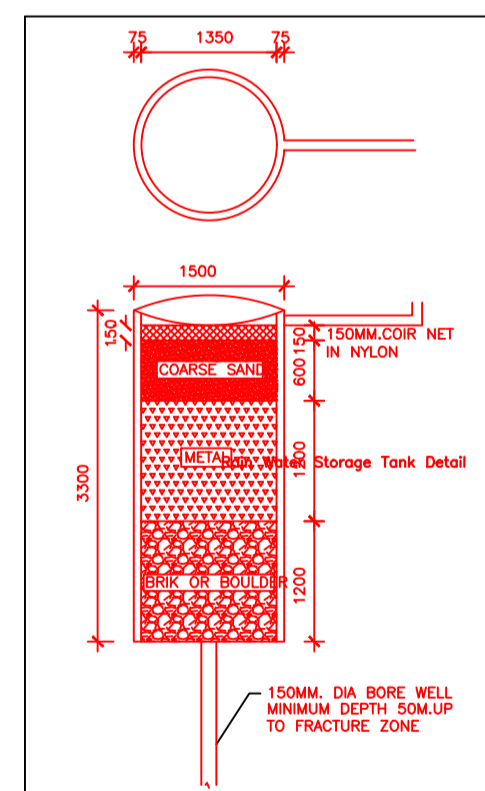
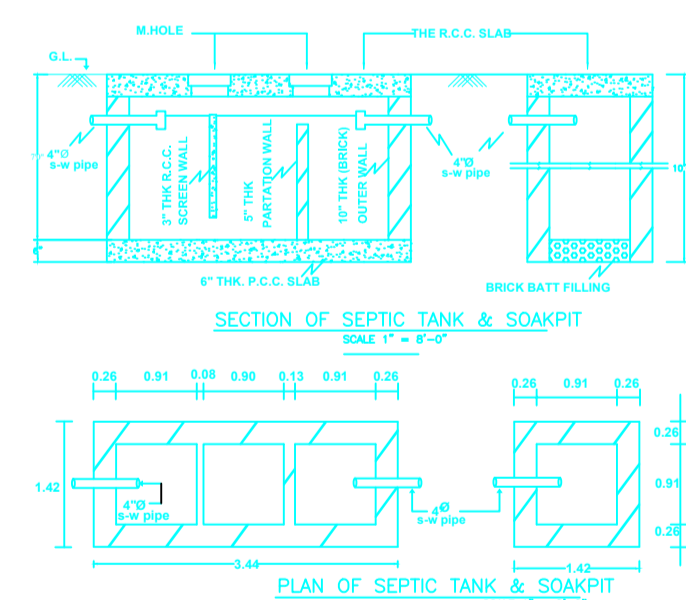
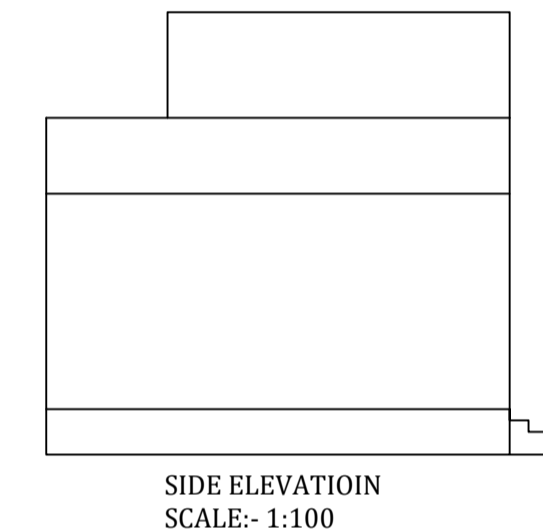
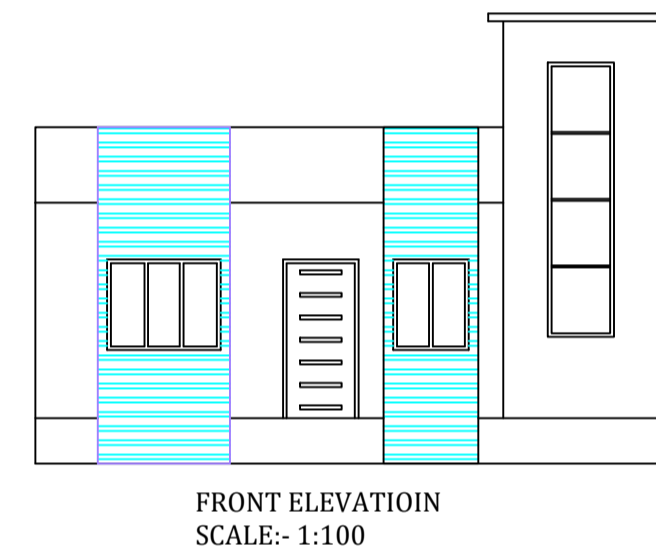
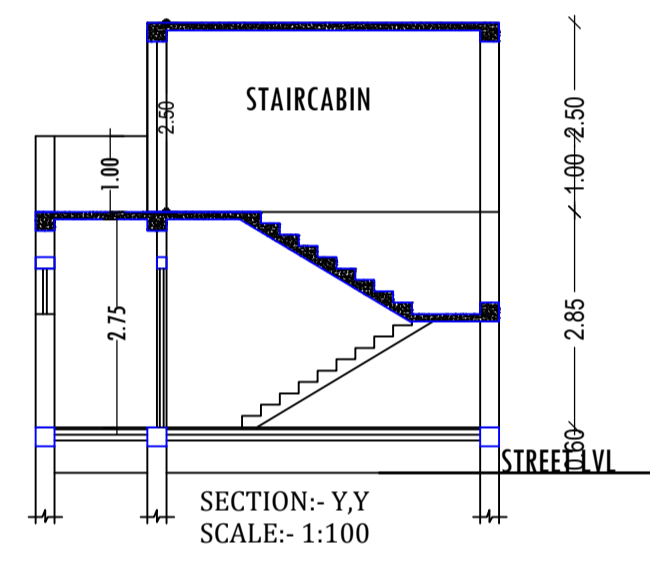
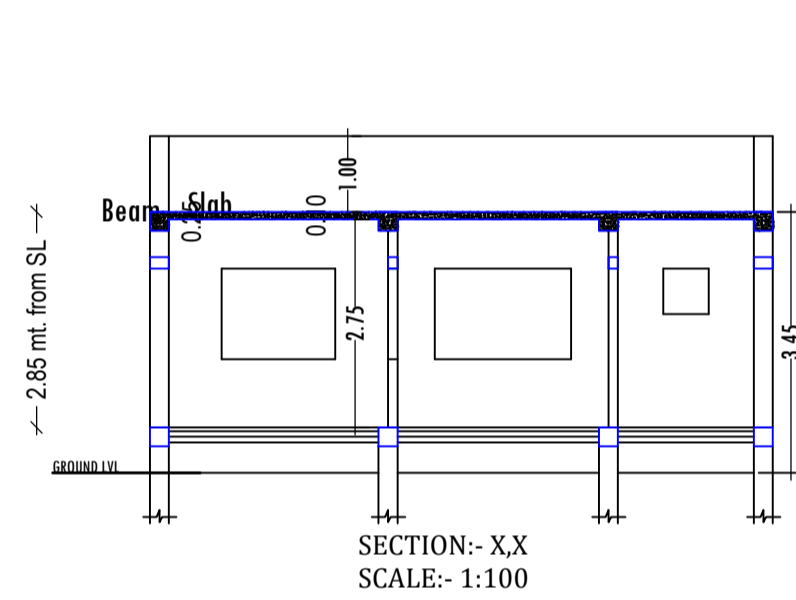

Buildingwise Floor FAR Details

Floor Name	Building Name		Total	
	AA (UMESH KUMAR RANA DEEPAK KUMAR RANA)	Proposed FAR Area (Sq.mt.)	Total Proposed Built Up Area (Sq.mt.)	Total FAR Area (Sq.mt.)
Ground Floor	50.51	50.51	50.51	50.51
Terrace Floor	0.00	0.00	0.00	0.00
Total :	50.51	50.51	50.51	50.51

Building USE/SUBUSE Details

Building Name	Building Use	Building SubUse	Building Structure
AA (UMESH KUMAR RANA DEEPAK KUMAR RANA)	Residential	Bungalow/ Dwelling / Non Apartment	Non-Highrise

FAR & Tenement Details (Table 4c-1)

Building	No. of Same Bldg	Total Built Up Area (Sq.mt.)	Proposed FAR Area (Sq.mt.) Resi.	Total FAR Area (Sq.mt.)	Total Consumed Additional FAR Area (Sq.mt.)	Tnmt (No.)
AA (UMESH KUMAR RANA DEEPAK KUMAR RANA)	1	50.51	50.51	50.51	50.51	01
Grand Total :	1	50.51	50.51	50.51	50.51	01

UnitBUA Table for Building :AA (UMESH KUMAR RANA DEEPAK KUMAR RANA)

FLOOR	Name	UnitBUA Type	UnitBUA Area	Carpet Area	No. of Rooms	No. of Tenement
GROUND FLOOR PLAN	SPLIT FLAT A	FLAT	36.11	34.00	4	1
Total:	-	-	36.11	34.00	4	1

COLOR INDEX	
PLOT BOUNDARY	Black
ABUTTING ROAD	Red
PROPOSED CONSTRUCTION	Green
COMMON PLOT	Blue
ROAD WIDENING AREA	Yellow
EXISTING (To be retained)	Light Blue
EXISTING (To be demolished)	Light Yellow

LTP NAME AND SIGNATURE	STRUCTURAL ENG'S NAME AND SIGNATURE	BUILDER NAME AND SIGNATURE	DIGITAL SIGNATURE
Amrendra Kumar KONPC/SUP/0022/2017			