

Proposal Basic Information	
Proposal File No.	KONPC/BP/0001/W02/2022
Owner Name	SRI.SHYAM SUNDER PRASAD
Khata No	360
Plot No	644
Village Name	Koderma
Use	Residential
SubUse	Bungalow/ Dwelling / Non Apartment

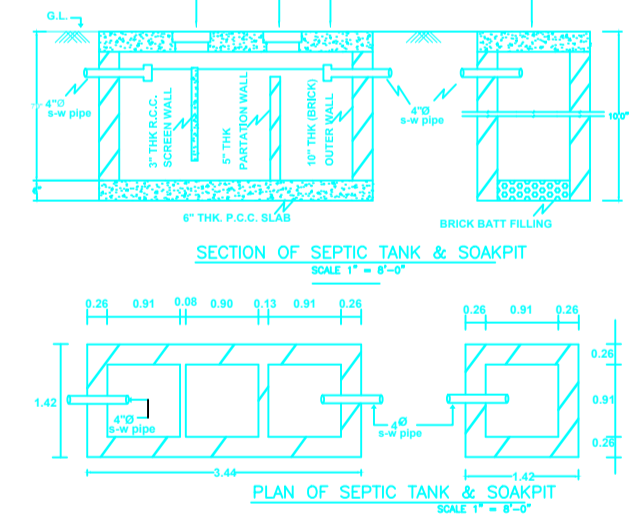
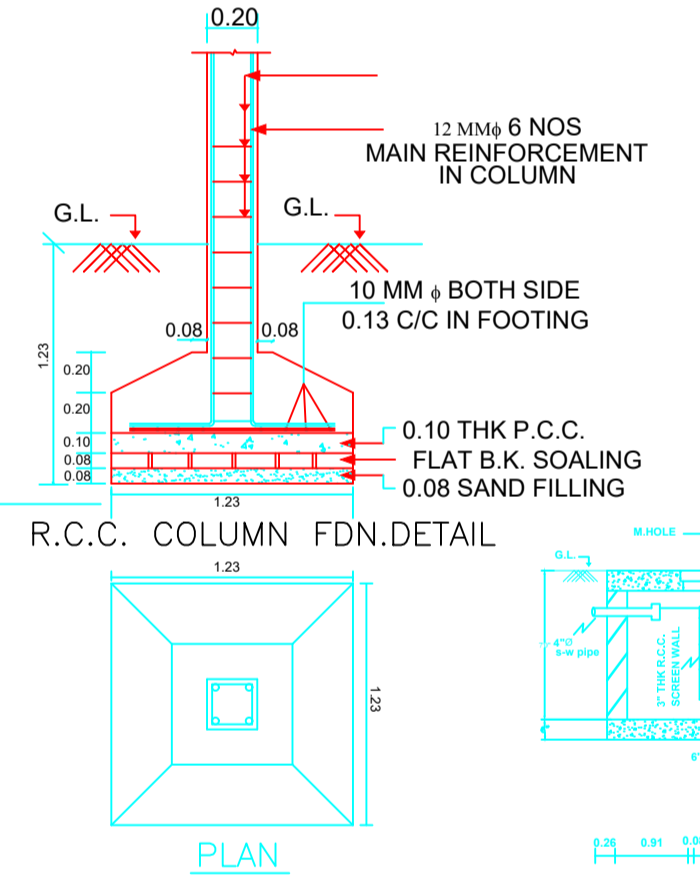
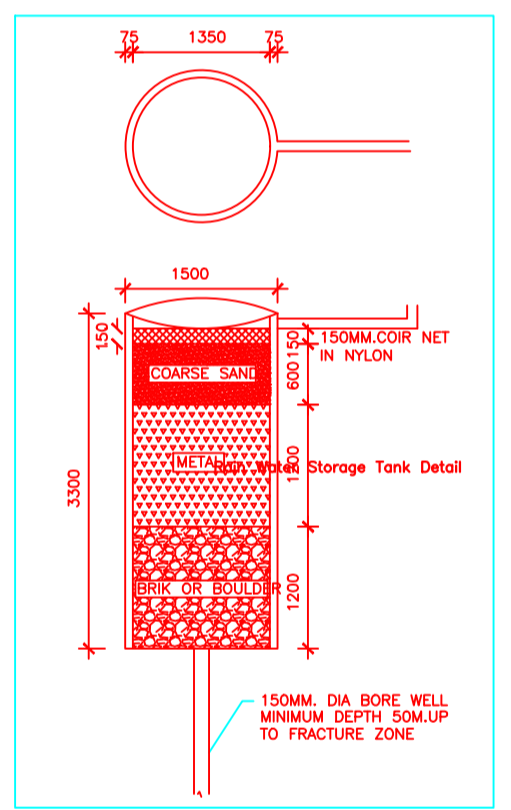
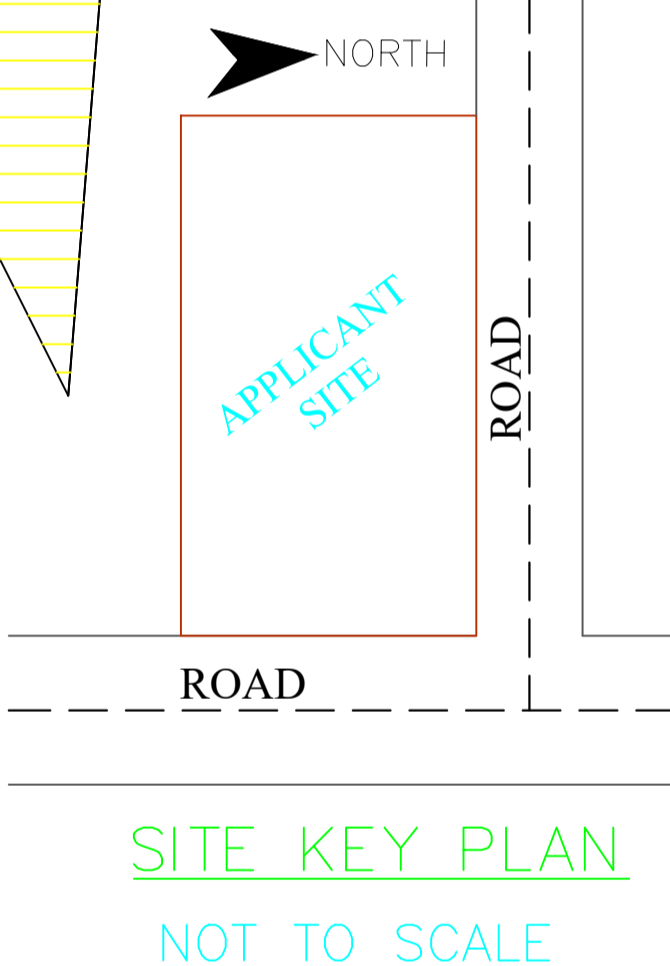
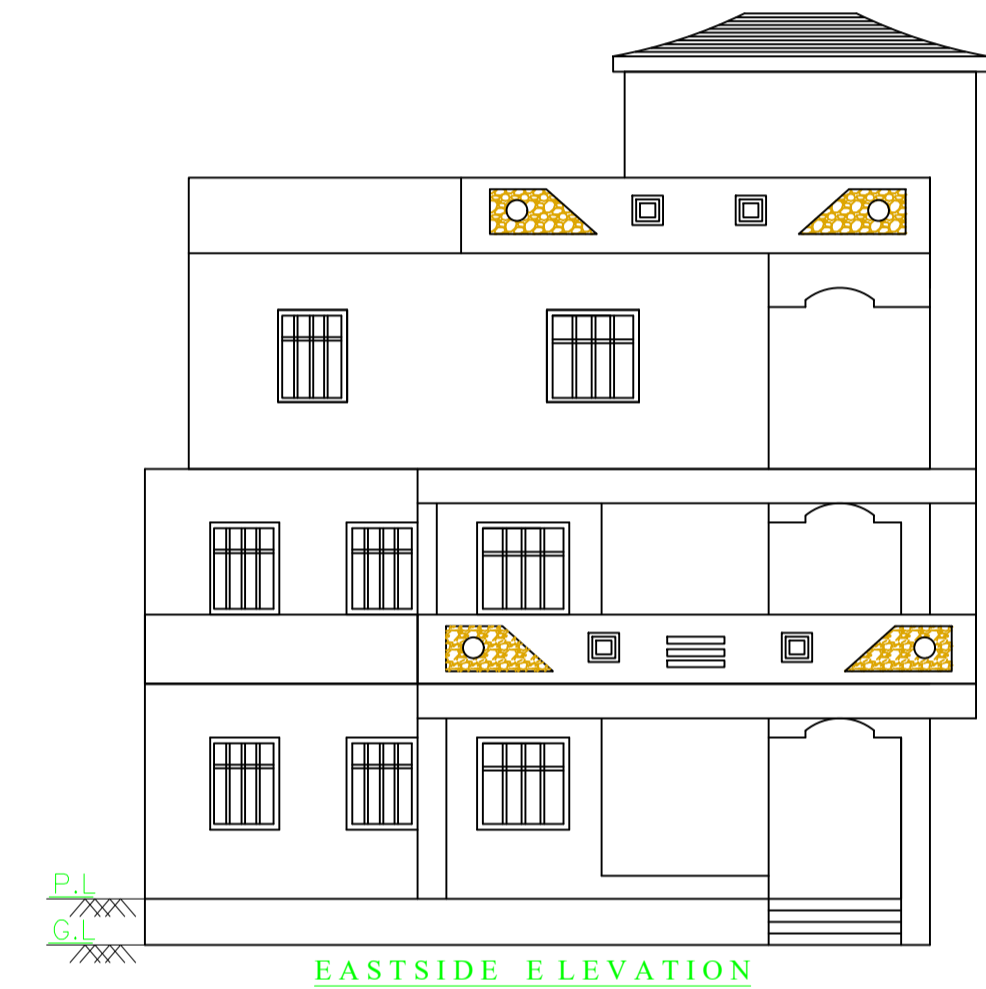
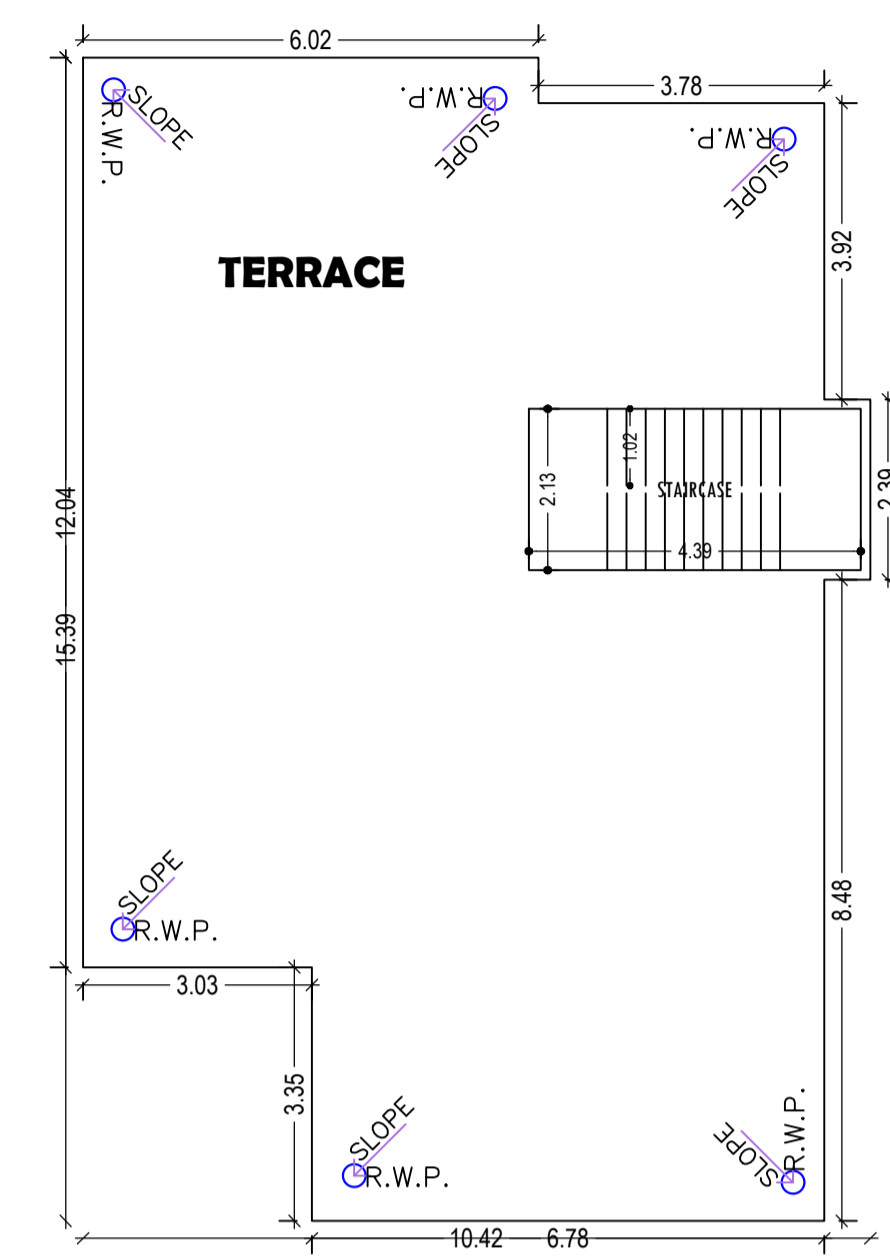
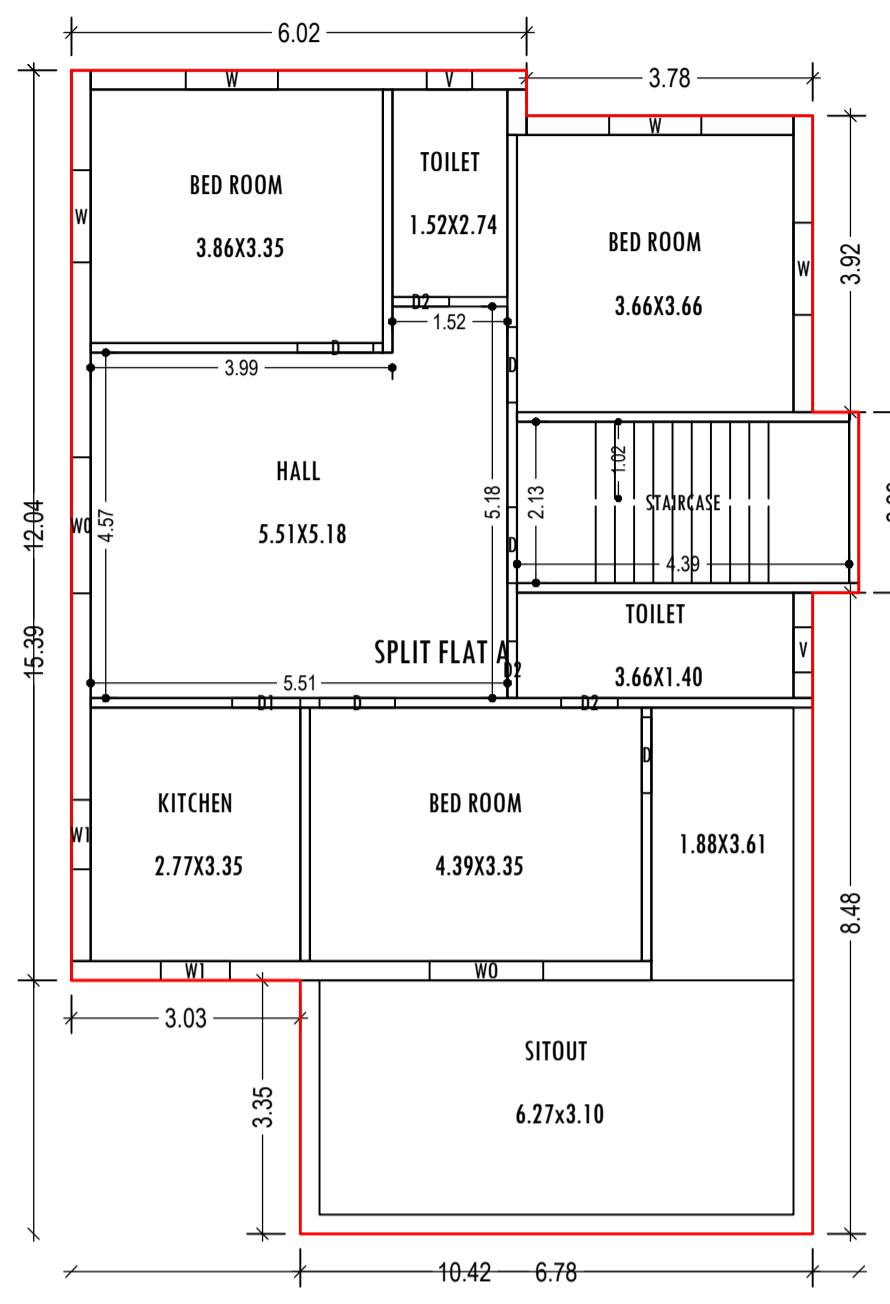
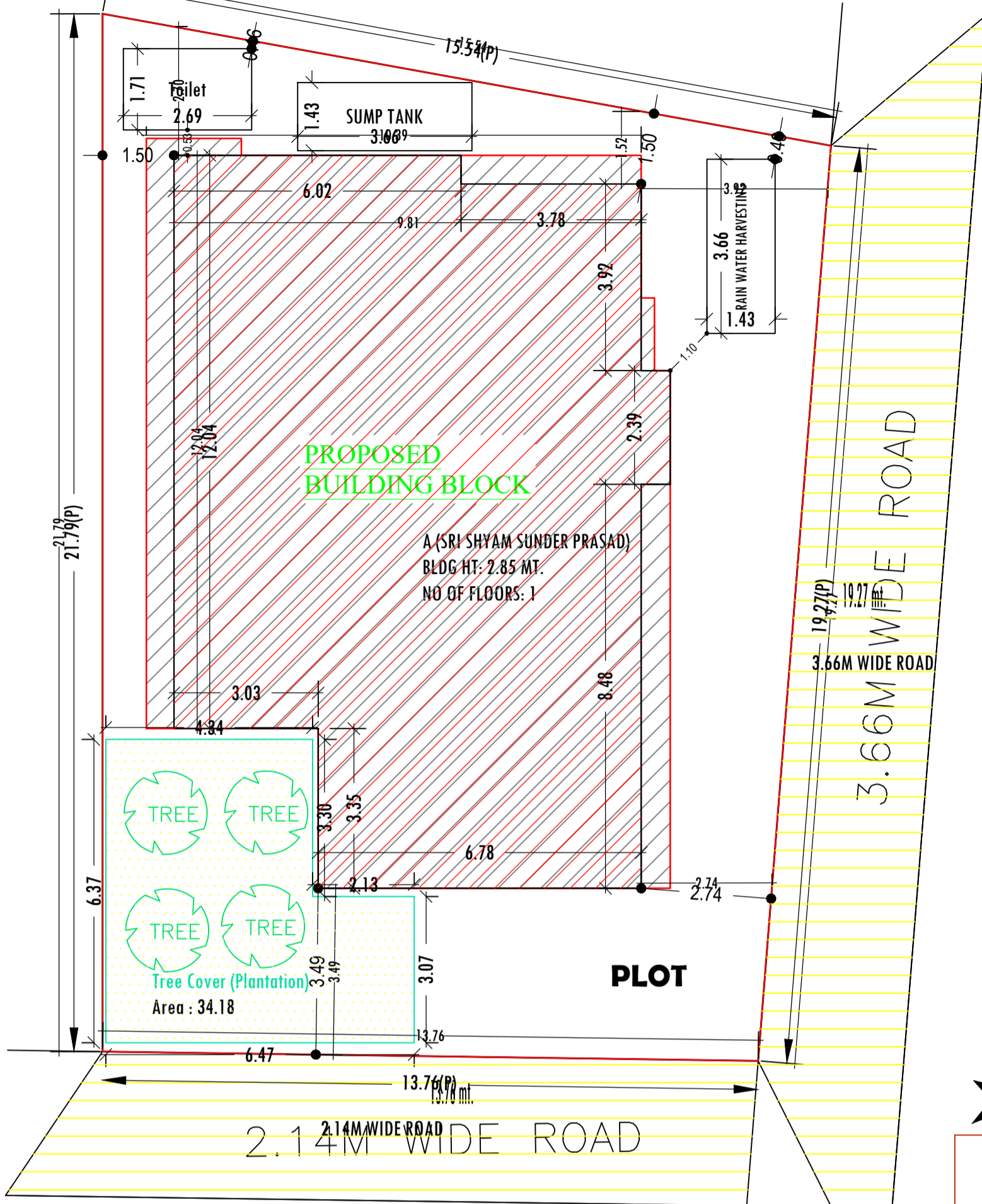

**Buildingwise Floor FAR Details**

Floor Name	Building Name A (SRI SHYAM SUNDER PRASAD)		Total	
	Proposed Built Up Area (Sq.mt.)	Proposed FAR Area (Sq.mt.)	Total Proposed Built Up Area (Sq.mt.)	Total FAR Area (Sq.mt.)
Second Floor	139.92	139.92	139.92	139.92
Terrace Floor	0.00	0.00	0.00	0.00
<b>Total :</b>	<b>139.92</b>	<b>139.92</b>	<b>139.92</b>	<b>139.92</b>

**FAR & Tenement Details (Table 4c-1)**

Building	No. of Same Bldg	Total Built Up Area (Sq.mt.)	Proposed FAR Area (Sq.mt.) Resi.	Total FAR Area (Sq.mt.)	Total Consumed Additional FAR Area (Sq.mt.)	Tnmt (No.)
A (SRI SHYAM SUNDER PRASAD)	1	139.92	139.92	139.92	139.92	01
<b>Grand Total :</b>	<b>1</b>	<b>139.92</b>	<b>139.92</b>	<b>139.92</b>	<b>139.92</b>	<b>01</b>

**AREA STATEMENT**  
 KODERMA NAGAR PANCHAYAT  
 PROJECT DETAIL:  
 Region: JHARKHAND URBAN LOCAL BODIES  
 District: KODERMA  
 Authority: KODERMA NAGAR PANCHAYAT  
 Inward No: KONPC/BP/0001/W02/2022  
 Application Type: General Proposal  
 Project Type: Building Permission  
 Nature of Development: New  
 Location of Development Area: Old Area

VERSION NO.: 1.0.61  
 VERSION DATE: 16/10/2020

Plot Use: Residential  
 Plot SubUse: Bungalow/ Dwelling / Non Apartment  
 PlotNearby/ReligiousStructure: NA  
 Plot/SubPlot No: 644  
 North: Road Width - 3.66M WIDE ROAD  
 South: Plot No. - SMT SANGITA KUMARI  
 East: Plot No. - 2.14M WIDE ROAD  
 West: Plot No. - MD NAVI MIYAN

AREA DETAILS:		SQ.MT.
AREA OF PLOT (Minimum)	(A)	298.90
NET AREA OF PLOT (Gross Plot Area - Deduction from Gross Plot area)	(A-Deductions)	298.90
Deduction for Balance Plot Area (from Gross Plot Area)		
Common Plot		34.18
Total		34.18
BALANCE AREA OF PLOT (Net Plot Area - Recreational/Amenity space)	(A-Deductions)	264.72
PLOT AREA FOR COVERAGE (Net Plot Area)	(A-Deductions)	298.90
Plot Area for FAR (Net Plot Area + Road Widening Area)	(A-Deductions)	298.90
COVERAGE CHECK		
Permissible Coverage area ( 60.00 % )		179.34
Proposed Coverage Area ( 46.81 % )		139.92
Total Prop. Coverage Area ( 46.81 % )		139.92
Balance coverage area ( 13.19 % )		39.42
FAR CHECK		
Perm. FAR Area ( 1.50 )		448.35
Total Perm. FAR area		448.35
Residential FAR		139.92
Proposed FAR Area		139.92
Total Proposed FAR Area		139.92
Consumed FAR (Factor)		0.47
Balance FAR Area		308.43
BUILT UP AREA CHECK		
Total Proposed BuiltUp Area		139.92
ARCHITECT (Regd)		Amrendra Kumar
ENGINEER (Regd)		
SUPERVISOR (Regd)		
OWNER (Regd)		SRI.SHYAM SUNDER PRASAD
DEVELOPMENT AUTHORITY		LOCAL BODY

**SCHEDULE OF DOOR:**

BUILDING NAME	NAME	LENGTH	HEIGHT	NOS
A (SRI SHYAM SUNDER PRASAD)	D2	0.75	2.10	03
A (SRI SHYAM SUNDER PRASAD)	D1	0.90	2.10	01
A (SRI SHYAM SUNDER PRASAD)	D	1.00	2.10	05

**SCHEDULE OF WINDOW/VENTILATION:**

BUILDING NAME	NAME	LENGTH	HEIGHT	NOS
A (SRI SHYAM SUNDER PRASAD)	V	0.60	0.60	02
A (SRI SHYAM SUNDER PRASAD)	W1	0.92	1.20	02
A (SRI SHYAM SUNDER PRASAD)	W	1.22	1.20	04
A (SRI SHYAM SUNDER PRASAD)	WO	1.50	1.20	01
A (SRI SHYAM SUNDER PRASAD)	WO	1.80	1.20	01

**Building -A (SRI SHYAM SUNDER PRASAD)**

Floor Name	Total Built Up Area (Sq.mt.)	Proposed FAR Area (Sq.mt.) Resi.	Total FAR Area (Sq.mt.)	Total Consumed Additional FAR Area (Sq.mt.)	Tnmt (No.)
Second Floor	139.92	139.92	139.92	139.92	01
Terrace Floor	0.00	0.00	0.00	0.00	00
<b>Total :</b>	<b>139.92</b>	<b>139.92</b>	<b>139.92</b>	<b>139.92</b>	<b>01</b>
<b>Total Number of Same Buildings :</b>	<b>1</b>				
<b>Total :</b>	<b>139.92</b>	<b>139.92</b>	<b>139.92</b>	<b>139.92</b>	<b>01</b>

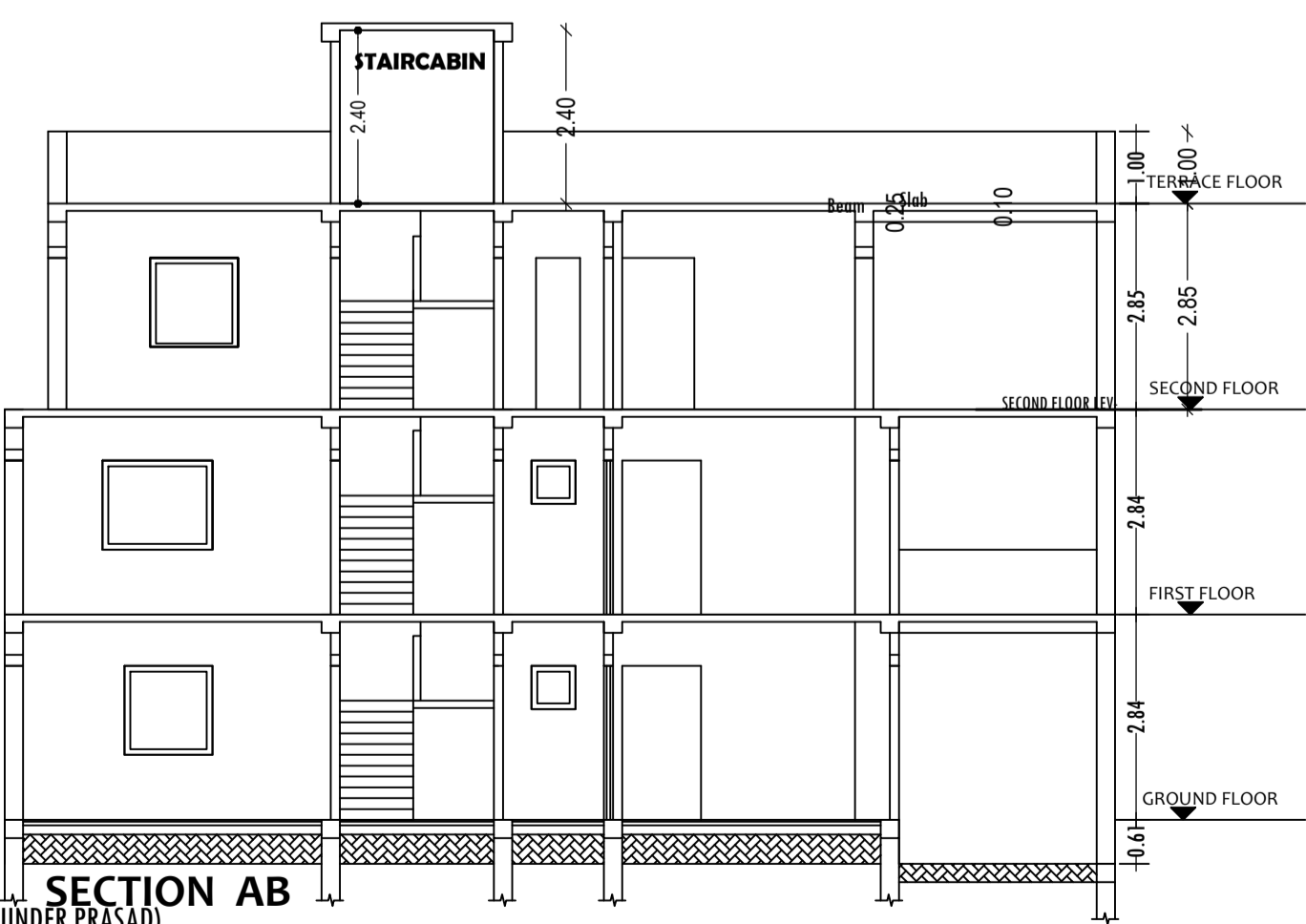
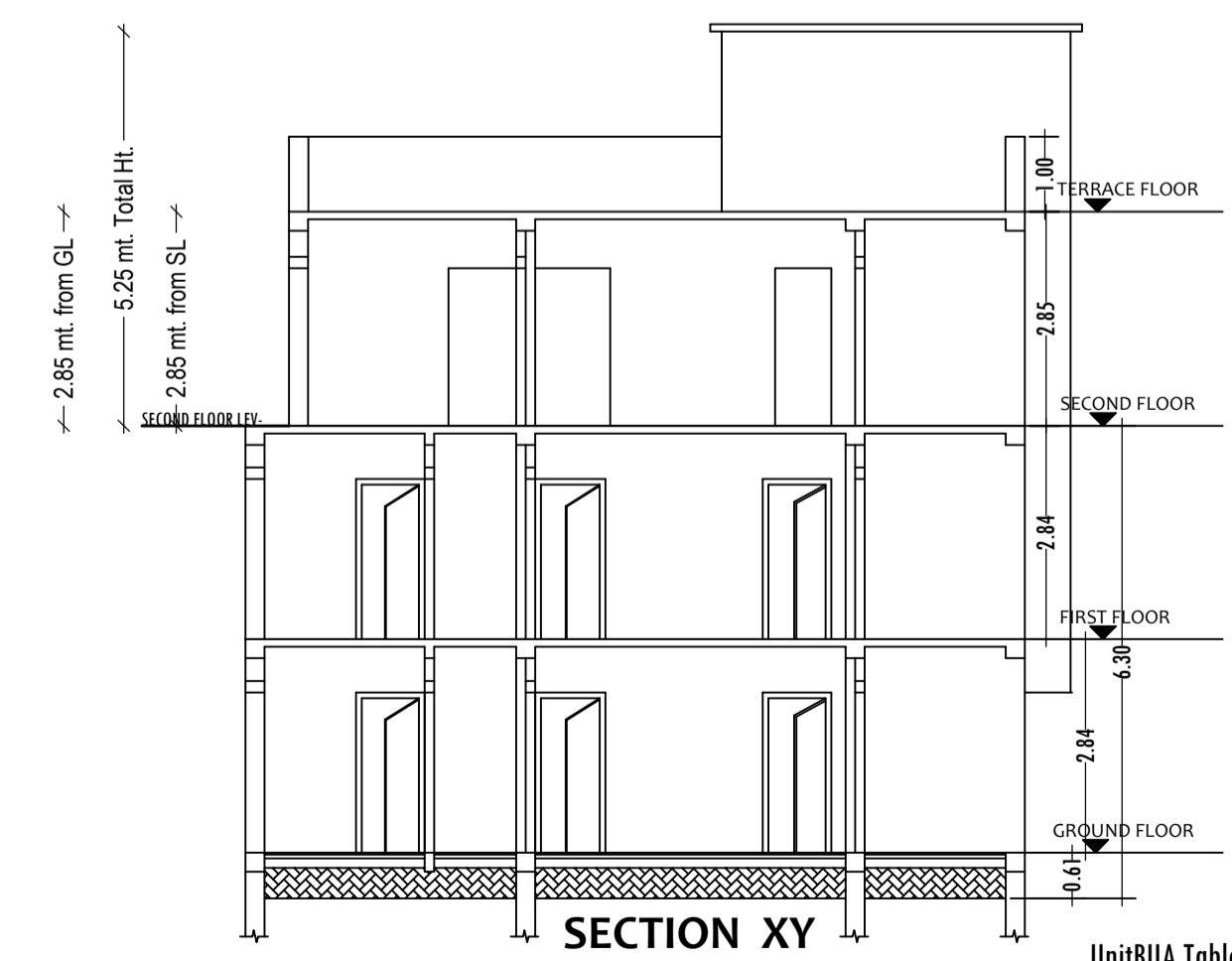

**UnitBUA Table for Building -A (SRI SHYAM SUNDER PRASAD)**

FLOOR	Name	UnitBUA Type	UnitBUA Area	Carpel Area	No. of Rooms	No. of Tenement
SECOND FLOOR PLAN	SPLIT FLAT A	FLAT	116.90	115.12	8	1
<b>Total:</b>	-	-	<b>116.90</b>	<b>115.12</b>	<b>8</b>	<b>1</b>

**Building USE/SUBUSE Details**

Building Name	Building Use	Building SubUse	Building Structure
A (SRI SHYAM SUNDER PRASAD)	Residential	Bungalow/ Dwelling / Non Apartment	Non-Highrise

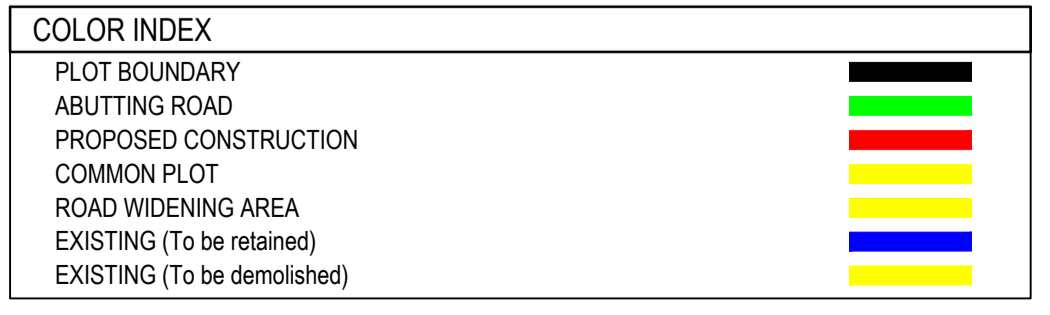

LTP NAME AND SIGNATURE	STRUCTURAL ENG'S NAME AND SIGNATURE	BUILDER NAME AND SIGNATURE	DIGITAL SIGNATURE
Amrendra Kumar KONPC/SUP/0002/2017			