

Proposal Basic Information

Proposal File No.	KONPC/BP/0002/W15/2022
Owner Name	DEWANTI DEVI
Khata No	665
Plot No	1874
Village Name	Kodarma
Use	Residential
SubUse	Bungalow/ Dwelling / Non Apartment

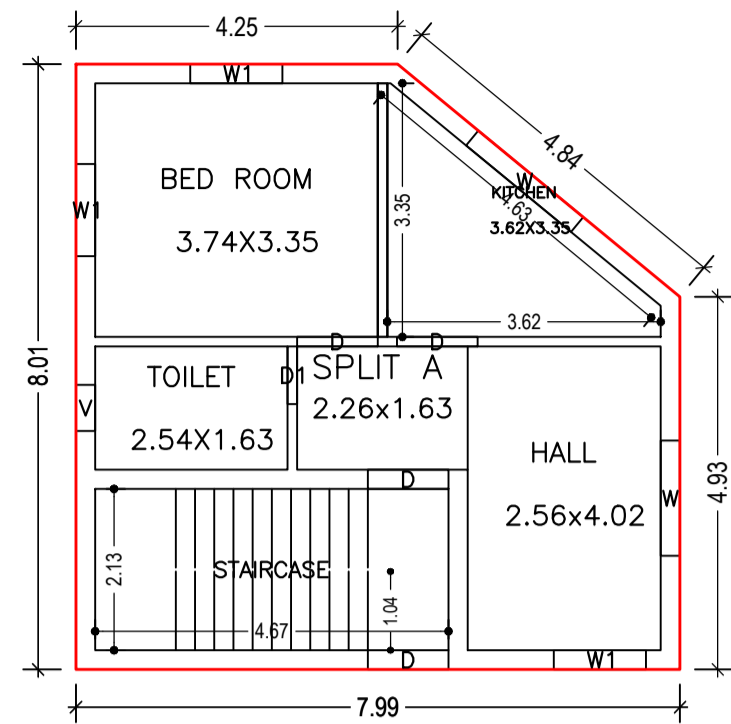

GROUND FLOOR PLAN (Proposed) (SCALE 1:100)

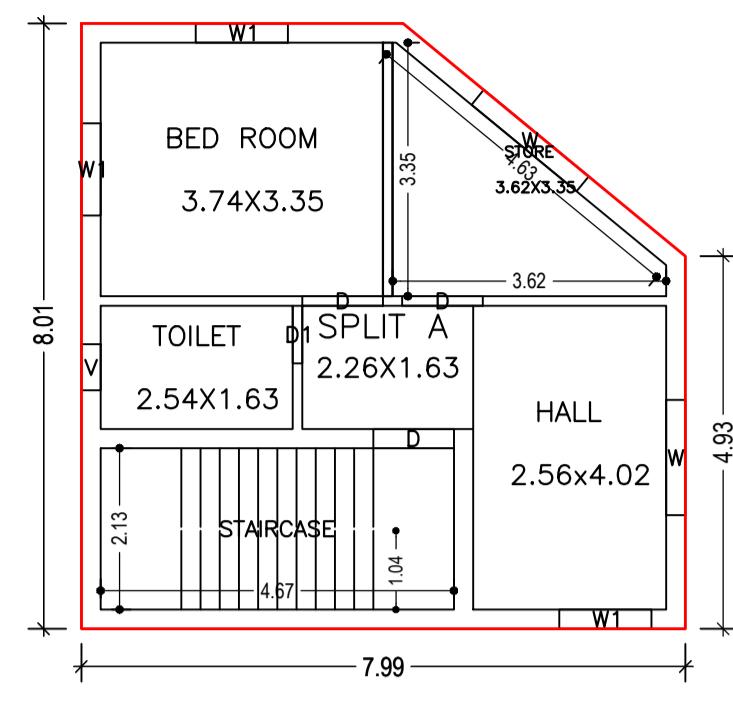

FIRST FLOOR PLAN (Proposed) (SCALE 1:100)

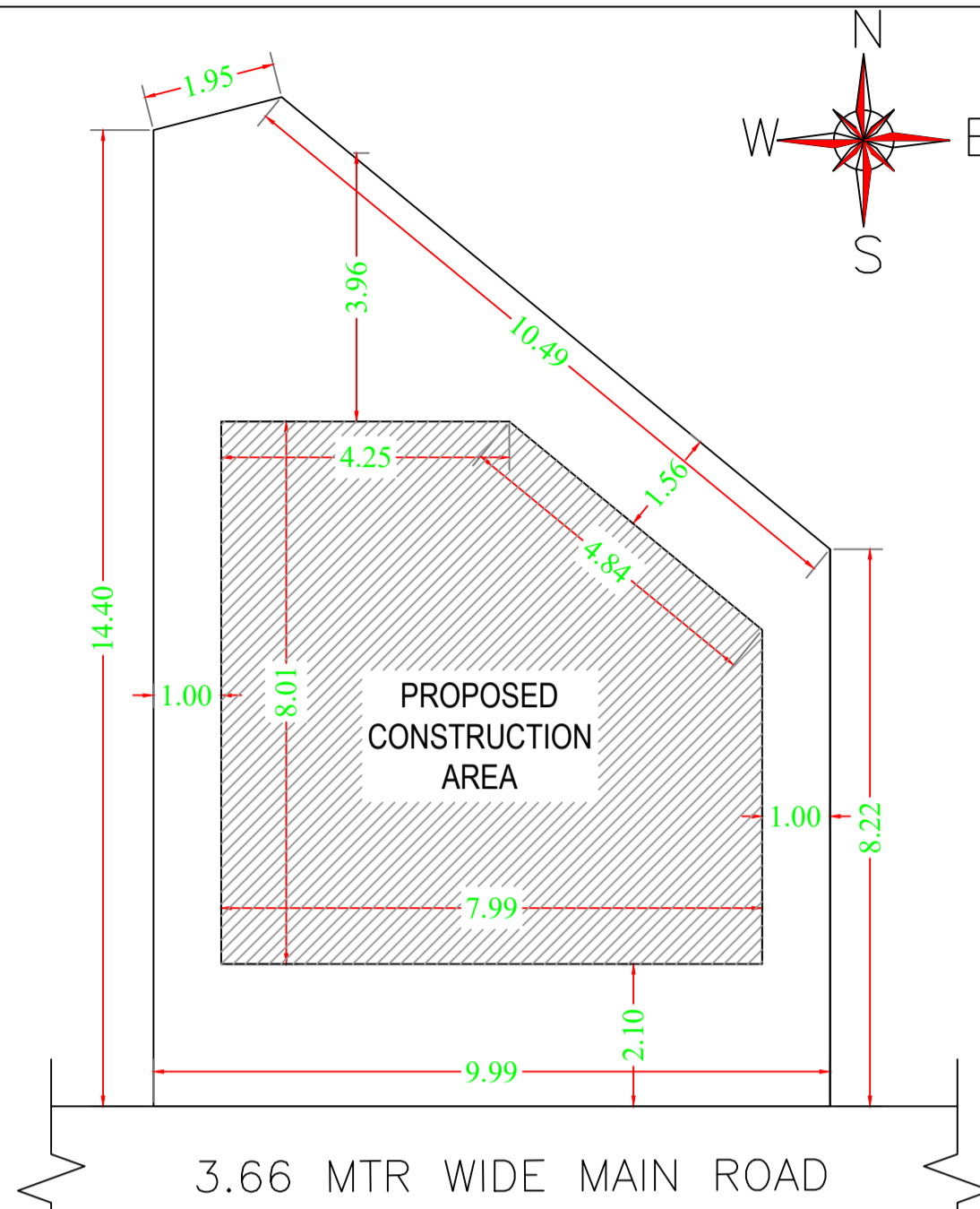

KEY PLAN SCALE 1:100

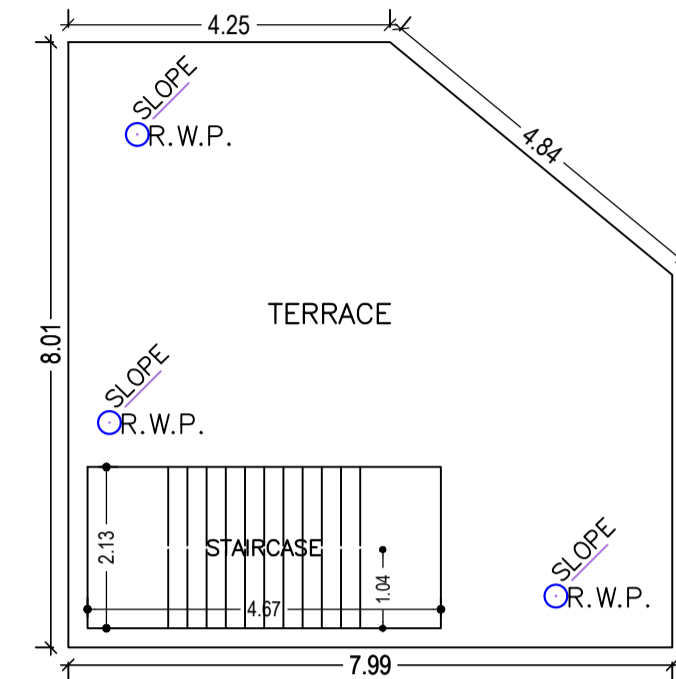

TERRACE FLOOR PLAN (SCALE 1:100)

Building USE/SUBUSE Details

Building Name	Building Use	Building SubUse	Building Structure
A (DEWANTI DEVI)	Residential	Bungalow/ Dwelling / Non Apartment	Non-Highrise

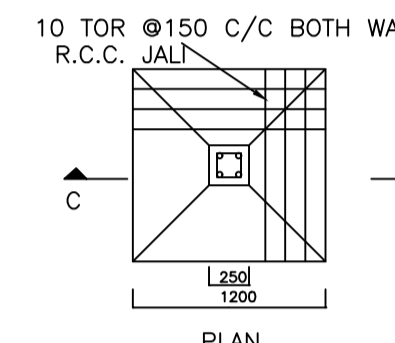

DETAIL OF FOUNDATION

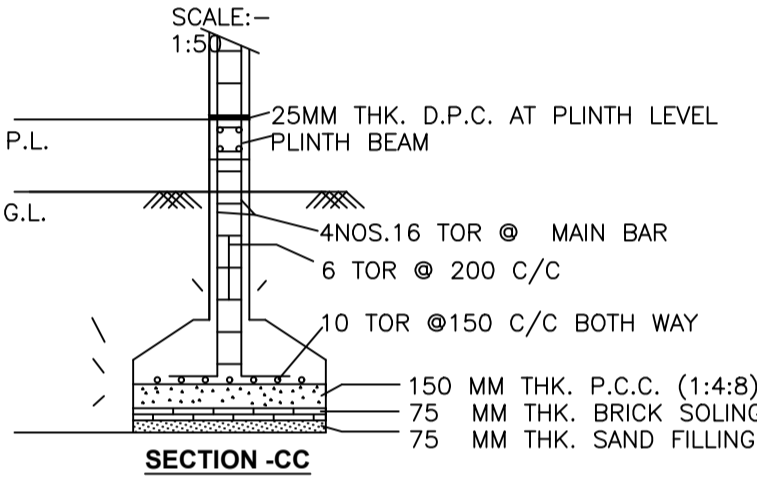

SECTION -CC

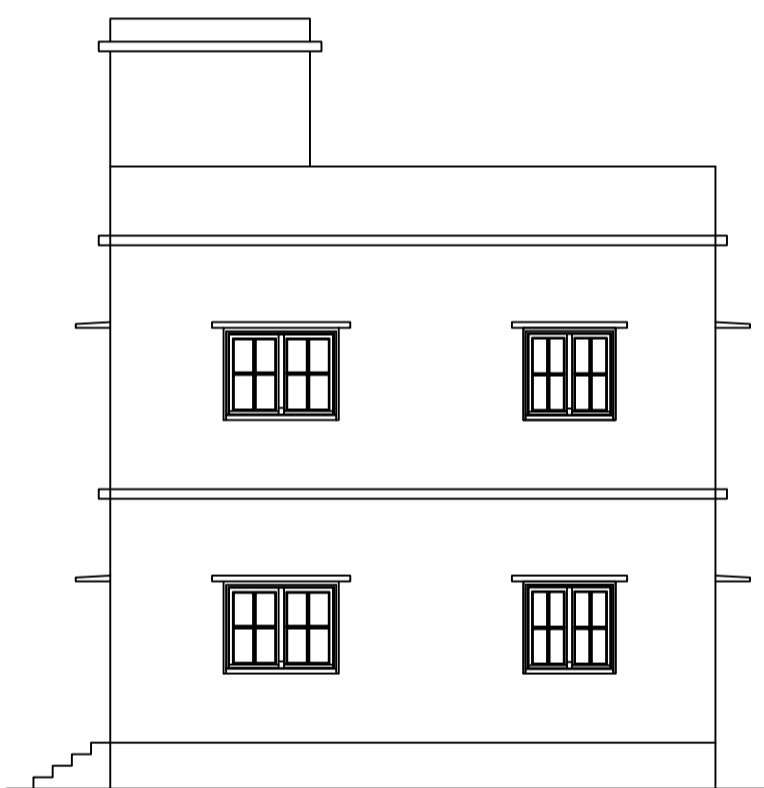

RIGHT SIDE ELEVATION SCALE 1:100

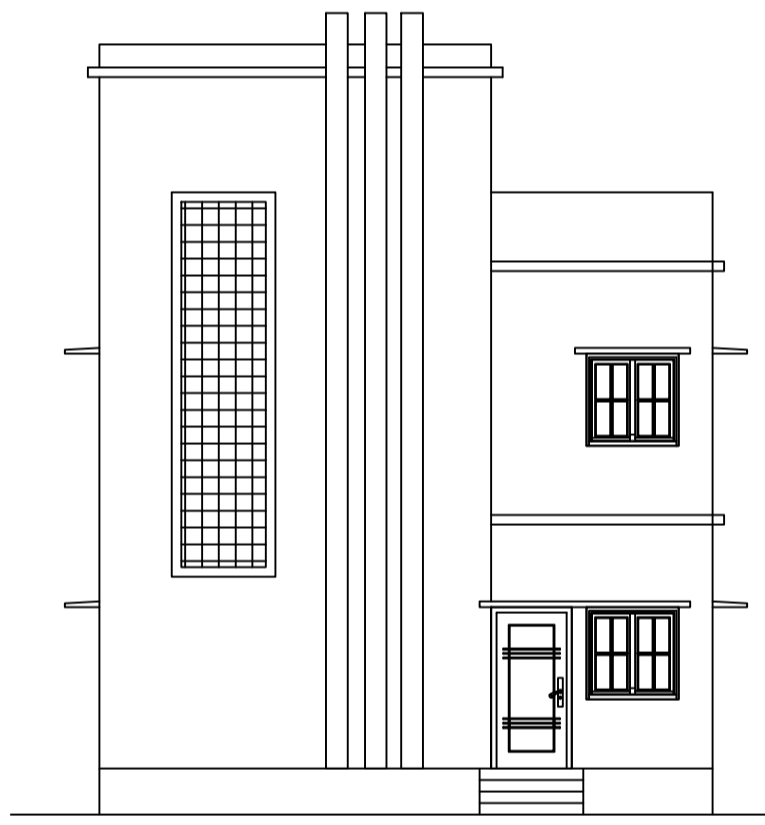

FRONT ELEVATION SCALE 1:100

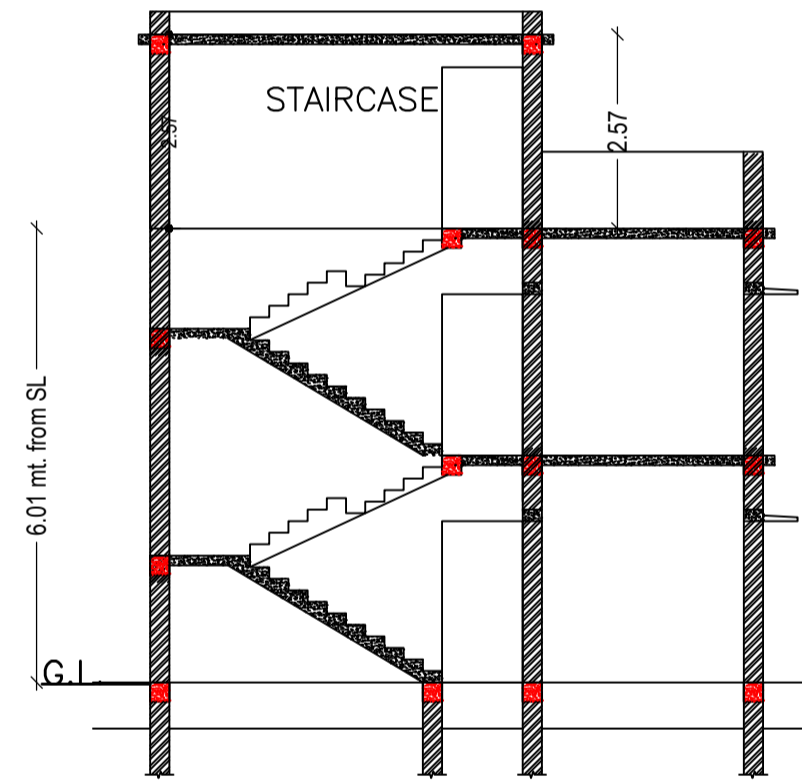

SECTION ON SCALE 1:100

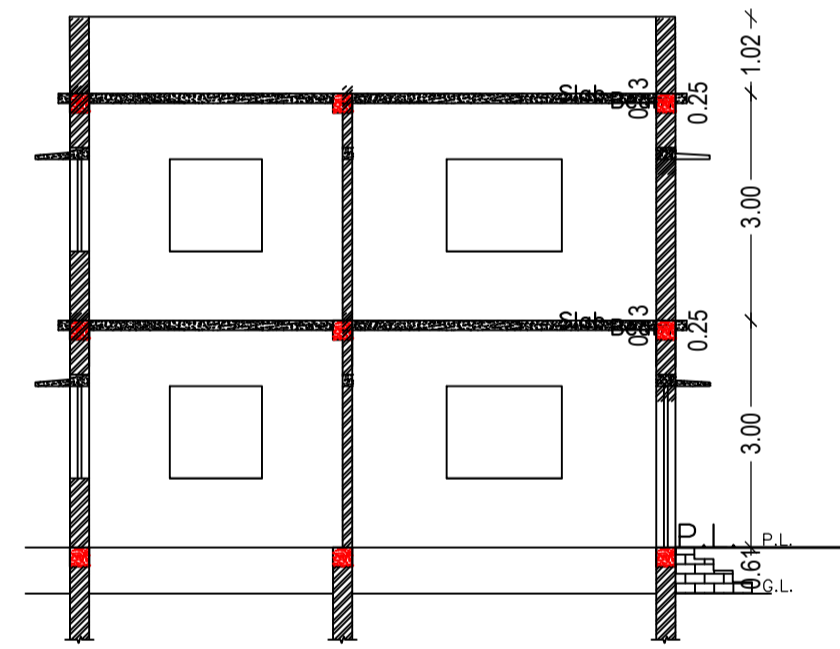

SECTION ON Y-Y SCALE 1:100

AREA STATEMENT KODERMA NAGAR PANCHAYAT	VERSION NO.: 1.0.62 VERSION DATE: 16/10/2020
PROJECT DETAIL:	
Region: JHARKHAND URBAN	Plot Use: Residential
Local Bodies: KODERMA	Plot SubUse: Bungalow/ Dwelling / Non Apartment
District: KODERMA	PlotNearbyReligiousStructure: NA
Authority: KODERMA NAGAR PANCHAYAT	Plot/SubPlot No: 1874
Inward No: KONPC/BP/0002/W15/2022	North: Road Width - 3.66 MTR WIDE MAIN ROAD
Application Type: General Proposal	South: Plot No. - PLOT NO-1872
Project Type: Building Permission	East: Plot No. - SMT BASANTI DEVI
Nature of Development: New	West: -
Location of Development Area: Old Area	
AREA DETAILS:	SQ.MT.
AREA OF PLOT (Minimum)	(A) 121.29
NET AREA OF PLOT(Gross Plot Area - Deduction from Gross Plot area)	(A-Deductions) 121.29
Deduction for Balance Plot Area(from Gross Plot Area)	
Common Plot	20.18
Total	20.18
BALANCE AREA OF PLOT(Net Plot Area - Recreational/Amenity space)	(A-Deductions) 101.12
PLOT AREA FOR COVERAGE(Net Plot Area)	(A-Deductions) 121.29
Plot Area for FAR (Net Plot Area + Road Widening Area)	(A-Deductions) 121.29
COVERAGE CHECK	
Permissible Coverage area (70.00 %)	84.90
Proposed Coverage Area (48.00 %)	58.22
Total Prop. Coverage Area (48 %)	58.22
Balance coverage area (22.00 %)	26.68
FAR CHECK	
Perm. FAR Area (1.50)	181.93
Total Perm. FAR area	181.93
Residential FAR	116.44
Proposed FAR Area	116.44
Total Proposed FAR Area	116.44
Consumed FAR (Factor)	0.96
Balance FAR Area	65.49
BUILT UP AREA CHECK	
Total Proposed BuiltUp Area	116.44
ARCHITECT (Regd)	Anil Kumar Singh
ENGINEER (Regd)	
SUPERVISOR (Regd)	
OWNER (Regd)	DEWANTI DEVI
DEVELOPMENT AUTHORITY LOCAL BODY	

Building :A (DEWANTI DEVI)

Floor Name	Total Built Up Area (Sq.mt.)	Proposed FAR Area (Sq.mt.) Resi.	Total FAR Area (Sq.mt.)	Total Consumed Additional FAR Area (Sq.mt.)	Tnmt (No.)
Ground Floor	58.22	58.22	58.22	58.22	01
First Floor	58.22	58.22	58.22	58.22	00
Terrace Floor	0.00	0.00	0.00	0.00	00
Total :	116.44	116.44	116.44	116.44	01
Total Number of Same Buildings :	1				
Total :	116.44	116.44	116.44	116.44	01

Buildingwise Floor FAR Details

Floor Name	Building Name A (DEWANTI DEVI)		Total	
	Proposed Built Up Area (Sq.mt.)	Proposed FAR Area (Sq.mt.)	Total Proposed Built Up Area (Sq.mt.)	Total FAR Area (Sq.mt.)
Ground Floor	58.22	58.22	58.22	58.22
First Floor	58.22	58.22	58.22	58.22
Terrace Floor	0.00	0.00	0.00	0.00
Total :	116.44	116.44	116.44	116.44

UnitBUA Table for Building :A (DEWANTI DEVI)

FLOOR	Name	UnitBUA Type	UnitBUA Area	Carpet Area	No. of Rooms	No. of Tenement
GROUND FLOOR PLAN	SPLIT A	FLAT	78.15	77.30	4	1
FIRST FLOOR PLAN	SPLIT A	FLAT	0.00	0.00	4	0
Total:	-	-	78.15	77.30	8	1

FAR & Tenement Details (Table 4c-1)

Building	No. of Same Bldg	Total Built Up Area (Sq.mt.)	Proposed FAR Area (Sq.mt.) Resi.	Total FAR Area (Sq.mt.)	Total Consumed Additional FAR Area (Sq.mt.)	Tnmt (No.)
A (DEWANTI DEVI)	1	116.44	116.44	116.44	116.44	01
Grand Total :	1	116.44	116.44	116.44	116.44	01

COLOR INDEX

PLOT BOUNDARY	Black
ABUTTING ROAD	Green
PROPOSED CONSTRUCTION	Red
COMMON PLOT	Blue
ROAD WIDENING AREA	Yellow
EXISTING (To be retained)	Orange
EXISTING (To be demolished)	Light Blue

