

SITE PLAN

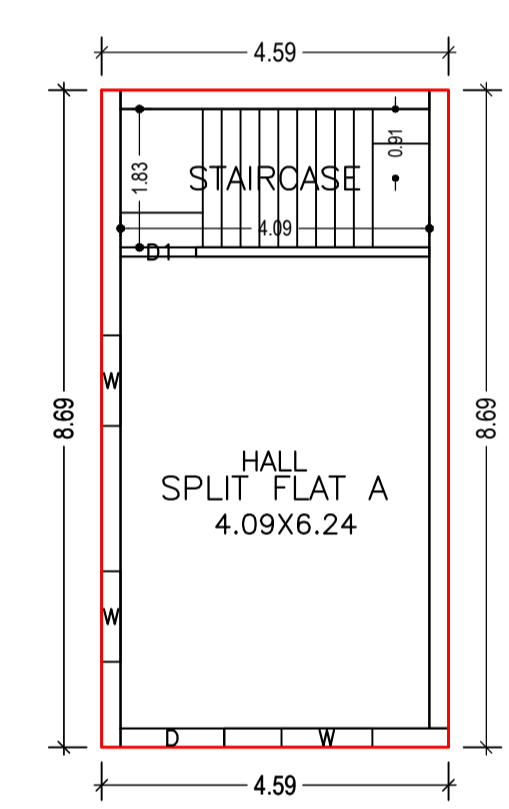

GROUND FLOOR PLAN (Proposed) (SCALE 1:100)

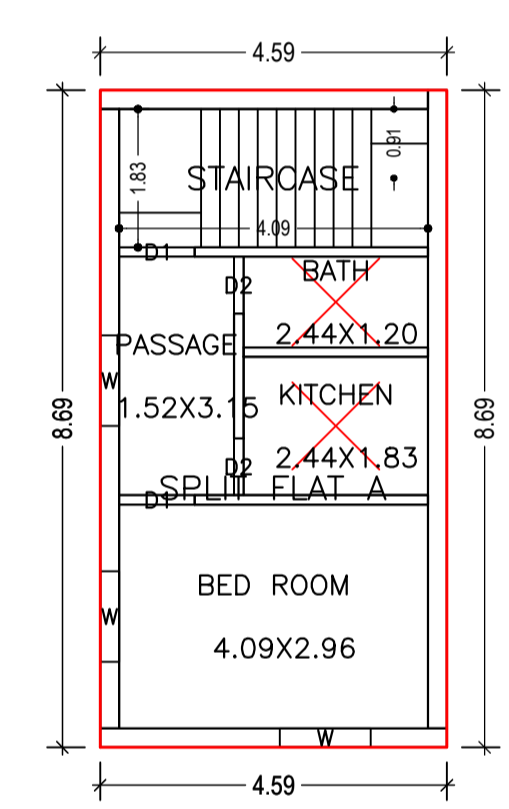

FIRST FLOOR PLAN (Proposed) (SCALE 1:100)

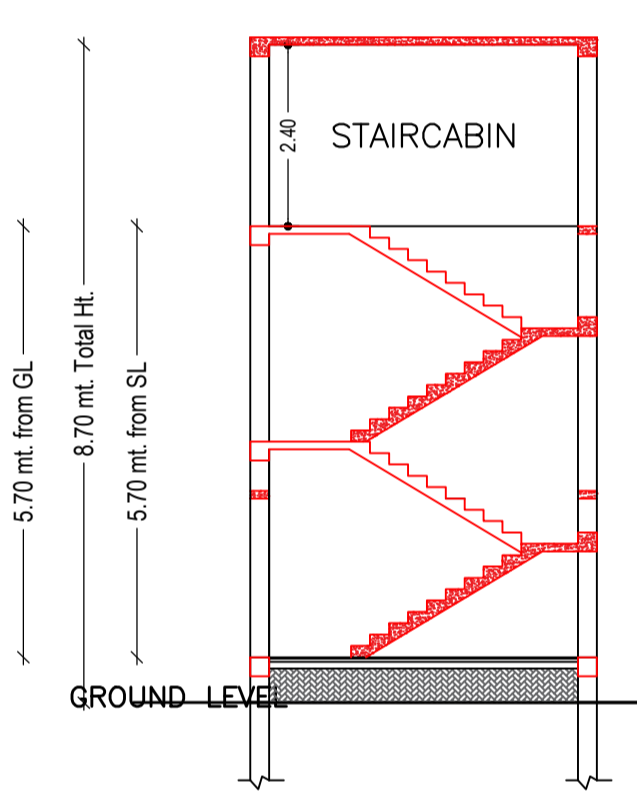

SECTION PLAN X-X

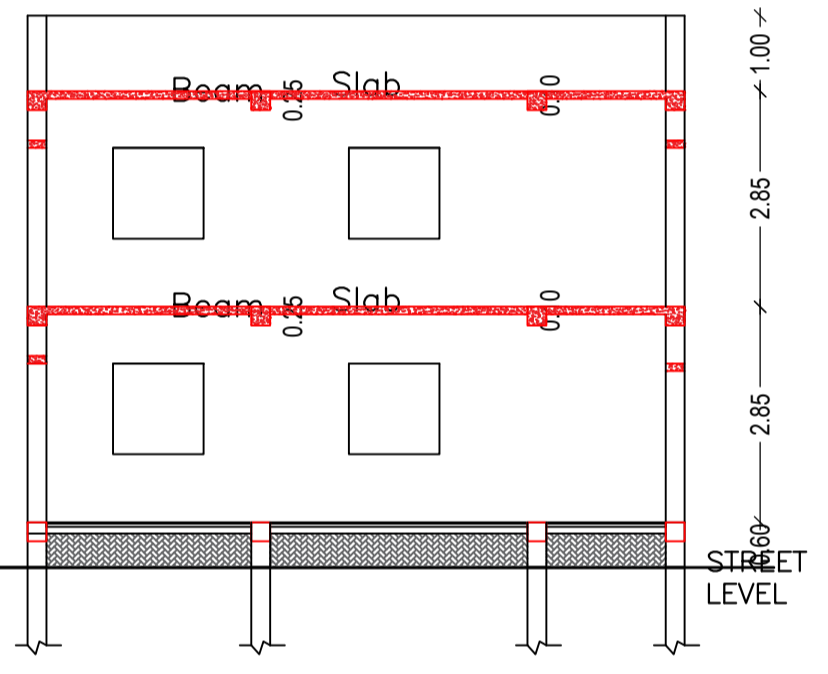

SECTION PLAN Y-Y

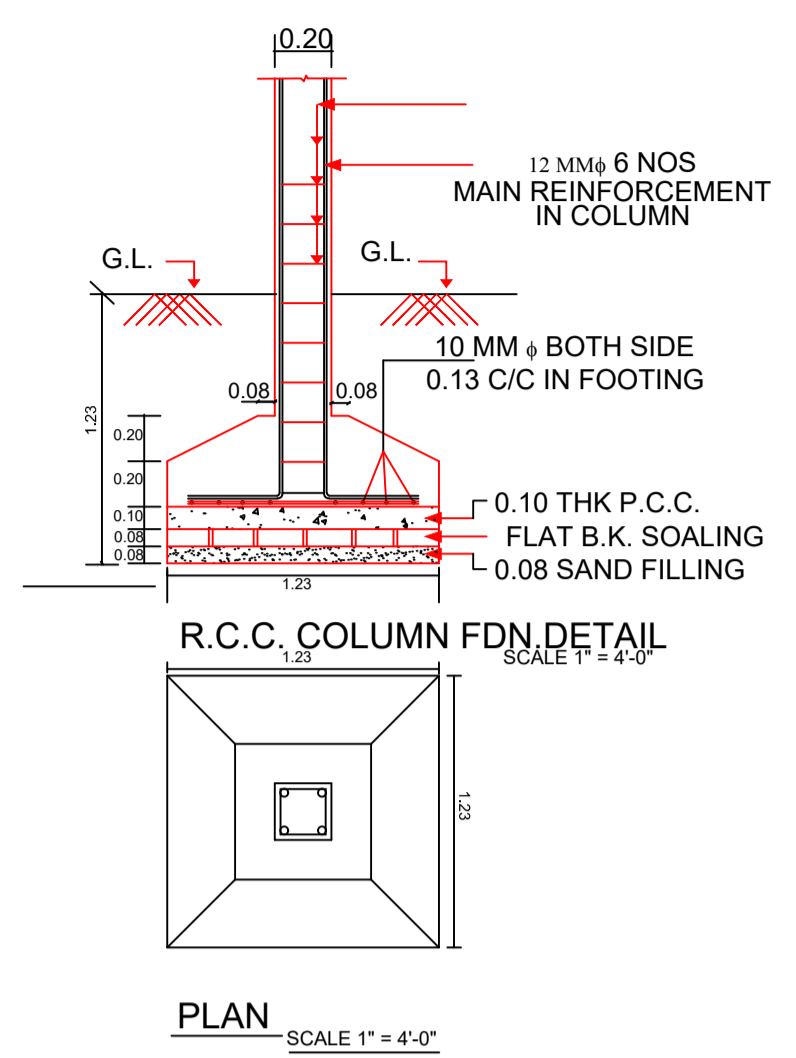

R.C.C. COLUMN FDN DETAIL (SCALE 1" = 4'-0")

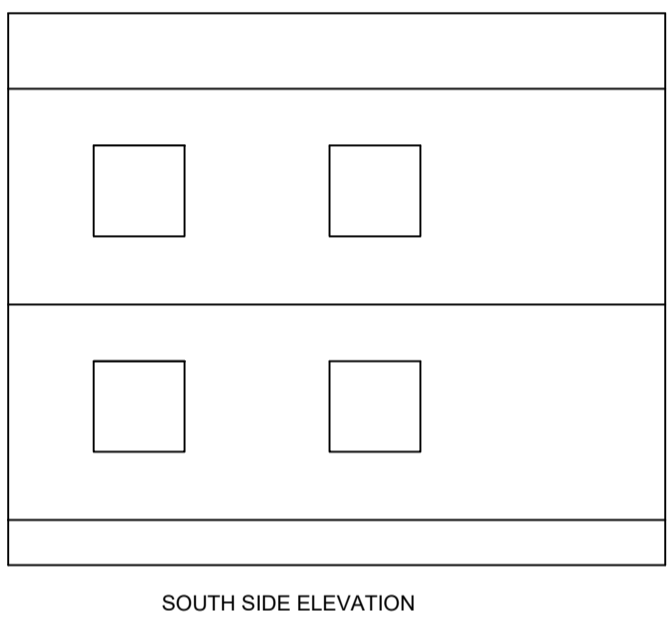
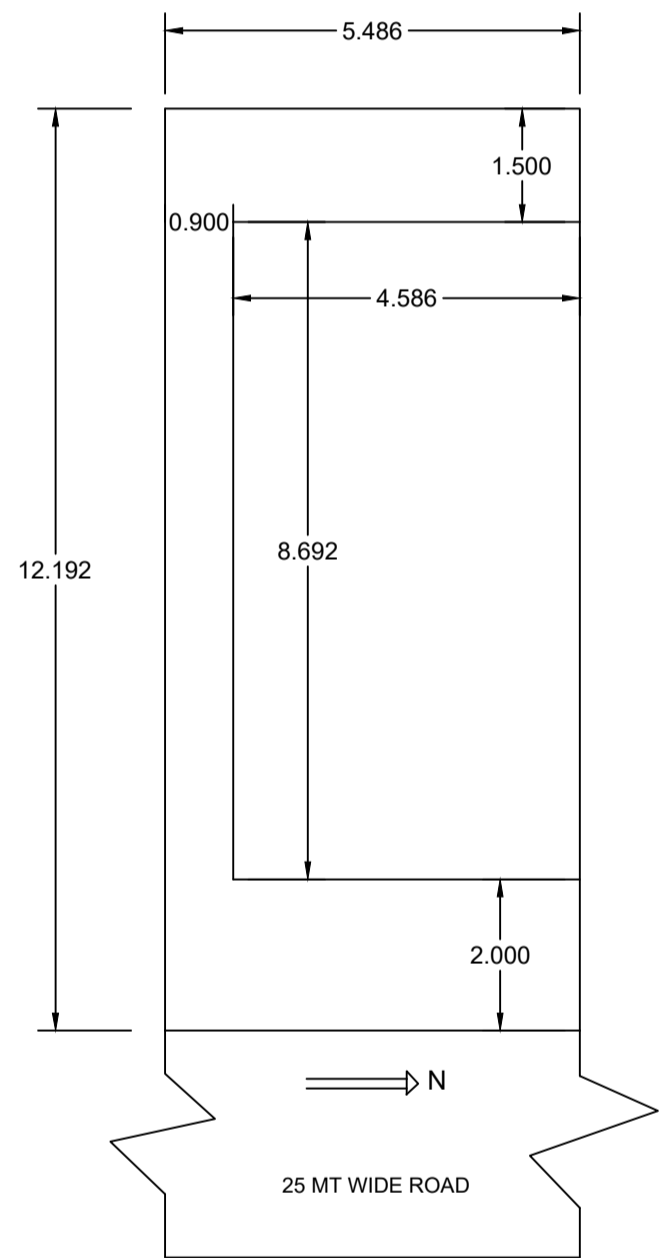

SOUTH SIDE ELEVATION

FAR & Tenement Details (Table 4c-1)

Building	No. of Same Bldg	Total Built Up Area (Sq.mt.)	Proposed FAR Area (Sq.mt.) Resi.	Total FAR Area (Sq.mt.)	Total Consumed Additional FAR Area (Sq.mt.)	Tnmt (No.)
AAA (BIRBAL SINGH)	1	79.72	79.72	79.72	79.72	01
Grand Total :	1	79.72	79.72	79.72	79.72	01

Proposal Basic Information

Proposal File No.	KONPC/BP/0014/W08/2022
Owner Name	BIRBAL SINGH
Khata No	48,524
Plot No	4495
Village Name	Koderma
Use	Residential
SubUse	Bungalow/ Dwelling / Non Apartment

AREA STATEMENT KODERMA NAGAR PANCHAYAT

VERSION NO : 1.0.62
VERSION DATE: 16/10/2020

PROJECT DETAIL:

Region: JHARKHAND URBAN LOCAL BODIES	Plot Use: Residential
District: KODERMA	Plot SubUse: Bungalow/ Dwelling / Non Apartment
Authority: KODERMA NAGAR PANCHAYAT	PlotNearbyReligiousStructure: NA
Inward No: KONPC/BP/0014/W08/2022	Plot/SubPlot No: 4495
Application Type: General Proposal	North: Plot No. - GIRDHARI PANDEY
Project Type: Building Permission	South: Plot No. - KHUSHI SINGH
Nature of Development: New	East: Road Width - 25
Location of Development Area: Old Area	West: Plot No. - MASUMAT JIRAIYA

AREA DETAILS:

DESCRIPTION	AREA (A)	SQ.MT.
NET AREA OF PLOT (Gross Plot Area)		66.89
- Deduction from Gross Plot area (A-Deductions)		66.89
Deduction for Balance Plot Area (from Gross Plot Area)		
Common Plot		9.93
Total		9.93
BALANCE AREA OF PLOT (Net Plot Area - Recreational/Amenity space)	(A-Deductions)	56.96
PLOT AREA FOR COVERAGE (Net Plot Area)	(A-Deductions)	66.89
Plot Area for FAR (Net Plot Area + Road Widening Area)	(A-Deductions)	66.89

COVERAGE CHECK

Permissible Coverage area (70.00 %)	46.82
Proposed Coverage Area (59.59 %)	39.86
Total Prop. Coverage Area (59.59 %)	39.86
Balance coverage area (10.41 %)	6.96

FAR CHECK

Perm. FAR Area (2.00)	133.78
Total Perm. FAR area	133.78
Residential FAR	79.72
Proposed FAR Area	79.72
Total Proposed FAR Area	79.72
Consumed FAR (Factor)	1.19
Balance FAR Area	54.06

BUILT UP AREA CHECK

Total Proposed BuiltUp Area	79.72
-----------------------------	-------

ARCHITECT (Regd) Amrendra Kumar
ENGINEER (Regd)
SUPERVISOR (Regd)
OWNER (Regd) BIRBAL SINGH

DEVELOPMENT AUTHORITY LOCAL BODY

COLOR INDEX

PLOT BOUNDARY	Black
ABUTTING ROAD	Green
PROPOSED CONSTRUCTION	Red
COMMON PLOT	Yellow
ROAD WIDENING AREA	Blue
EXISTING (To be retained)	Orange
EXISTING (To be demolished)	White

Building :AAA (BIRBAL SINGH)

Floor Name	Total Built Up Area (Sq.mt.)	Proposed FAR Area (Sq.mt.) Resi.	Total FAR Area (Sq.mt.)	Total Consumed Additional FAR Area (Sq.mt.)	Tnmt (No.)
Ground Floor	39.86	39.86	39.86	39.86	01
First Floor	39.86	39.86	39.86	39.86	00
Terrace Floor	0.00	0.00	0.00	0.00	00
Total :	79.72	79.72	79.72	79.72	01
Total Number of Same Buildings	1				
Total :	79.72	79.72	79.72	79.72	01

SCHEDULE OF DOOR:

BUILDING NAME	NAME	LENGTH	HEIGHT	NOS
AAA (BIRBAL SINGH)	D2	0.75	2.10	02
AAA (BIRBAL SINGH)	D1	1.00	2.10	03
AAA (BIRBAL SINGH)	D	1.37	2.10	01

SCHEDULE OF WINDOW/VENTILATION:

BUILDING NAME	NAME	LENGTH	HEIGHT	NOS
AAA (BIRBAL SINGH)	W	1.20	1.20	06

UnitBUA Table for Building :AAA (BIRBAL SINGH)

FLOOR	Name	UnitBUA Type	UnitBUA Area	Carpet Area	No. of Rooms	No. of Tenement
GROUND FLOOR PLAN	SPLIT FLAT A	FLAT	52.01	50.34	1	1
FIRST FLOOR PLAN	SPLIT FLAT A	FLAT	0.00	0.00	4	0
Total:	-	-	52.01	50.34	5	1

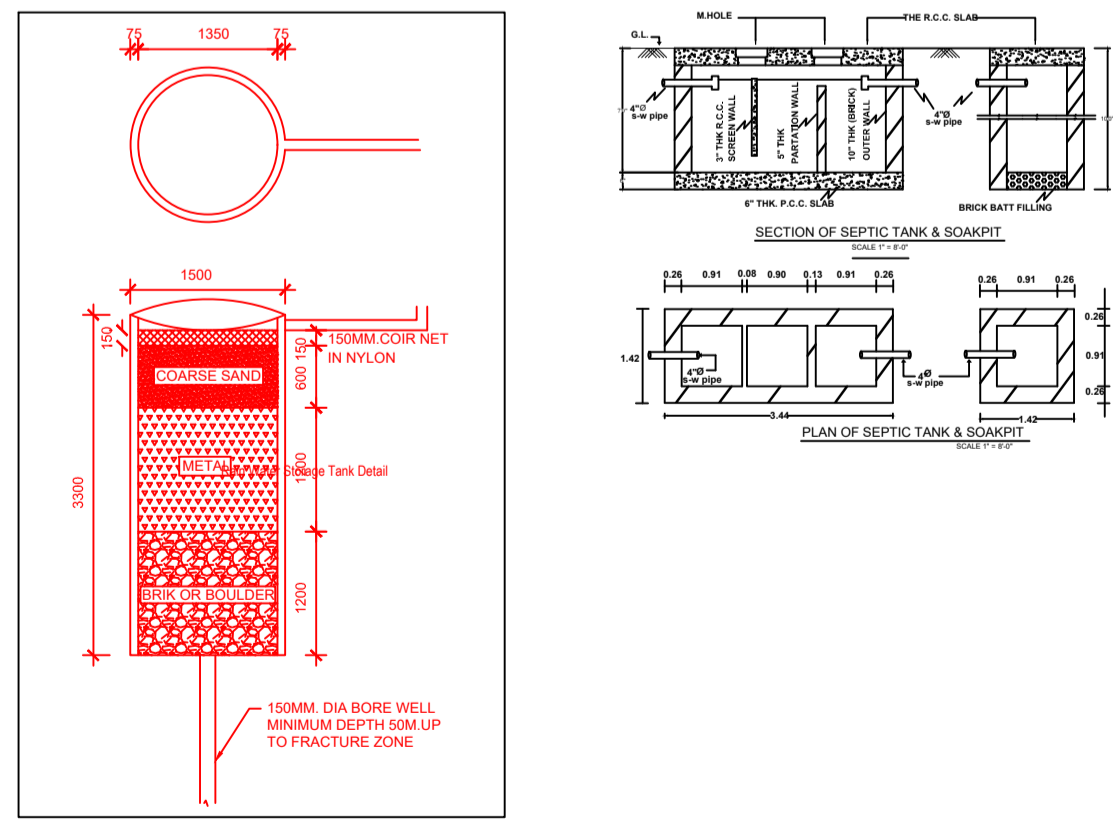

Buildingwise Floor FAR Details

Floor Name	Building Name AAA (BIRBAL SINGH)		Total	
	Proposed Built Up Area (Sq.mt.)	Proposed FAR Area (Sq.mt.)	Total Proposed Built Up Area (Sq.mt.)	Total FAR Area (Sq.mt.)
Ground Floor	39.86	39.86	39.86	39.86
First Floor	39.86	39.86	39.86	39.86
Terrace Floor	0.00	0.00	0.00	0.00
Total :	79.72	79.72	79.72	79.72

Building USE/SUBUSE Details

Building Name	Building Use	Building SubUse	Building Structure
AAA (BIRBAL SINGH)	Residential	Bungalow/ Dwelling / Non Apartment	Non-Highrise

LTP NAME AND SIGNATURE	STRUCTURAL ENG'S NAME AND SIGNATURE	BUILDER NAME AND SIGNATURE	DIGITAL SIGNATURE
Amrendra Kumar KONPC/SUP/0002/2017			