

Project Title :SUNITA DEVI

AREA STATEMENT: KODERMA NAGAR PANCHAYAT	VERSION NO. 1.0.32
PROJECT DETAIL:	VERSION DATE: 16/10/2020
Inward No. :-	Plot Use: Residential
Region :- JHARKHAND URBAN LOCAL BODIES	Plot Sub/Use: Bungalow/ Dwelling / Non Apartment
District: KODERMA	Land Use Zone: NA
Application Type: General Proposal	Abutting Road Width: -
Project Type: Building Permission	Plot No. :-
Nature of Development: New	Revenue Survey No/Survey No :-
Location: Old Area	Thana No: -
Sub Location: NA	Holding No: -
Village/Mauza Name :-	Khata No: -
Ward No: -	North: -
Road/Street :-	South: -
	East: -
	West: -

AREA DETAILS:		SQ.MT.
AREA OF PLOT (Minimum)	(A)	161.84
Net Plot Area (Gross Plot Area - Deductions from Gross Plot Area)	(A-Deductions)	161.84
Deductions for Balance Plot Area (from Gross Plot Area)		
COF Area		26.15
Total		26.15
Balance Plot Area (Net Plot Area - Recreational/Amenity space)	(A-Deductions)	136.68
Plot Area for Coverage (Net Plot Area)	(A-Deductions)	161.84
Plot Area for FSI (Net Plot Area + Road/Widening Area)	(A-Deductions)	161.84
Accessories Area		0.91
COVERAGE CHECK		
Proposed Coverage Area (46.05%)		74.53
Total Coverage Area (46.05%)		74.53
FAR CHECK		
Proposed Area of FAR		149.06
Total Area of FAR		149.06
BUILT UP AREA CHECK		
Total Proposed Built Up Area		149.06
ARCHT ENGR/ SUPERVISOR (Regd)	OWNER	
DEVELOPMENT AUTHORITY	LOCAL BODY	

COLOR INDEX	
PLOT BOUNDARY	██████████
ABUTTING ROAD	██████████
PROPOSED WORK (COVERAGE AREA)	██████████
EXISTING (To be retained)	██████████
EXISTING (To be demolished)	██████████

Color Index:		
PARKING CALCULATION:		
Parking Type	Prop No.	Prop Area
Other Parking	1	12.58
Total Area	1	12.58

MARGIN DETAIL:					
Building / Wing Name	Road Name	Front Margin	Rear Margin	Side1 Margin	Side2 Margin
A1 (SUNITA DEVI)	4.60 MTR WIDE ROAD Access Road	2.80	4.51	0.94	0.30

FAR & Tenement Details (Table 4c-1)					
Building	No. of Same Bldg	Total Built Up Area (Sq.mt.)	Proposed FAR Area (Sq.mt.)	Total FAR Area (Sq.mt.)	Trmt (No.)
A (SUNITA DEVI)	1	149.06	149.06	149.06	01
Grand Total:	1	149.06	149.06	149.06	01

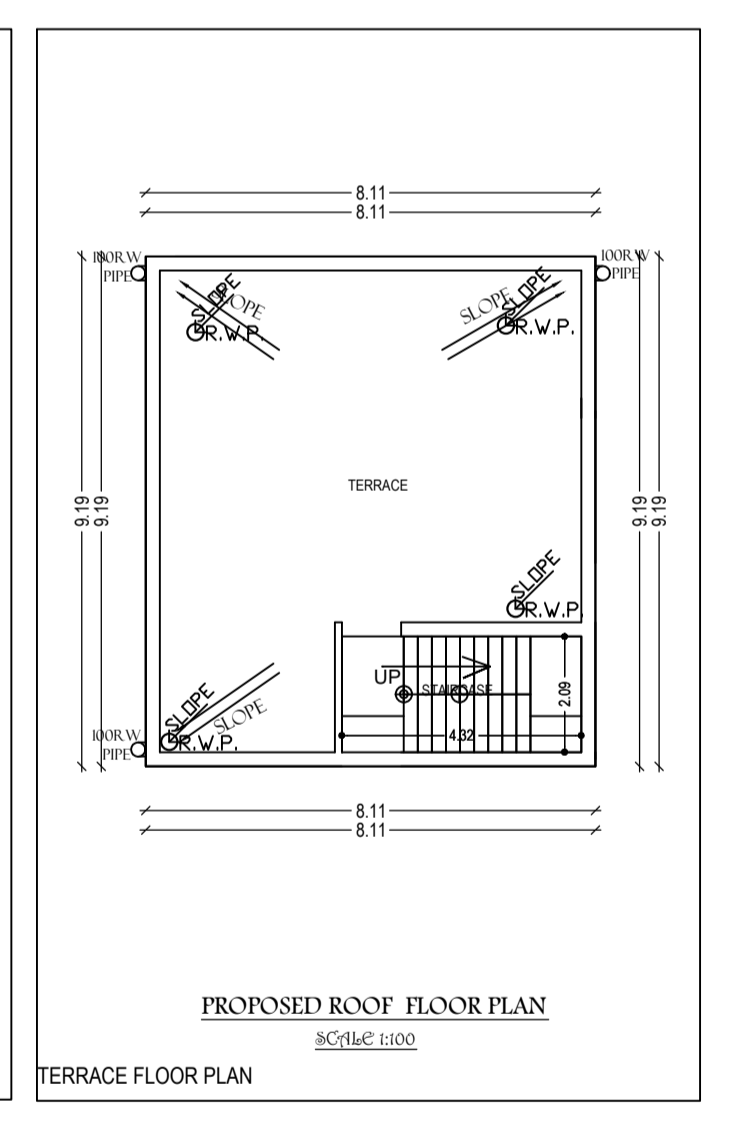
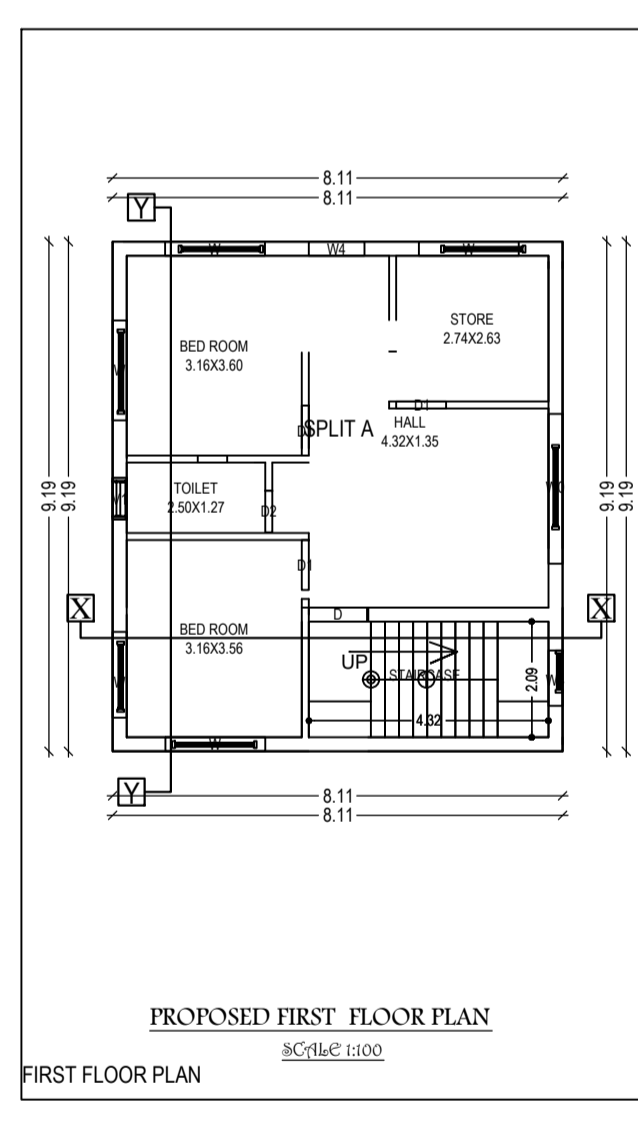
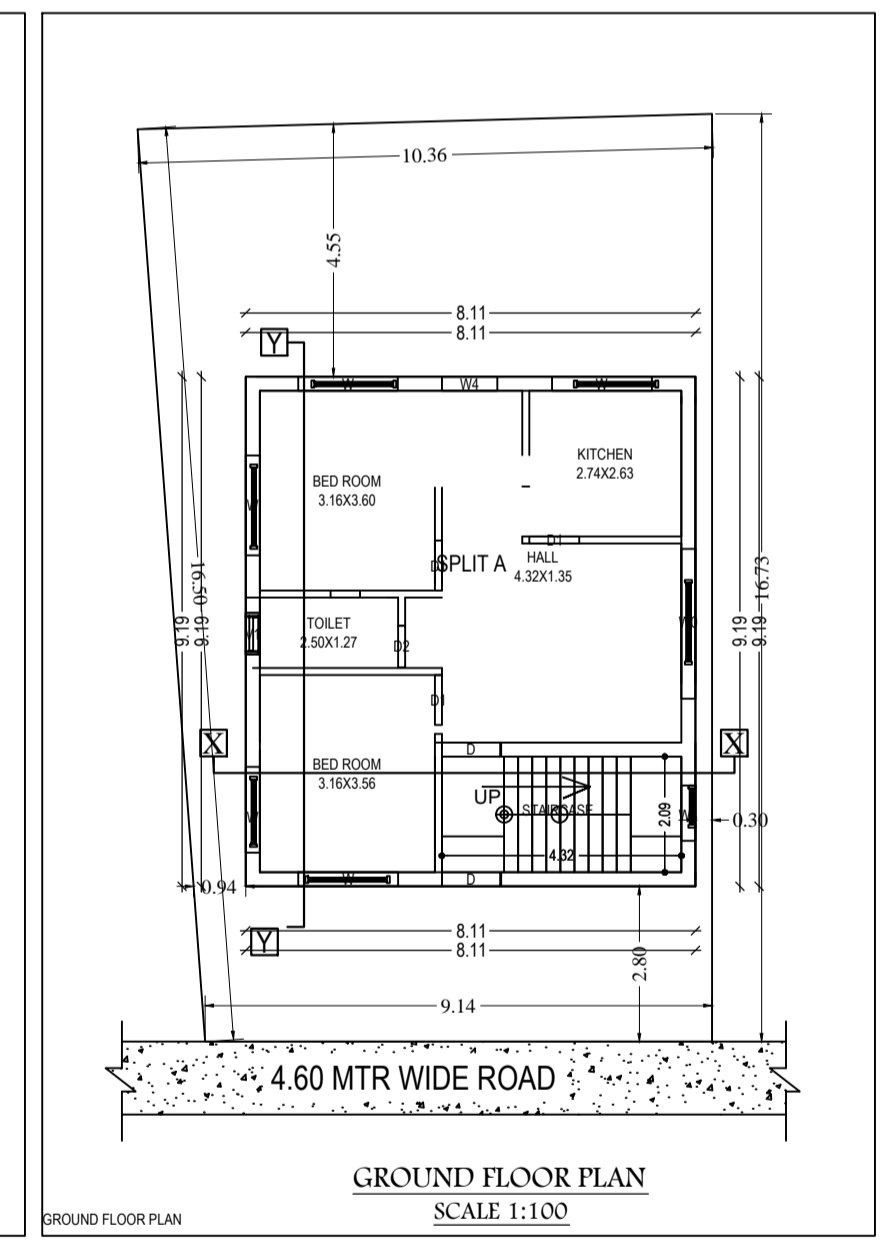
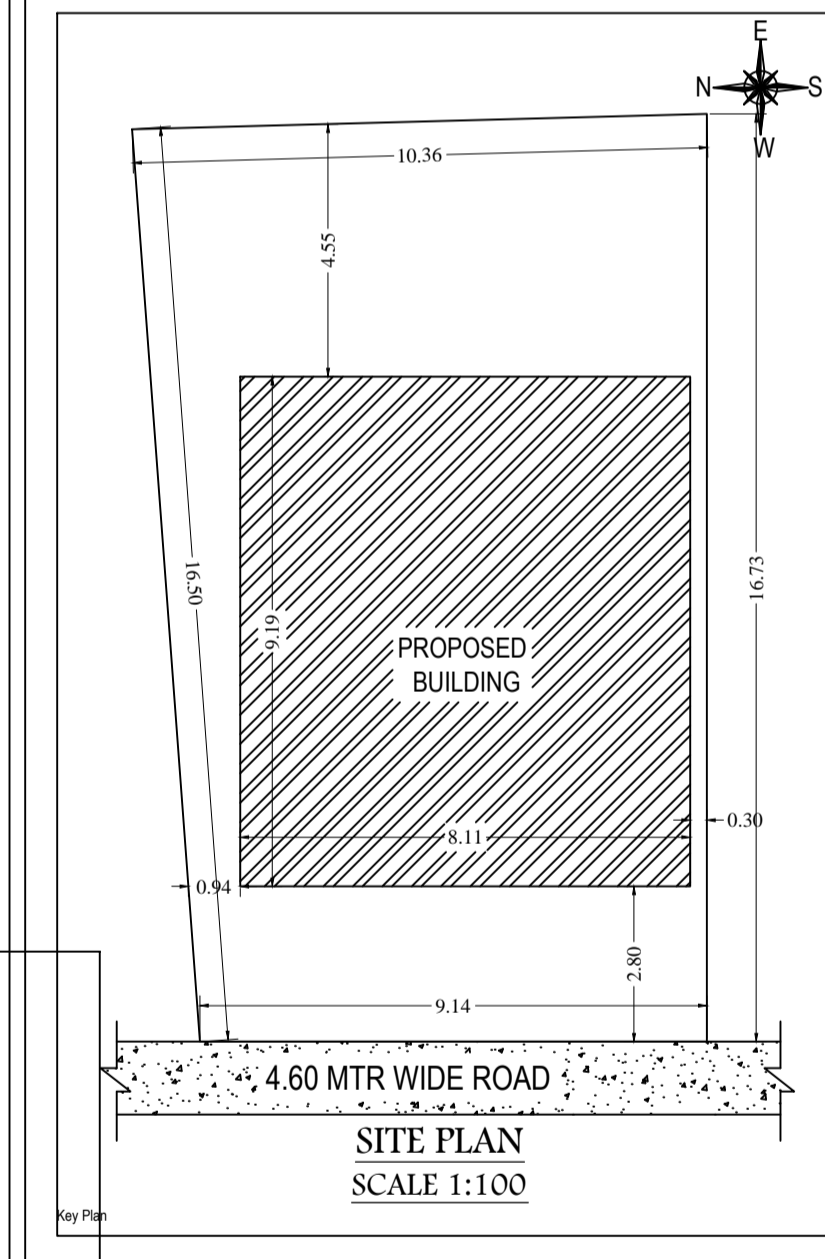
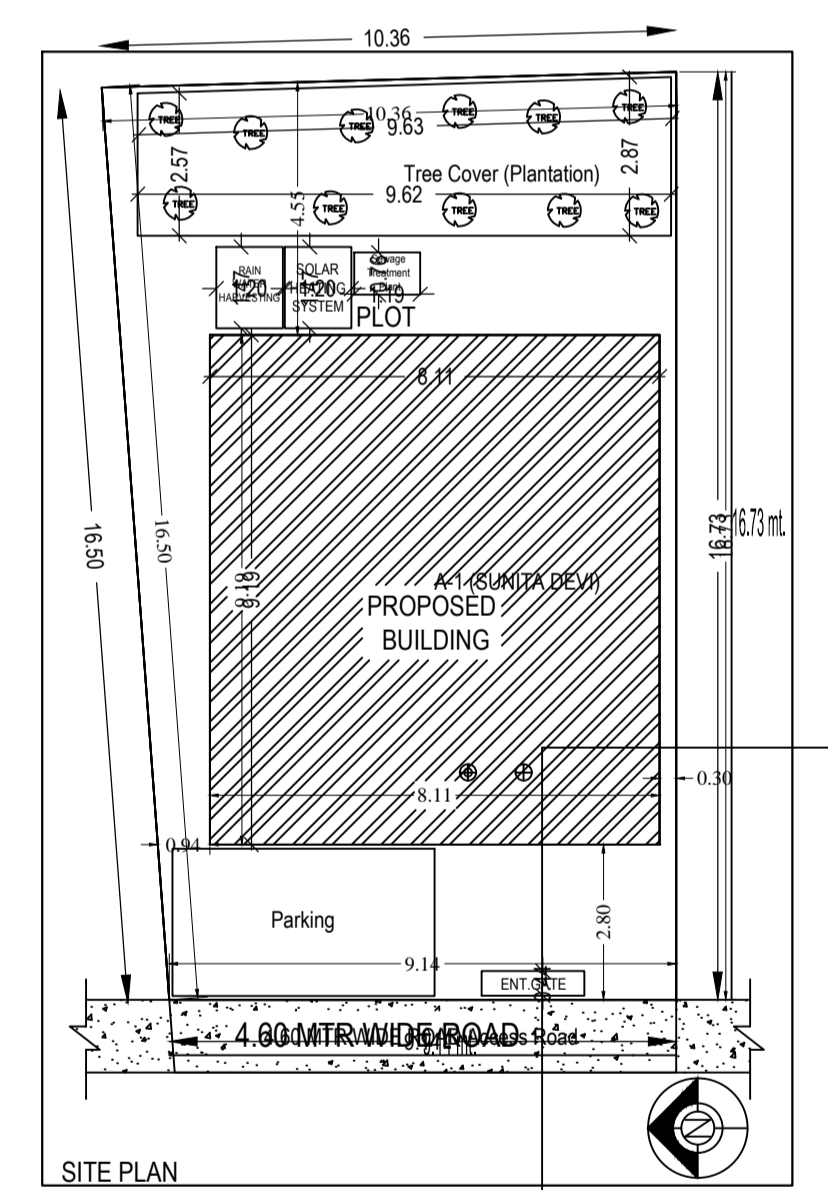
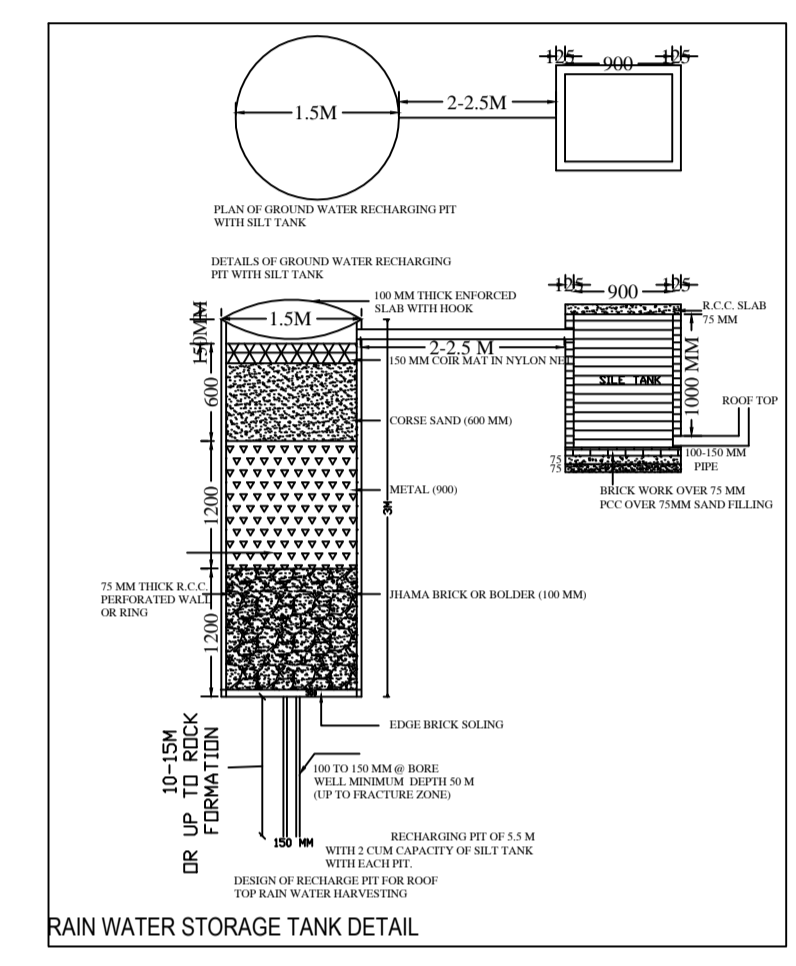
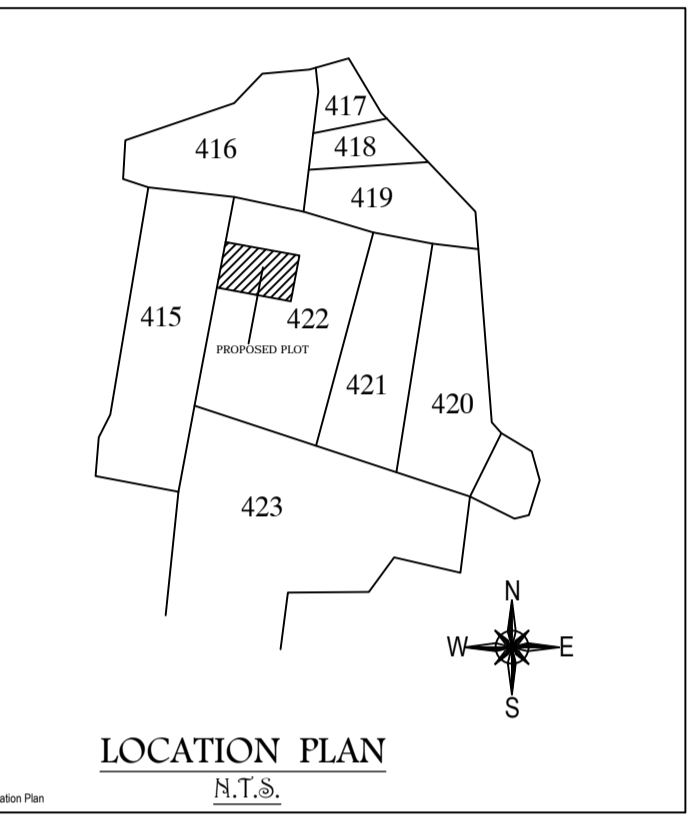
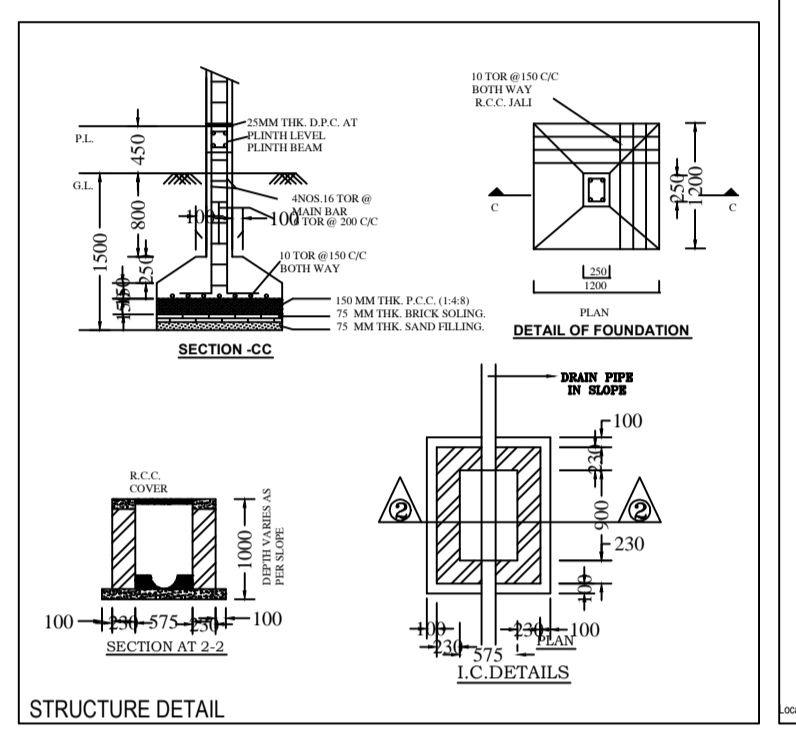
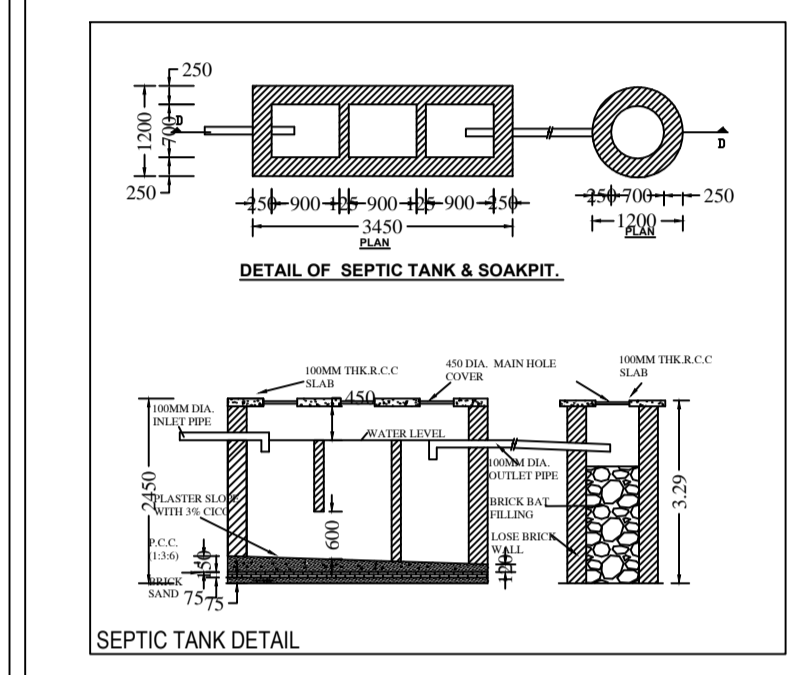
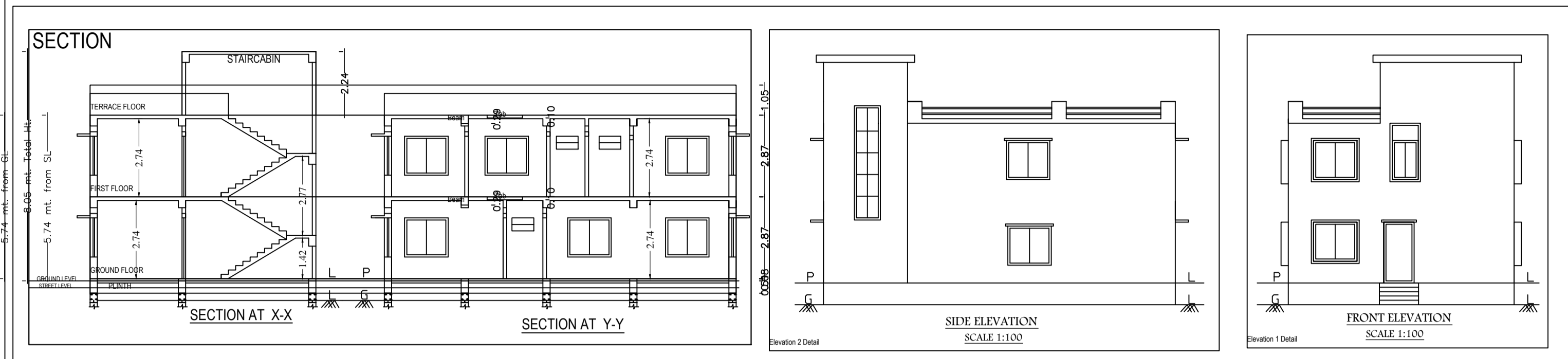

LAND DETAILS

PROPOSED RESIDENTIAL BUILDING PLAN OF SUNITA DEVI

W/O MR. RAMKUMAR RAM
 PLOT NO. - 422, KHATA NO-2
 VILLAGE - NAGAR KHANA, KODERMA
 WARD NO-4, THANA NO - 329
 DISTRICT. - KODARMA
 STATE -- JHARKHAND.

Applicant's Signature.	SIGNATURE OF LIC. ENGINEER

Building 'A' (SUNITA DEVI)				
Floor Name	Total Built Up Area (Sq.mt.)	Proposed FAR Area (Sq.mt.)	Total FAR Area (Sq.mt.)	Trmt (No.)
Ground Floor...	74.53	74.53	74.53	01
First Floor...	74.53	74.53	74.53	00
Terrace Floor...	0.00	0.00	0.00	00
Total:	149.06	149.06	149.06	01
Total Number of Same Buildings	1			
Total:	149.06	149.06	149.06	01

SCHEDULE OF JOINERY:				
BUILDING NAME	NAME	LENGTH	HEIGHT	NOS
A (SUNITA DEVI)	D2	0.75	2.13	02
A (SUNITA DEVI)	D1	0.90	2.13	06
A (SUNITA DEVI)	D	1.90	2.13	03
Total	-	-	-	11

SCHEDULE OF JOINERY:				
BUILDING NAME	NAME	LENGTH	HEIGHT	NOS
A (SUNITA DEVI)	V1	0.75	1.00	02
A (SUNITA DEVI)	W4	1.00	2.70	04
A (SUNITA DEVI)	W	1.55	2.70	02
A (SUNITA DEVI)	W	1.90	2.70	06
A (SUNITA DEVI)	W0	2.70	2.70	02
Total	-	-	-	18

UnitBUA Table for Building 'A' (SUNITA DEVI)						
FLOOR	Name	UnitBUA Type	UnitBUA Area	Carpet Area	No. of Rooms	No. of Tenement
GROUND FLOOR PLAN	SPLIT A	FLAT	111.19	111.06	5	1
Total	-	-	111.19	111.06	10	1