

SITE PLAN

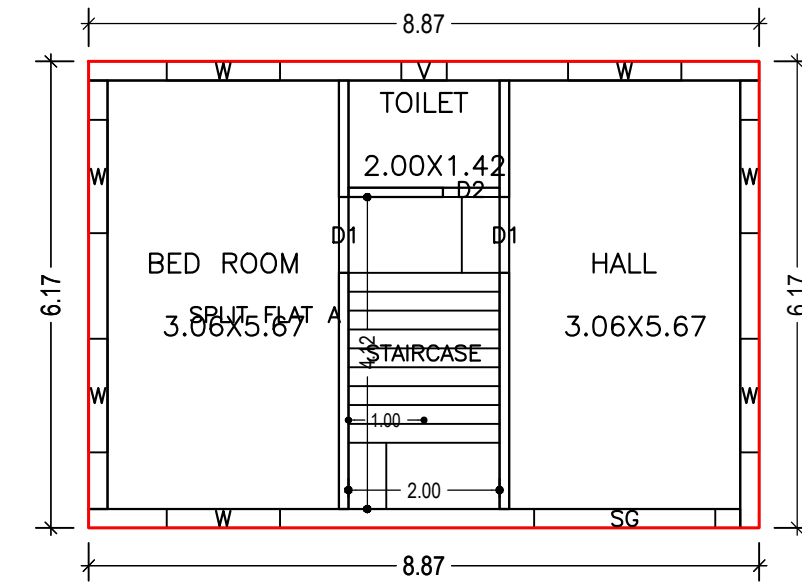

GROUND FLOOR PLAN (Proposed) (SCALE 1:100)

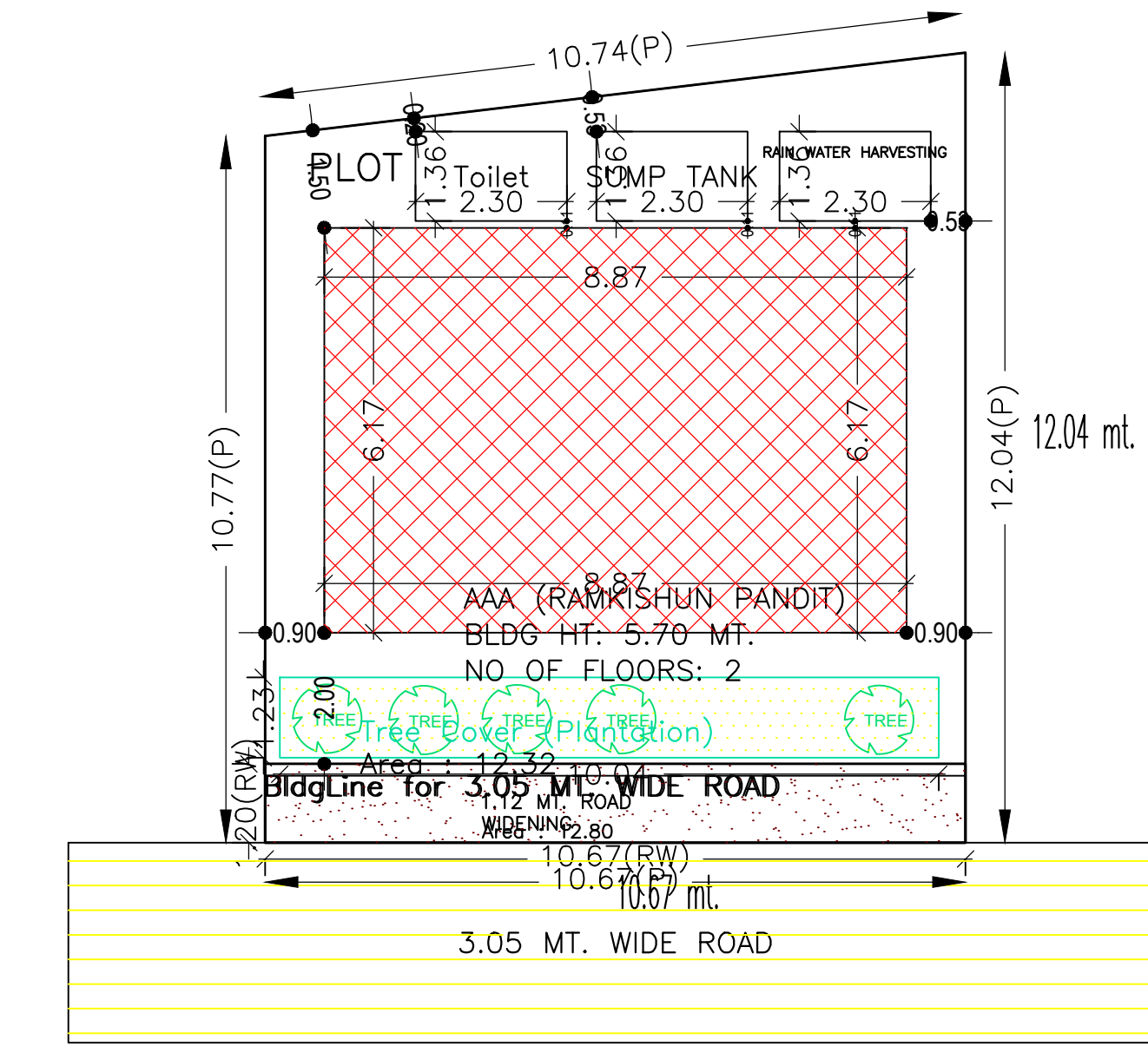
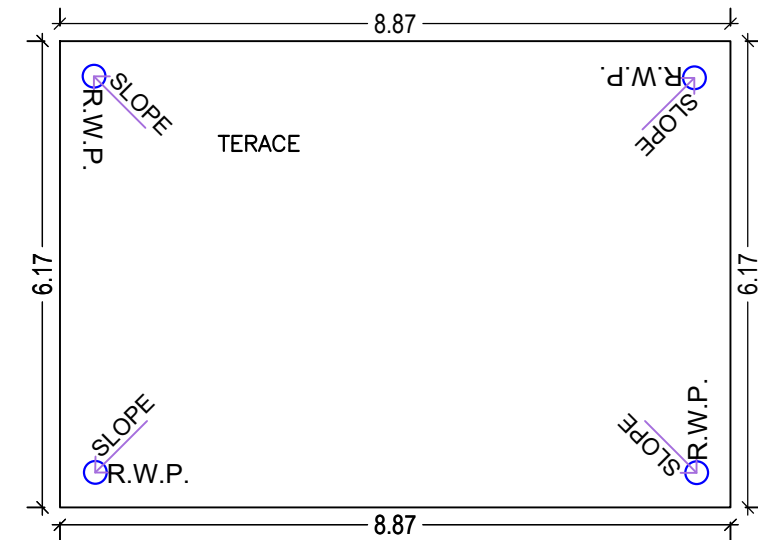

TERRACE FLOOR PLAN (SCALE 1:100)

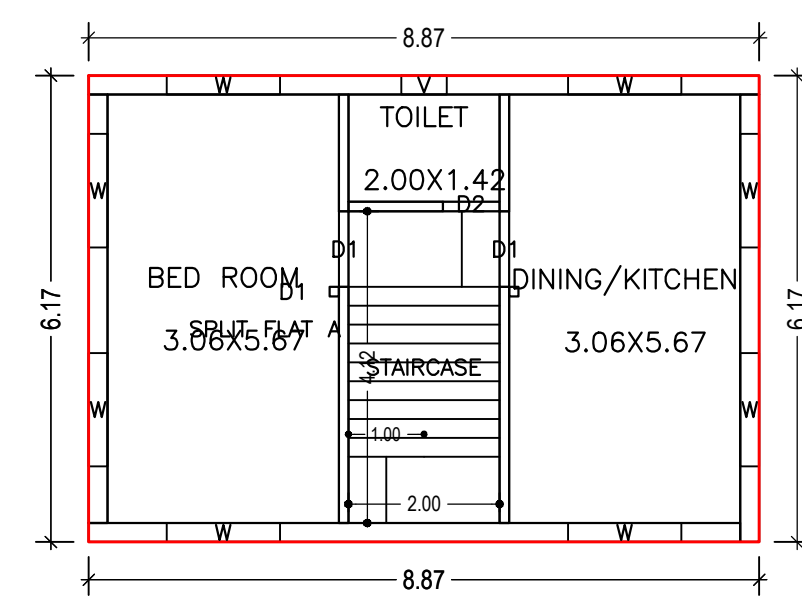

FIRST FLOOR PLAN (Proposed) (SCALE 1:100)

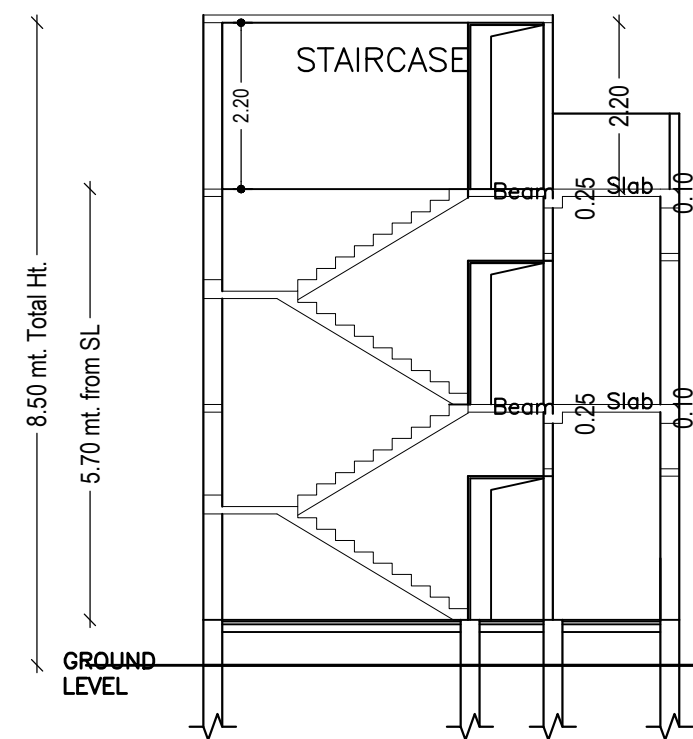

SECTION PLAN X - X (SCALE 1:100)

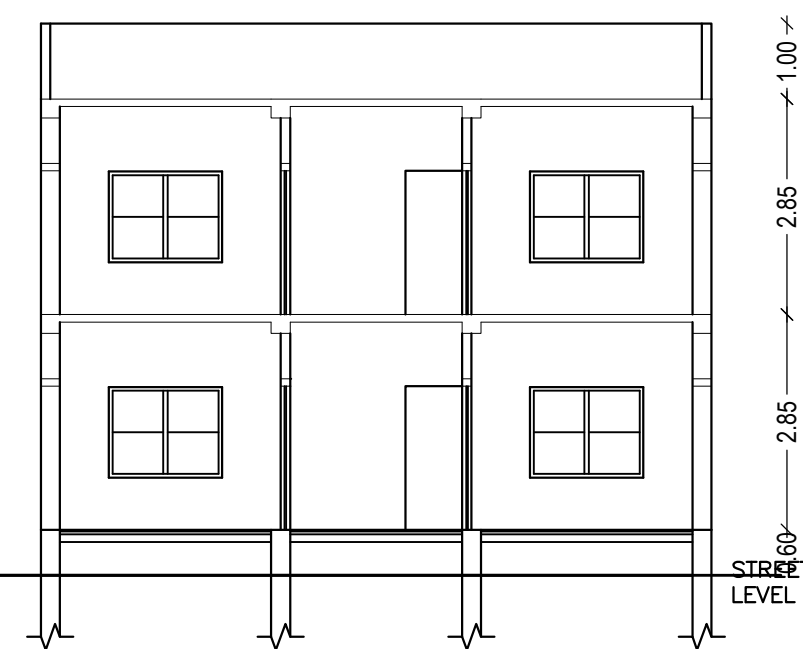

SECTION PLAN Y - Y (SCALE 1:100)

Building :AAA (RAMKISHUN PANDIT)

Floor Name	Total Built Up Area (Sq.mt.)	Proposed FAR Area (Sq.mt.) Resi.	Total FAR Area (Sq.mt.)	Total Consumed Additional FAR Area (Sq.mt.)	Tnmt (No.)
Ground Floor	54.73	54.73	54.73	54.73	01
First Floor	54.73	54.73	54.73	54.73	00
Terrace Floor	0.00	0.00	0.00	0.00	00
Total :	109.46	109.46	109.46	109.46	01
Total Number of Same Buildings	1				
Total :	109.46	109.46	109.46	109.46	01

SCHEDULE OF DOOR:

BUILDING NAME	NAME	LENGTH	HEIGHT	NOS
AAA (RAMKISHUN PANDIT)	D2	0.75	2.10	02
AAA (RAMKISHUN PANDIT)	D1	1.00	2.10	04
AAA (RAMKISHUN PANDIT)	SG	2.40	2.10	01

SCHEDULE OF WINDOW/VENTILATION:

BUILDING NAME	NAME	LENGTH	HEIGHT	NOS
AAA (RAMKISHUN PANDIT)	V	0.60	0.50	02
AAA (RAMKISHUN PANDIT)	W	1.50	1.20	15

UnitBUA Table for Building :AAA (RAMKISHUN PANDIT)

FLOOR	Name	UnitBUA Type	UnitBUA Area	Carpet Area	No. of Rooms	No. of Tenement
GROUND FLOOR PLAN	SPLIT FLAT A	FLAT	77.38	75.49	3	1
FIRST FLOOR PLAN	SPLIT FLAT A	FLAT	0.00	0.00	3	0
Total:	-	-	77.38	75.49	6	1

FAR & Tenement Details (Table 4c-1)

Building	No. of Same Bldg	Total Built Up Area (Sq.mt.)	Proposed FAR Area (Sq.mt.) Resi.	Total FAR Area (Sq.mt.)	Total Consumed Additional FAR Area (Sq.mt.)	Tnmt (No.)
AAA (RAMKISHUN PANDIT)	1	109.46	109.46	109.46	109.46	01
Grand Total :	1	109.46	109.46	109.46	109.46	01

Proposal Basic Information

Proposal File No.	KONPC/BI/0032/W07/2022
Owner Name	RAMKISHUN PANDIT
Khata No	636
Plot No	1254
Village Name	Kodarma
Use	Residential
SubUse	Bungalow/ Dwelling / Non Apartment

AREA STATEMENT		VERSION NO. : 1.0.65
KODERMA NAGAR PANCHAYAT		VERSION DATE: 16/10/2020
PROJECT DETAIL:		
Region: JHARKHAND URBAN LOCAL BODIES	Plot Use: Residential	
District: KODERMA	Plot SubUse: Bungalow/ Dwelling / Non Apartment	
Authority: KODERMA NAGAR PANCHAYAT	PlotNearby/ReligiousStructure: NA	
Inward No: KONPC/BI/0032/W07/2022	Plot/SubPlot No: 1254	
Application Type: General Proposal	North: Plot No. - PLOT NO 1255	
Project Type: Building Permission	South: Road Width - 3.05	
Nature of Development: New	East: Plot No. - SMT JUNI SINHA	
Location of Development Area: Old Area	West: Plot No. - JEETENDRA KUMAR	
AREA DETAILS:		SQ.MT.
AREA OF PLOT (Minimum)	(A)	115.26
Deduction for NetPlot Area		
Road Widening Area		12.80
Total		12.80
NET AREA OF PLOT(Gross Plot Area - Deduction from Gross Plot area)	(A-Deductions)	102.46
Deduction for Balance Plot Area(from Gross Plot Area)		
Road Widening Area		12.80
Total		12.32
BALANCE AREA OF PLOT(Net Plot Area - Recreational/Amenity space)	(A-Deductions)	90.14
PLOT AREA FOR COVERAGE(Net Plot Area)	(A-Deductions)	102.46
Plot Area for FAR (Net Plot Area + RoadWidening Area)	(A-Deductions)	102.46
COVERAGE CHECK		
Permissible Coverage area (70.00 %)		71.72
Proposed Coverage Area (53.42 %)		54.73
Total Prop. Coverage Area (53.42 %)		54.73
Balance coverage area (16.58 %)		16.99
FAR CHECK		
Perm. FAR Area (1,200)		122.95
Total Perm. FAR area		122.95
Residential FAR		109.46
Proposed FAR Area		109.46
Total Proposed FAR Area		109.46
Consumed FAR (Factor)		1.07
Balance FAR Area		13.49
BUILT UP AREA CHECK		
Total Proposed BuiltUp Area		109.46
ARCHITECT (Regd)	Amrendra Kumar	
ENGINEER (Regd)		
SUPERVISOR (Regd)		
OWNER (Regd)	RAMKISHUN PANDIT	
DEVELOPMENT AUTHORITY		LOCAL BODY

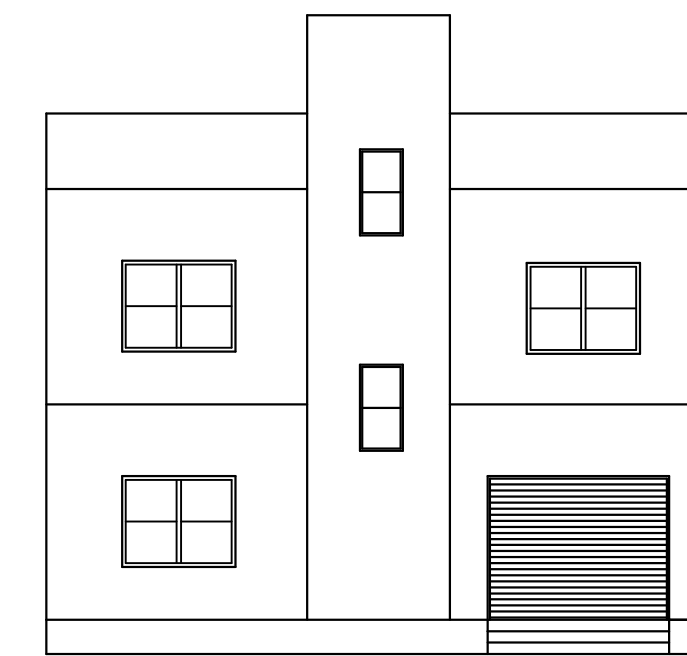
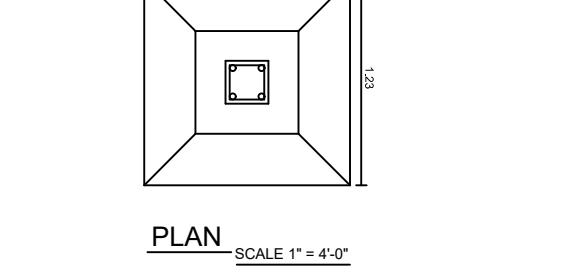
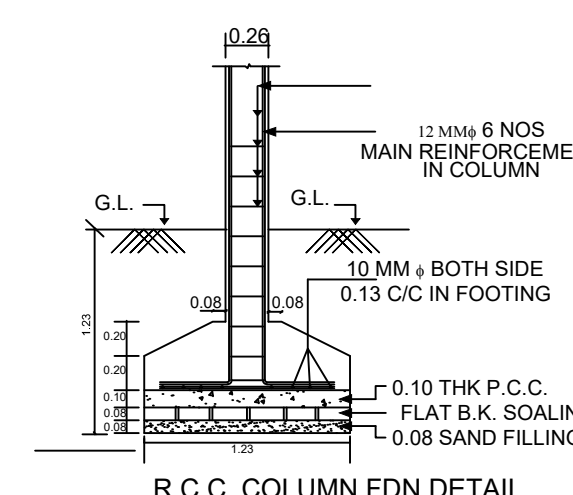
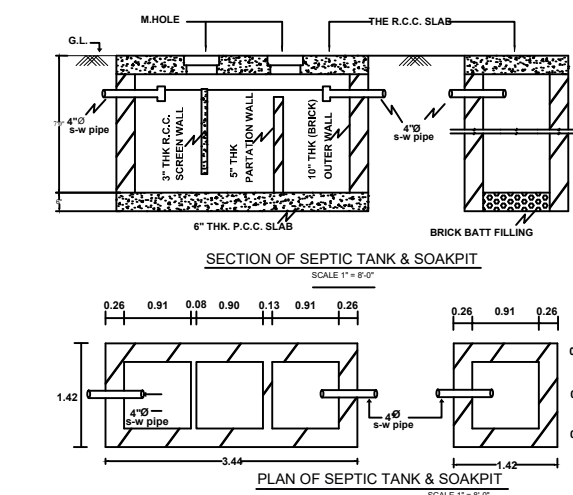

FORNT ELEVATION PLAN (SCALE 1:100)

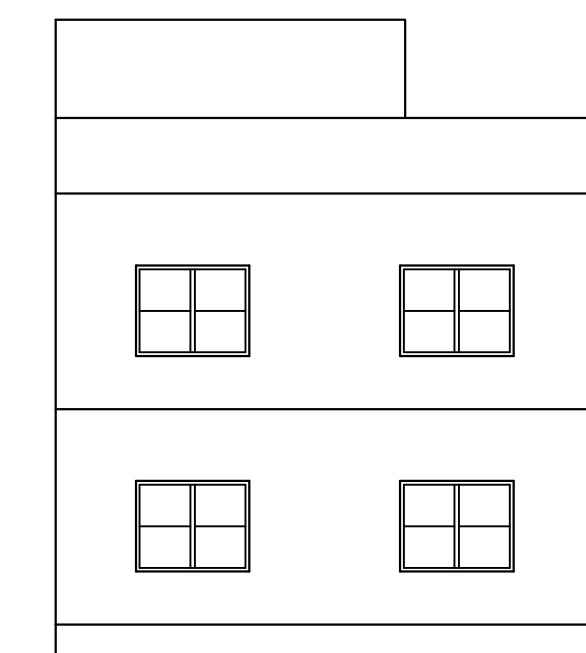

SIDE ELEVATION PLAN (SCALE 1:100)

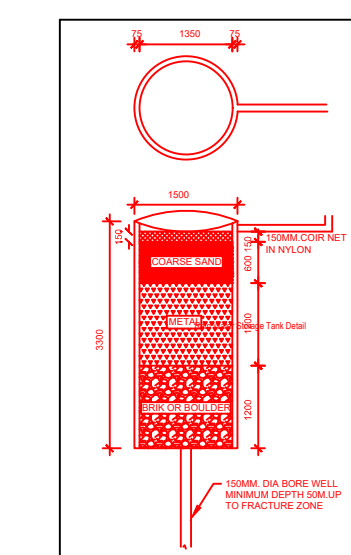

Color Index	Description
Black	PLOT BOUNDARY
Green	ABUTTING ROAD
Red	PROPOSED CONSTRUCTION
Yellow	COMMON PLOT
Blue	ROAD WIDENING AREA
Orange	EXISTING (To be retained)
White	EXISTING (To be demolished)

Buildingwise Floor FAR Details

Floor Name	Building Name AAA (RAMKISHUN PANDIT)		Total	
	Proposed Built Up Area (Sq.mt.)	Proposed FAR Area (Sq.mt.)	Total Proposed Built Up Area (Sq.mt.)	Total FAR Area (Sq.mt.)
Ground Floor	54.73	54.73	54.73	54.73
First Floor	54.73	54.73	54.73	54.73
Terrace Floor	0.00	0.00	0.00	0.00
Total :	109.46	109.46	109.46	109.46

Building USE/SUBUSE Details

Building Name	Building Use	Building SubUse	Building Structure
AAA (RAMKISHUN PANDIT)	Residential	Bungalow/ Dwelling / Non Apartment	Non-Highrise

LTP NAME AND SIGNATURE	STRUCTURAL ENG'S NAME AND SIGNATURE	BUILDER NAME AND SIGNATURE	DIGITAL SIGNATURE
Amrendra Kumar KONPC/SUP/0002/2017			