

SITE PLAN

FAR & Tenement Details (Table 4c-1)

Building	No. of Same Bldg	Total Built Up Area (Sq.mt.)	Proposed FAR Area (Sq.mt.) Resi.	Total FAR Area (Sq.mt.)	Total Consumed Additional FAR Area (Sq.mt.)	Tnmt (No.)
AAA (JAGDISH PD YADAV)	1	138.14	138.14	138.14	138.14	01
Grand Total :	1	138.14	138.14	138.14	138.14	01

Proposal Basic Information

Proposal File No.	KONPC/BP/0002/W06/2023
Owner Name	JAGDISH PRASAD YADAV
Khata No	169
Plot No	1159
Village Name	Kodarma
Use	Residential
SubUse	Bungalow/ Dwelling / Non Apartment

AREA STATEMENT	VERSION NO. : 1.0.65
KODERMA NAGAR	VERSION DATE: 16/10/2020
PANCHAYAT	
PROJECT DETAIL:	
Region: JHARKHAND URBAN LOCAL BODIES	Plot Use: Residential
District: KODERMA	Plot SubUse: Bungalow/ Dwelling / Non Apartment
Authority: KODERMA NAGAR PANCHAYAT	PlotNearby/Religious/Structure: NA
Inward No: KONPC/BP/0002/W06/2023	Plot/SubPlot No: 1159
Application Type: General Proposal	North: Plot No. - MODI MIYAN
Project Type: Building Permission	South: Plot No. - MUKESH RAM
Nature of Development: New	East: Road Width - 3.05 MT
Location of Development Area: Old Area	West: Plot No. - BINOD KUMAR SINHA
AREA DETAILS:	SQ.MT.
AREA OF PLOT (Minimum)	(A) 251.18
Deduction for NetPlot Area	
Road Widening Area	7.88
Total	7.88
NET AREA OF PLOT(Gross Plot Area - Deduction from Gross Plot area)	(A-Deductions) 243.30
Deduction for Balance Plot Area(from Gross Plot Area)	
Road Widening Area	7.88
Common Plot	67.52
Total	75.41
BALANCE AREA OF PLOT(Net Plot Area - Recreational/Amenity space)	(A-Deductions) 175.77
PLOT AREA FOR COVERAGE(Net Plot Area)	(A-Deductions) 243.30
Plot Area for FAR (Net Plot Area + RoadWidening Area)	(A-Deductions) 243.30
COVERAGE CHECK	
Permissible Coverage area (60.00 %)	145.98
Proposed Coverage Area (28.39 %)	69.07
Total Prop. Coverage Area (28.39 %)	69.07
Balance coverage area (31.61 %)	76.91
FAR CHECK	
Perm. FAR Area (1,200)	291.96
Total Perm. FAR area	291.96
Residential FAR	138.13
Proposed FAR area	138.13
Total Proposed FAR Area	138.13
Consumed FAR (Factor)	0.57
Balance FAR Area	153.83
BUILT UP AREA CHECK	
Total Proposed BuiltUp Area	138.14
ARCHITECT (Regd)	Amrendra Kumar
ENGINEER (Regd)	
SUPERVISOR (Regd)	
OWNER (Regd)	JAGDISH PRASAD YADAV
DEVELOPMENT AUTHORITY	LOCAL BODY

COLOR INDEX	
PLOT BOUNDARY	Black
ABUTTING ROAD	Green
PROPOSED CONSTRUCTION	Red
COMMON PLOT	Yellow
ROAD WIDENING AREA	Blue
EXISTING (To be retained)	Light Blue
EXISTING (To be demolished)	Light Yellow

Buildingwise Floor FAR Details

Floor Name	Building Name		Total	
	Proposed Built Up Area (Sq.mt.)	Proposed FAR Area (Sq.mt.)	Total Proposed Built Up Area (Sq.mt.)	Total FAR Area (Sq.mt.)
Ground Floor	69.07	69.07	69.07	69.07
First Floor	69.07	69.07	69.07	69.07
Terrace Floor	0.00	0.00	0.00	0.00
Total :	138.14	138.14	138.14	138.14

Building USE/SUBUSE Details

Building Name	Building Use	Building SubUse	Building Structure
AAA (JAGDISH PD YADAV)	Residential	Bungalow/ Dwelling / Non Apartment	Non-Highrise

LTP NAME AND SIGNATURE	STRUCTURAL ENG'S NAME AND SIGNATURE	BUILDER NAME AND SIGNATURE	DIGITAL SIGNATURE
Amrendra Kumar KONPC/SUP/0002/2017			

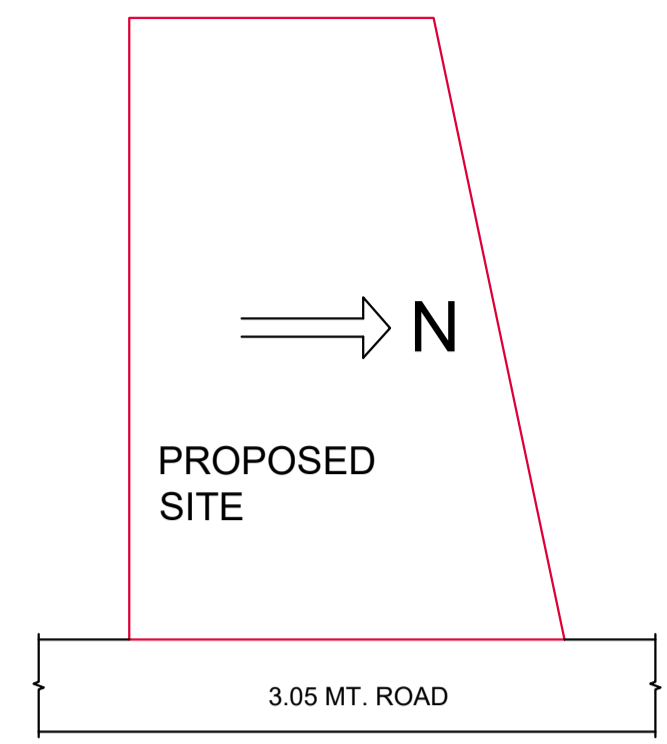
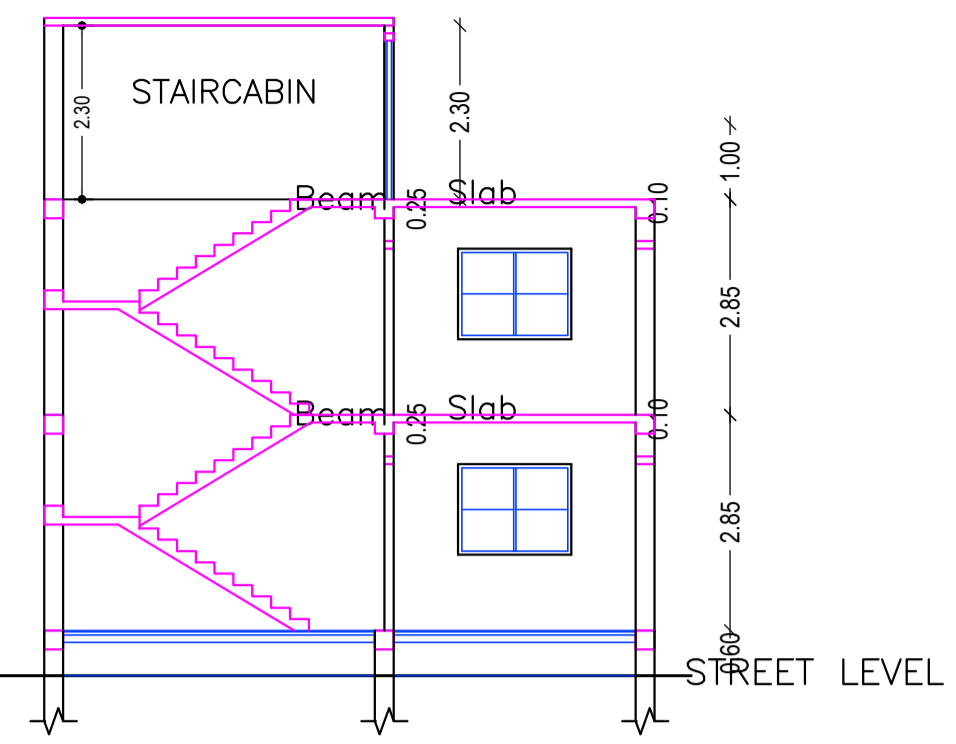
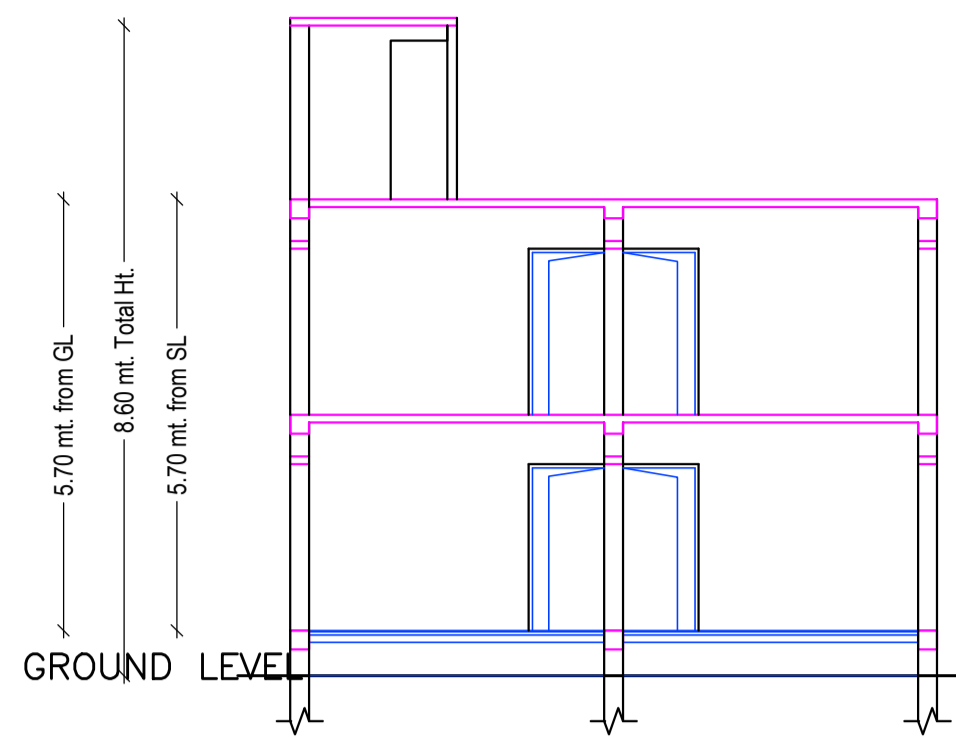
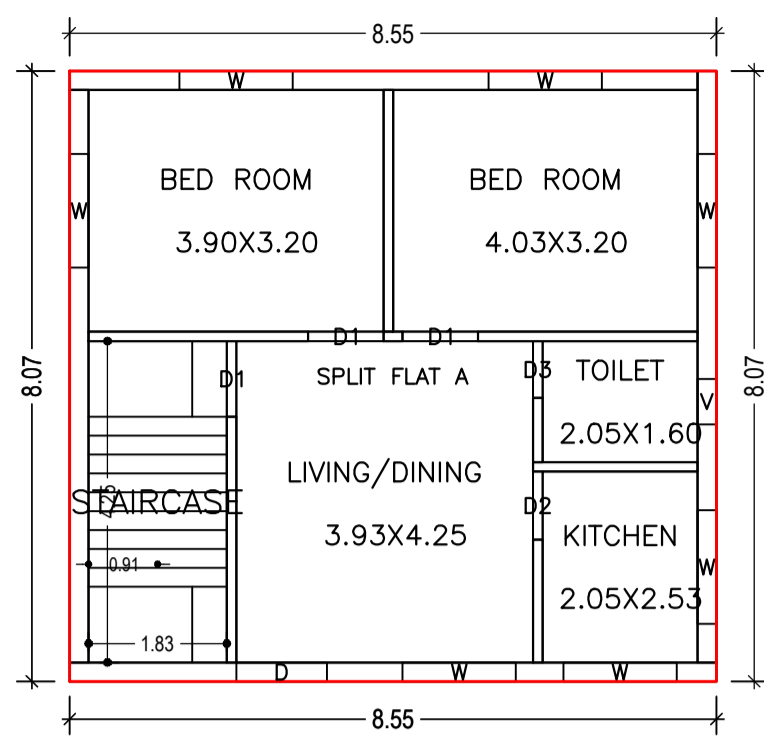

Proposal Basic Information

Proposal File No.	KONPC/BI/0002/W06-0023
Owner Name	JAGDISH PRASAD YADAV
Khata No	169
Plot No	1159
Village Name	Kodarma
Use	Residential
SubUse	Bungalow/ Dwelling / Non Apartment

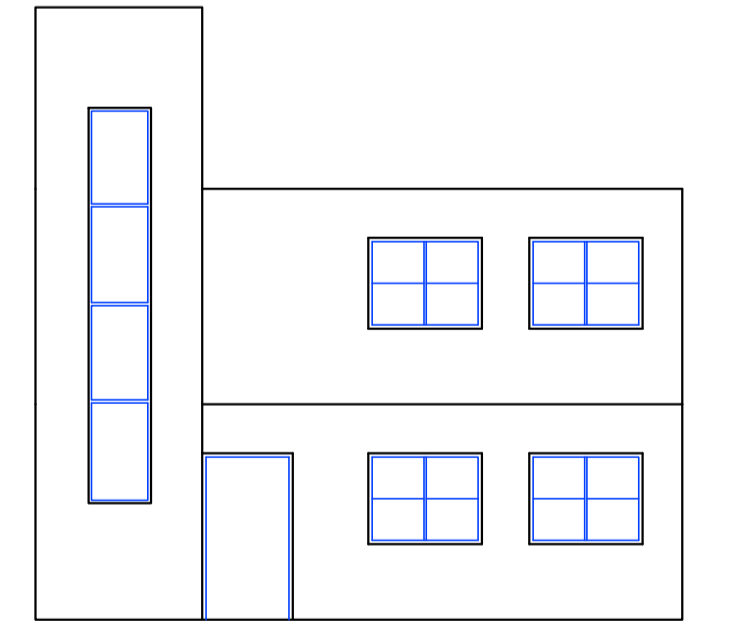
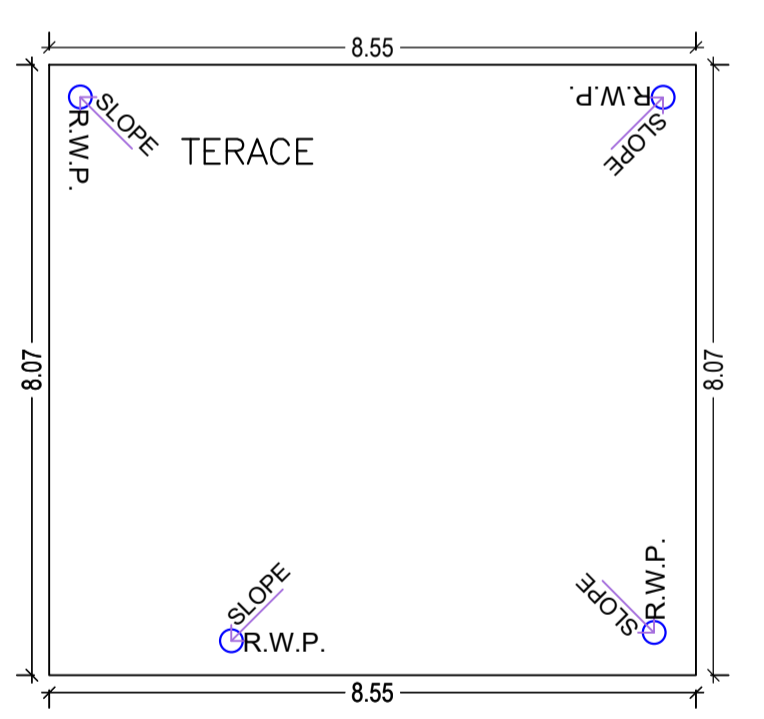
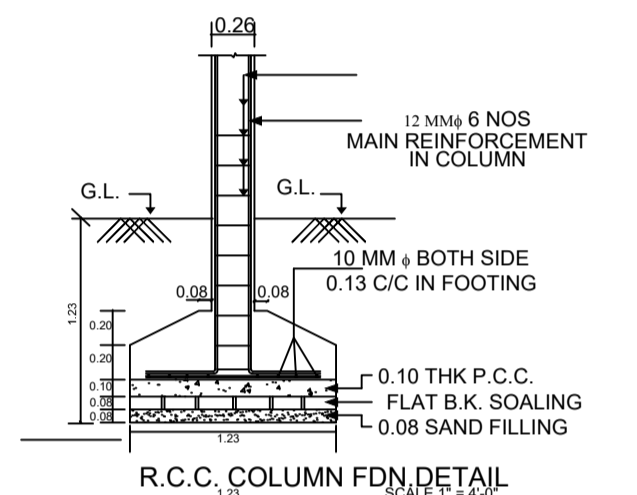
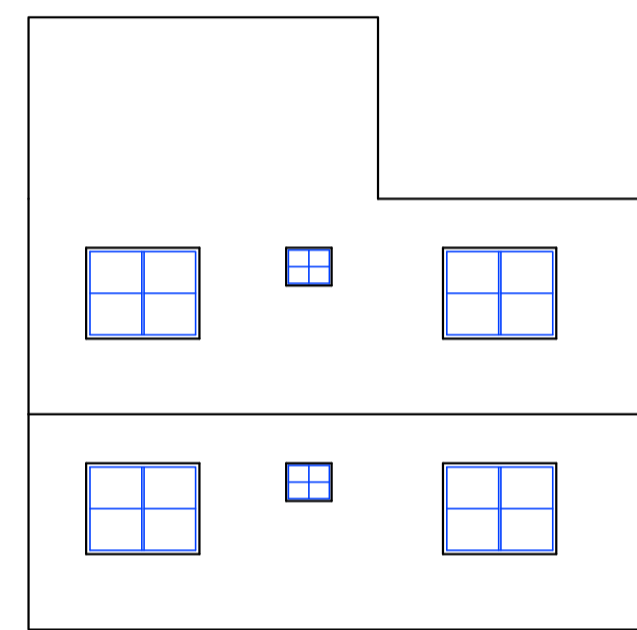
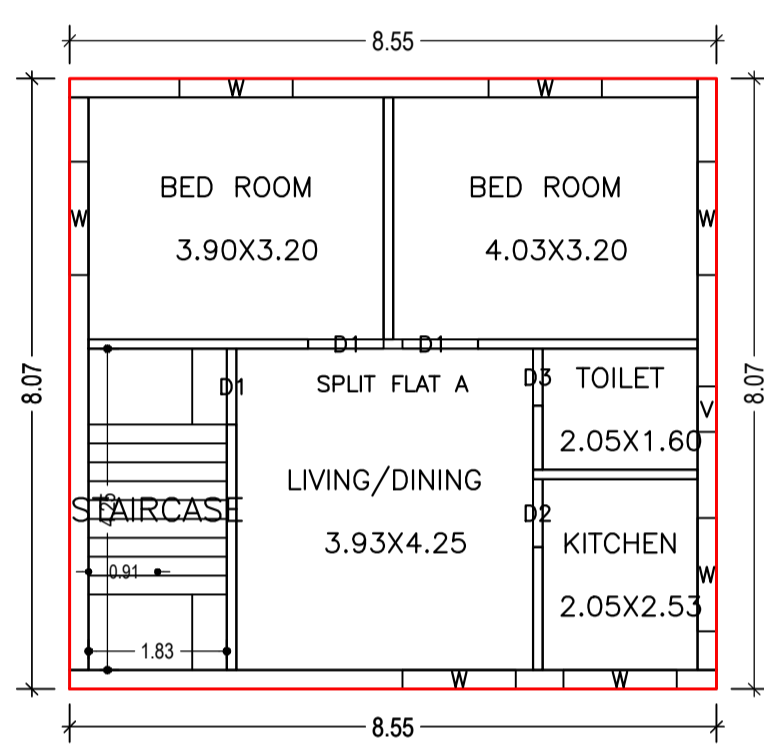
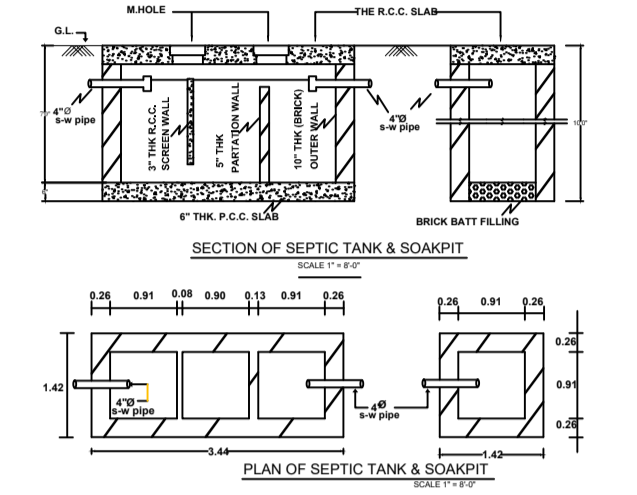

SCHEDULE OF DOOR:

BUILDING NAME	NAME	LENGTH	HEIGHT	NOS
AAA (JAGDISH PD YADAV)	D3	0.75	2.20	02
AAA (JAGDISH PD YADAV)	D2	0.90	2.20	02
AAA (JAGDISH PD YADAV)	D1	1.00	2.20	06
AAA (JAGDISH PD YADAV)	D	1.20	2.20	01

SCHEDULE OF WINDOW/VENTILATION:

BUILDING NAME	NAME	LENGTH	HEIGHT	NOS
AAA (JAGDISH PD YADAV)	V	0.60	0.50	02
AAA (JAGDISH PD YADAV)	W	1.50	1.20	14

UnitBUA Table for Building :AAA (JAGDISH PD YADAV)

FLOOR	Name	UnitBUA Type	UnitBUA Area	Carpet Area	No. of Rooms	No. of Tenement
GROUND FLOOR PLAN	SPLIT FLAT A	FLAT	106.01	102.48	5	1
FIRST FLOOR PLAN	SPLIT FLAT A	FLAT	0.00	0.00	5	0
Total	-	-	106.01	102.48	10	1

Building :AAA (JAGDISH PD YADAV)

Floor Name	Total Built Up Area (Sq.mt.)	Proposed FAR Area (Sq.mt.) Resi.	Total FAR Area (Sq.mt.)	Total Consumed Additional FAR Area (Sq.mt.)	Tnmt (No.)
Ground Floor	69.07	69.07	69.07	69.07	01
First Floor	69.07	69.07	69.07	69.07	00
Terrace Floor	0.00	0.00	0.00	0.00	00
Total :	138.14	138.14	138.14	138.14	01
Total Number of Same Buildings :	1				
Total :	138.14	138.14	138.14	138.14	01

LTP NAME AND SIGNATURE	STRUCTURAL ENG'S NAME AND SIGNATURE	BUILDER NAME AND SIGNATURE	DIGITAL SIGNATURE
Amrendra Kumar KONPC/SUP/0002/2017			