

SITE PLAN
SCALE:1:100

FAR & Tenement Details (Table 4c-1)

Building	No. of Same Bldg	Total Built Up Area (Sq.mt.)	Deductions (Area in Sq.mt.)		Proposed FAR Area (Sq.mt.)	Total FAR Area (Sq.mt.)	Total Consumed Additional FAR Area (Sq.mt.)	Trmnt (No.)
			Lift	Parking				
A (RAVINDRA KUMAR SINGH)	1	337.26	3.80	46.45	287.01	287.01	287.01	01
Grand Total :	1	337.26	3.80	46.45	287.01	287.01	287.01	01

Proposal Basic Information

Proposal File No.	KONPC/BI/0020/W02/2023
Owner Name	RAVINDRA KUMAR SINGH
Khata No	1
Plot No	124
Village Name	Baghitad
Use	Residential
SubUse	Bungalow/ Dwelling / Non Apartment

AREA STATEMENT	VERSION NO. : 1.0.66
KODERMA NAGAR PANCHAYAT	VERSION DATE: 16/10/2020
PROJECT DETAIL:	
Region: JHARKHAND URBAN LOCAL BODIES	Plot Use: Residential
District: KODERMA	Plot SubUse: Bungalow/ Dwelling / Non Apartment
Authority: KODERMA NAGAR PANCHAYAT	PlotNearbyReligiousStructure: NA
Inward No: KONPC/BI/0020/W02/2023	Plot/SubPlot No: 124
Application Type: General Proposal	North: -
Project Type: Building Permission	South: Road Width - 6.10 MTR WIDE MAIN ROAD Access Road
Nature of Development: New	East: -
Location of Development Area: Old Area	West: -
AREA DETAILS:	
AREA OF PLOT (Minimum)	(A) 183.57
NET AREA OF PLOT(Gross Plot Area - Deduction from Gross Plot area)	(A-Deductions) 183.57
Deduction for Balance Plot Area(from Gross Plot Area)	
Common Plot	25.28
Total	25.28
BALANCE AREA OF PLOT(Net Plot Area - Recreational/Amenity space)	(A-Deductions) 158.29
PLOT AREA FOR COVERAGE(Net Plot Area)	(A-Deductions) 183.57
Plot Area for FAR (Net Plot Area + Road Widening Area)	(A-Deductions) 183.57
COVERAGE CHECK	
Permissible Coverage area (70.00 %)	128.50
Proposed Coverage Area (61.24 %)	112.42
Total Prop. Coverage Area (61.24 %)	112.42
Balance coverage area (8.76 %)	16.08
FAR CHECK	
Perm. FAR Area (2.000)	367.14
Total Perm. FAR area	367.14
Residential FAR	287.01
Proposed FAR Area	287.01
Total Proposed FAR Area	287.01
Consumed FAR (Factor)	1.56
Balance FAR Area	80.13
BUILT UP AREA CHECK	
Total Proposed BuiltUp Area	337.26
ARCHITECT (Regd)	Anil Kumar Singh
ENGINEER (Regd)	
SUPERVISOR (Regd)	
OWNER (Regd)	RAVINDRA KUMAR SINGH
DEVELOPMENT AUTHORITY	LOCAL BODY

COLOR INDEX	
PLOT BOUNDARY	Black
ABUTTING ROAD	Green
PROPOSED CONSTRUCTION	Red
COMMON PLOT	Yellow
ROAD WIDENING AREA	Blue
EXISTING (To be retained)	Light Blue
EXISTING (To be demolished)	Light Yellow

Buildingwise Floor FAR Details

Floor Name	Building Name		Total	
	Proposed Built Up Area (Sq.mt.)	Proposed FAR Area (Sq.mt.)	Total Proposed Built Up Area (Sq.mt.)	Total FAR Area (Sq.mt.)
Ground Floor	112.42	62.17	112.42	62.17
First Floor	112.42	112.42	112.42	112.42
Second Floor	112.42	112.42	112.42	112.42
Terrace Floor	0.00	0.00	0.00	0.00
Total :	337.26	287.01	337.26	287.01

Building USE/SUBUSE Details

Building Name	Building Use	Building SubUse	Building Structure
A (RAVINDRA KUMAR SINGH)	Residential	Bungalow/ Dwelling / Non Apartment	Non-Highrise

LTP NAME AND SIGNATURE	STRUCTURAL ENG'S NAME AND SIGNATURE	BUILDER NAME AND SIGNATURE	DIGITAL SIGNATURE
Anil Kumar Singh KONPC/ENG/001/2017			

Proposal Basic Information	
Proposal File No.	KONPC/BI/0020/W02/2023
Owner Name	RAVINDRA KUMAR SINGH
Khata No	1
Plot No	124
Village Name	Baghitad
Use	Residential
SubUse	Bungalow/ Dwelling / Non Apartment

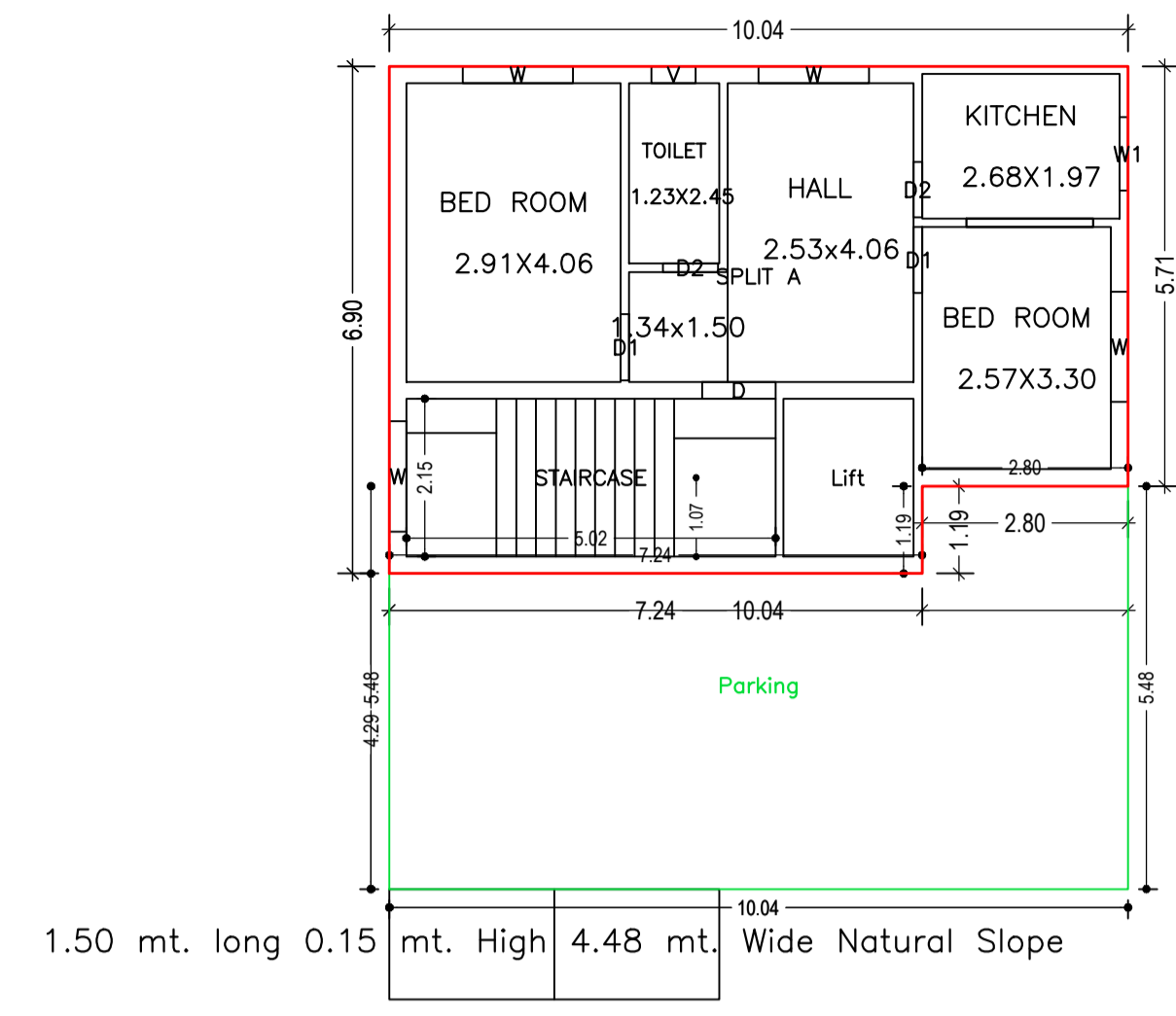

GROUND FLOOR PLAN (Proposed) (SCALE 1:100)

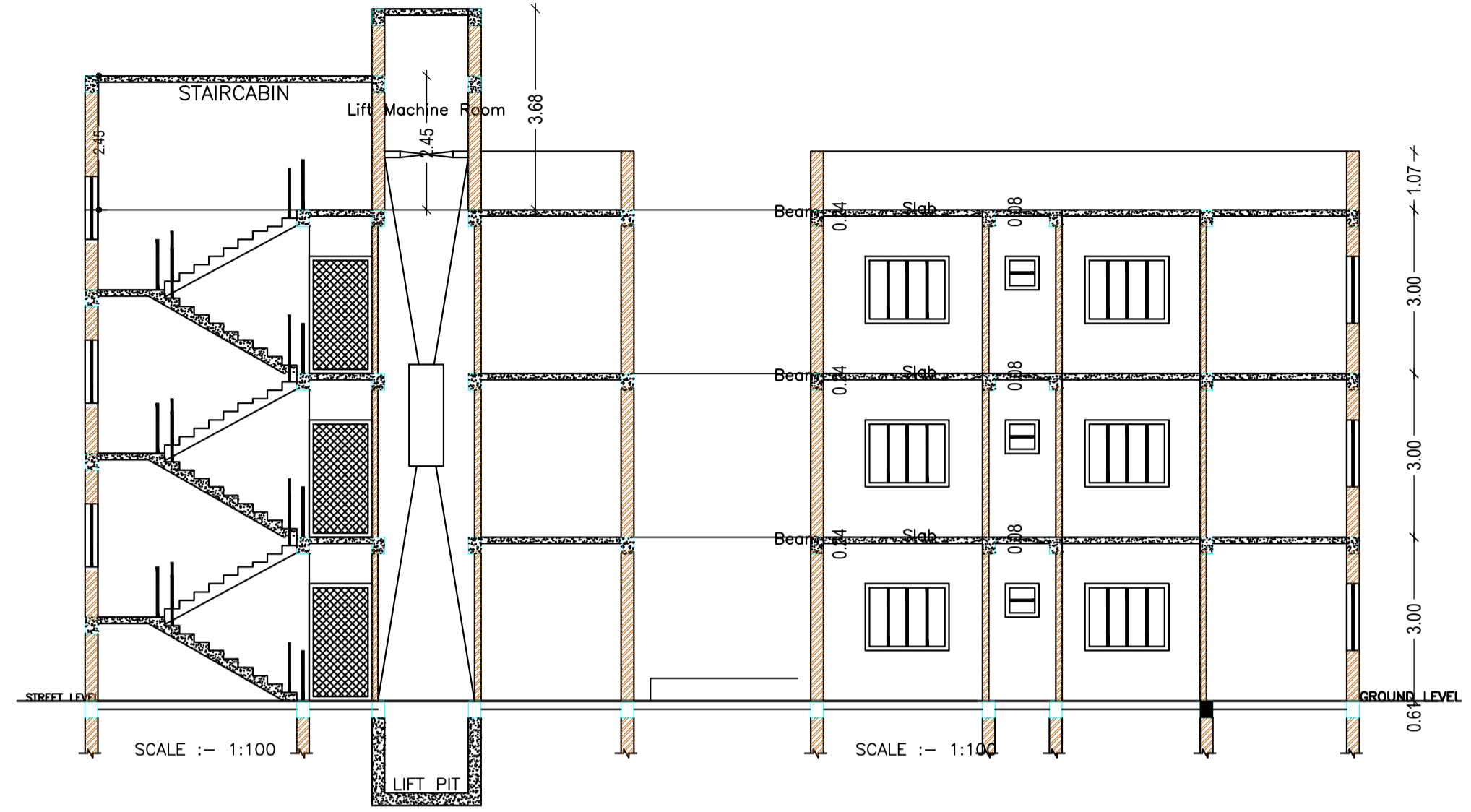

SCALE :- 1:100

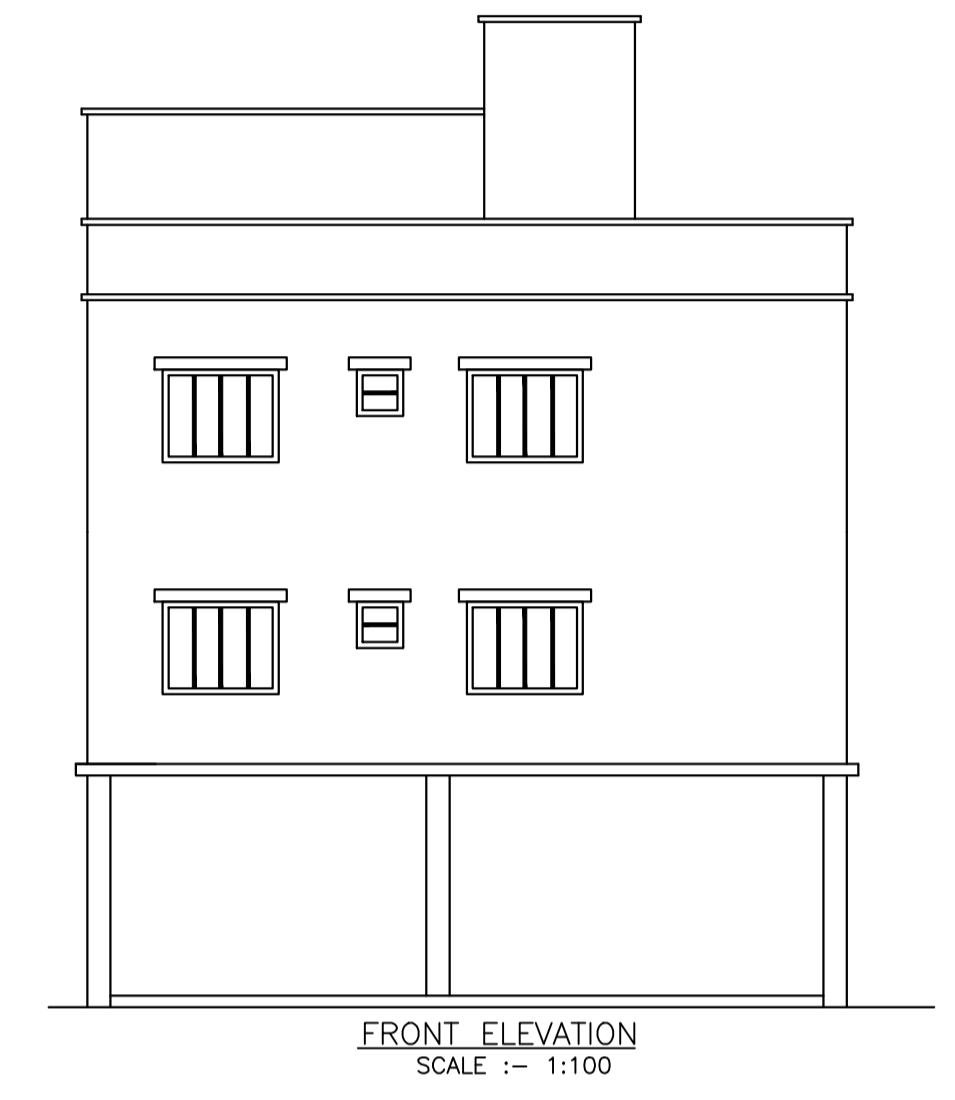

FRONT ELEVATION (SCALE :- 1:100)

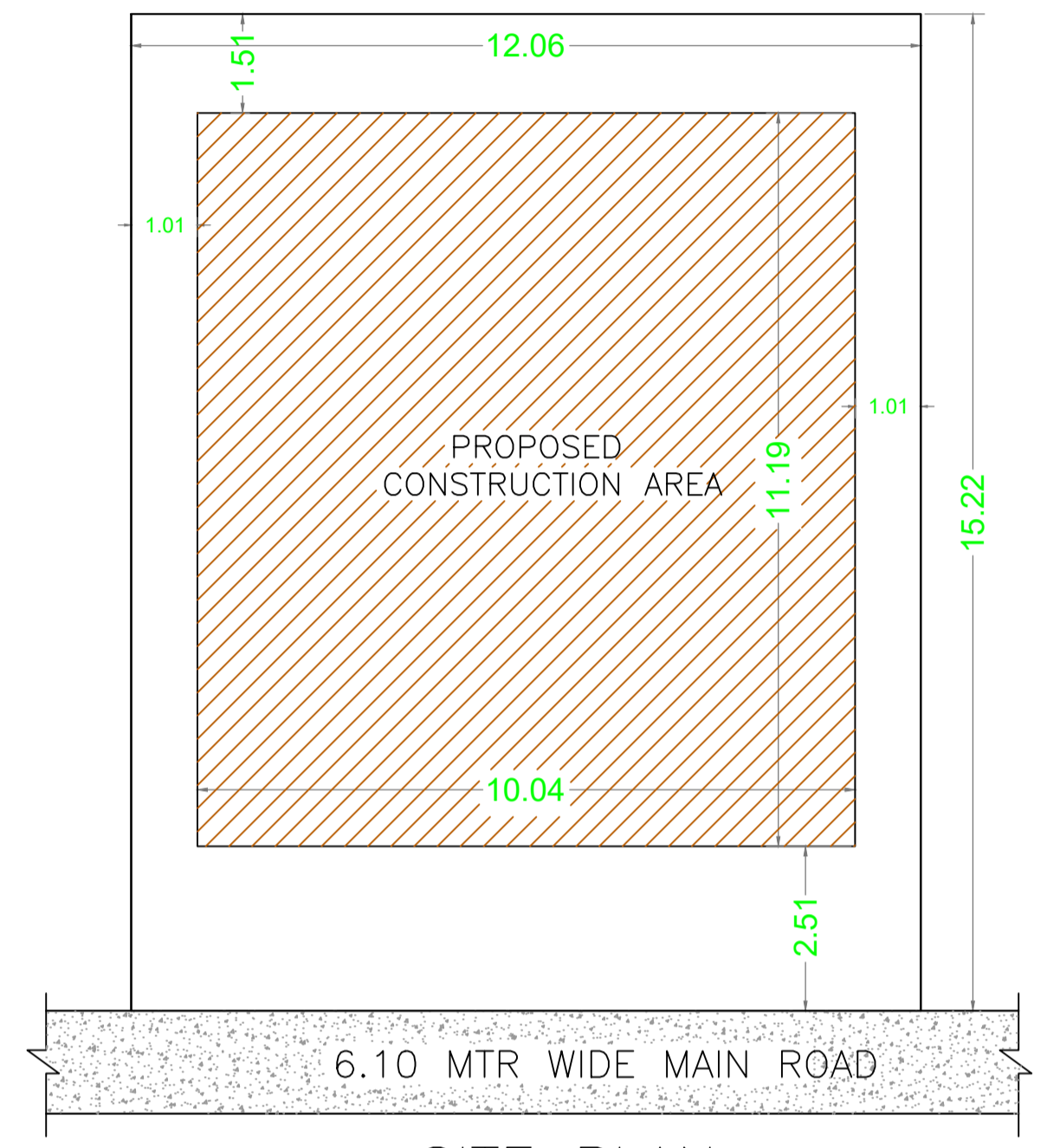

SITE PLAN (SCALE:1:100)

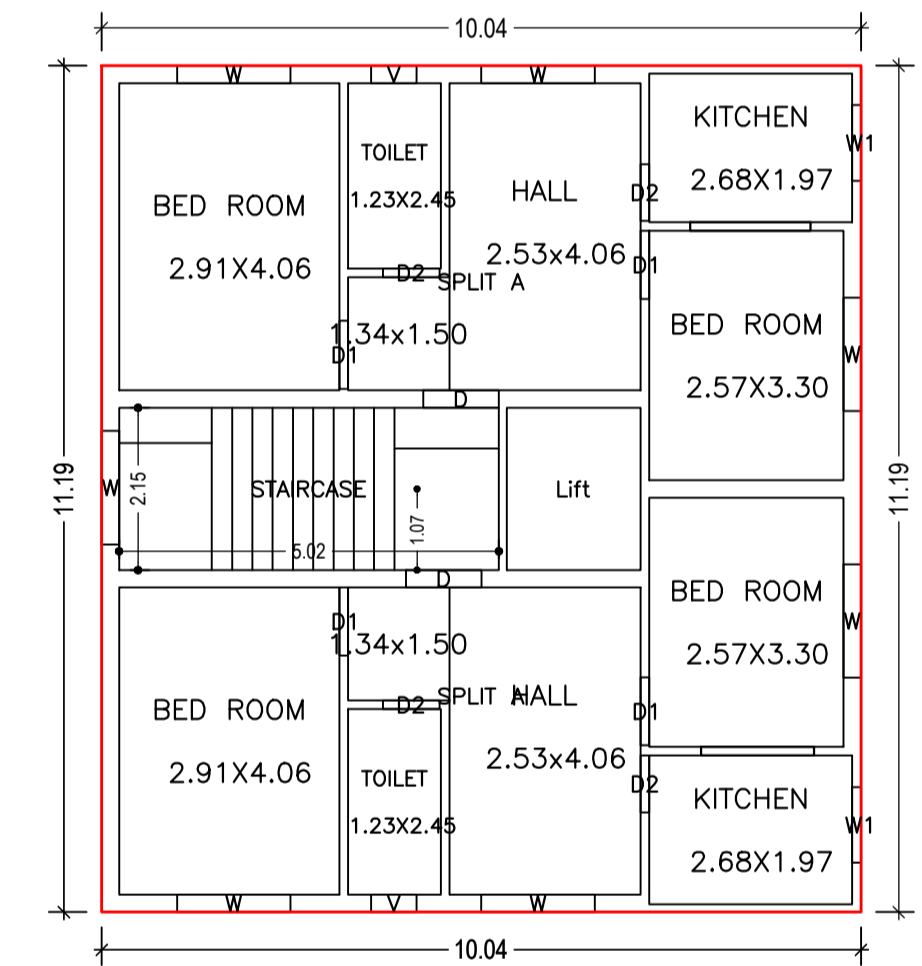

TYPICAL - 1 & 2 FLOOR PLAN (Proposed) (SCALE 1:100)

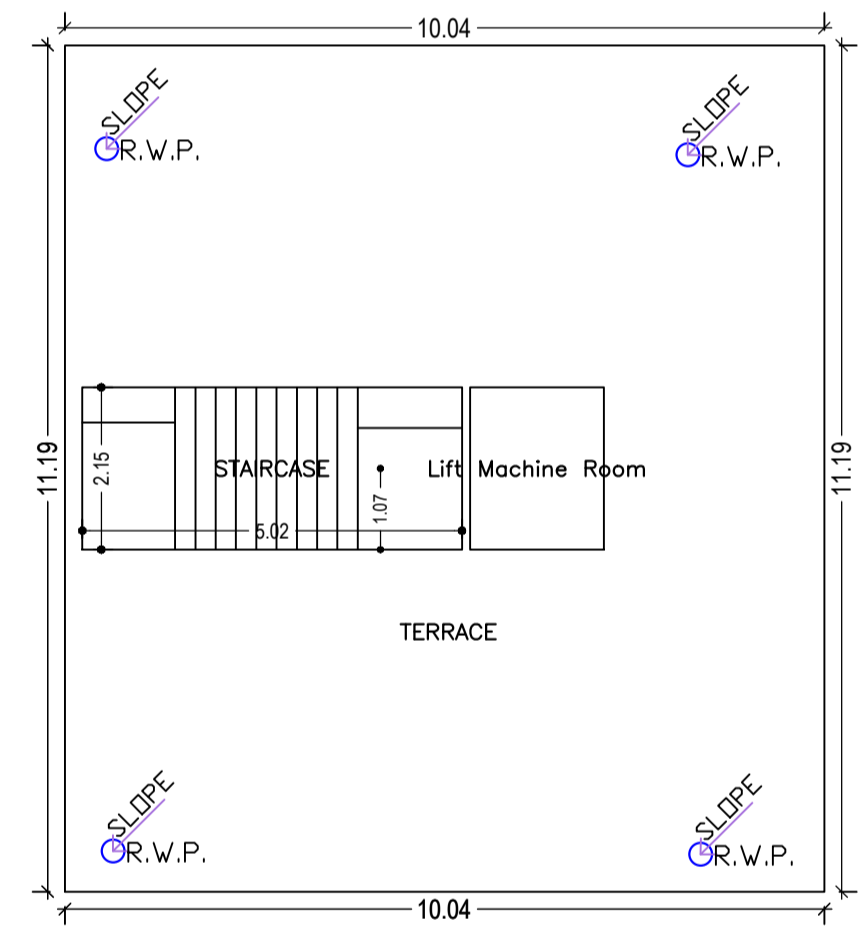

TERRACE FLOOR PLAN (SCALE 1:100)

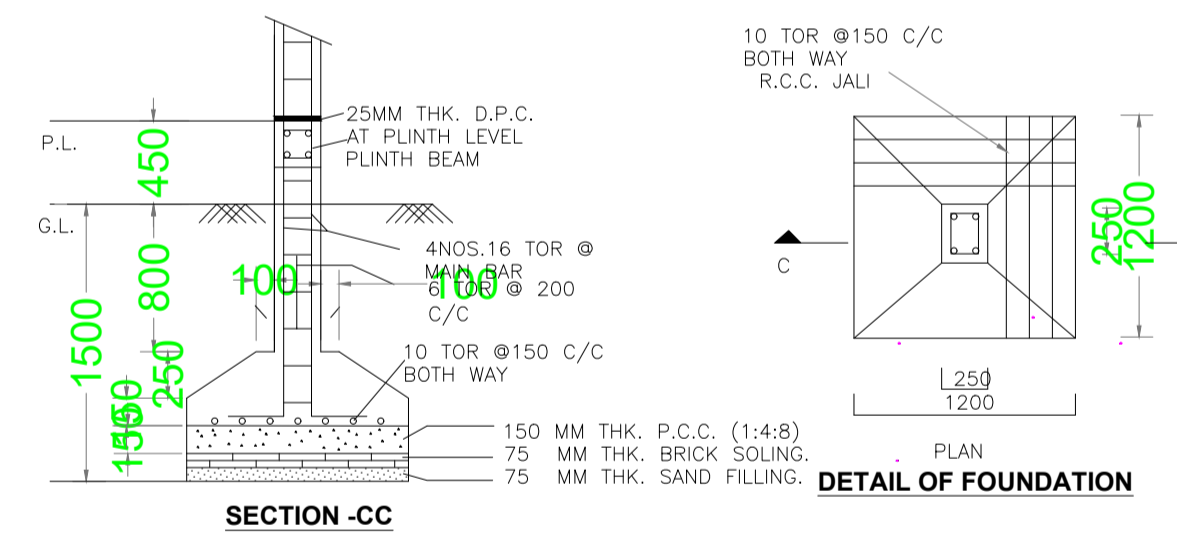

DETAIL OF FOUNDATION

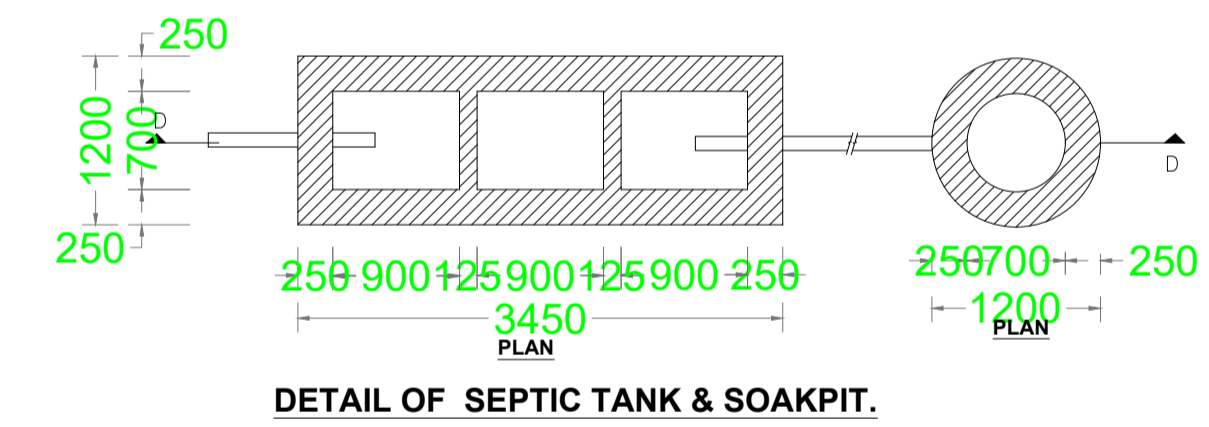

DETAIL OF SEPTIC TANK & SOAKPIT.

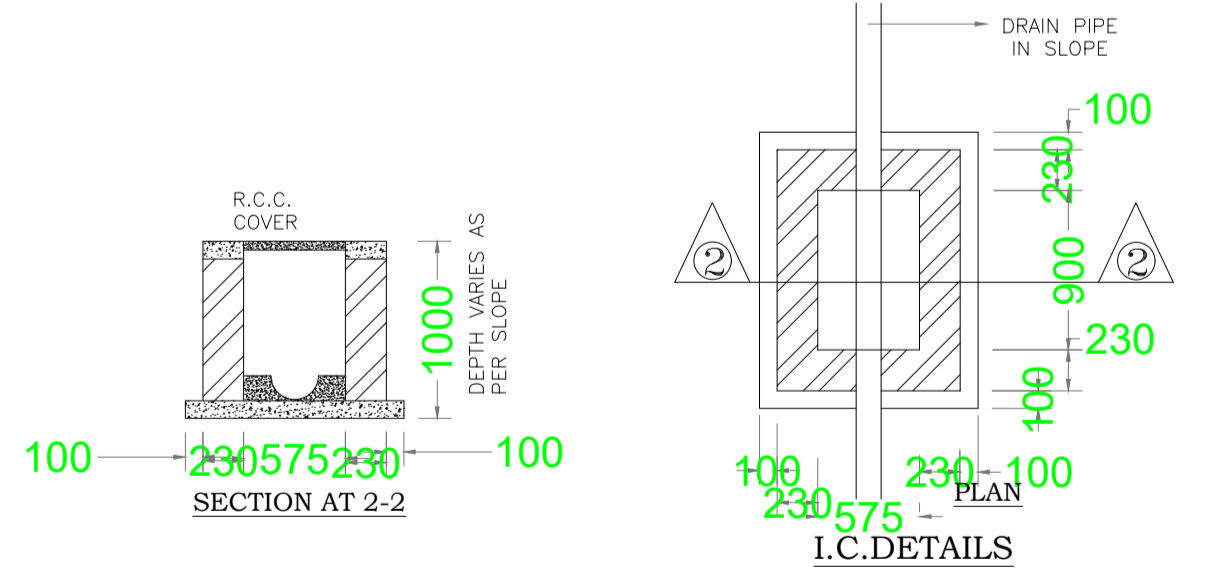

I.C. DETAILS

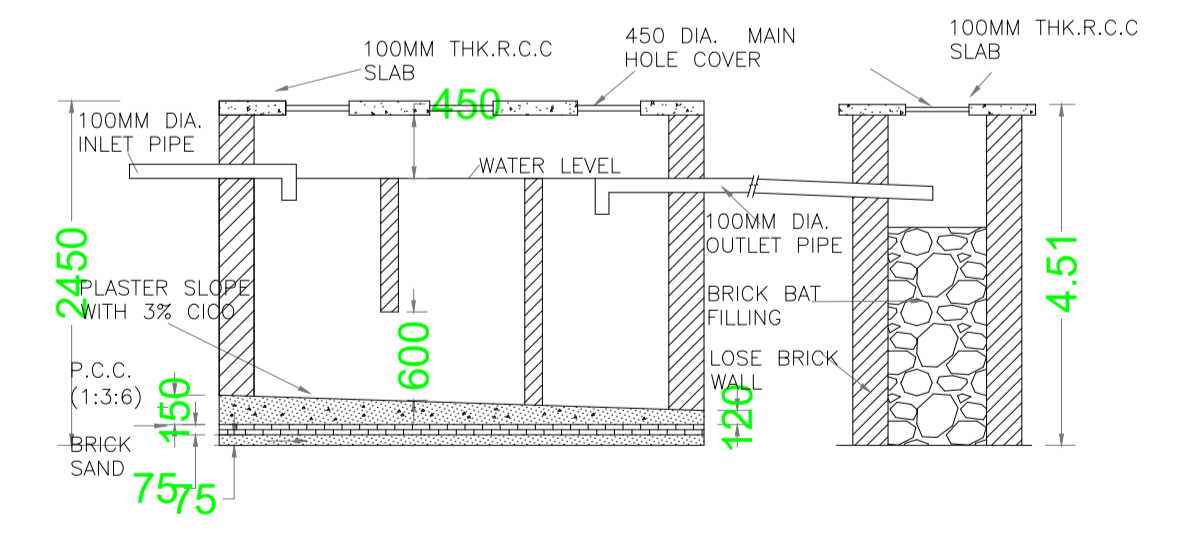

SIDE ELEVATION (SCALE :- 1:100)

ROOF FLOOR LVL +9.15 MTR
SECOND FLOOR LVL +6.15 MTR
FIRST FLOOR LVL +3.15 MTR
PLINTH FLOOR LVL +0.15 MTR
GROUND FLOOR LVL +0.00 MTR

Building :A (RAVINDRA KUMAR SINGH)

Floor Name	Total Built Up Area (Sq.mt.)	Deductions (Area in Sq.mt.)		Proposed FAR Area (Sq.mt.)	Total FAR Area (Sq.mt.)	Total Consumed Additional FAR Area (Sq.mt.)	Trmt (No.)
		Lift	Parking				
Ground Floor	112.42	3.80	46.45	62.17	62.17	62.17	01
First Floor	112.42	0.00	0.00	112.42	112.42	112.42	00
Second Floor	112.42	0.00	0.00	112.42	112.42	112.42	00
Terrace Floor	0.00	0.00	0.00	0.00	0.00	0.00	00
Total :	337.26	3.80	46.45	287.01	287.01	287.01	01
Total Number of Same Buildings	1						
Total :	337.26	3.80	46.45	287.01	287.01	287.01	01

SCHEDULE OF DOOR:

BUILDING NAME	NAME	LENGTH	HEIGHT	NOS
A (RAVINDRA KUMAR SINGH)	D2	0.75	2.13	10
A (RAVINDRA KUMAR SINGH)	D1	0.90	2.13	10
A (RAVINDRA KUMAR SINGH)	D	1.00	2.13	05

SCHEDULE OF WINDOW/VENTILATION:

BUILDING NAME	NAME	LENGTH	HEIGHT	NOS
A (RAVINDRA KUMAR SINGH)	V	0.60	2.70	05
A (RAVINDRA KUMAR SINGH)	W1	1.00	2.70	05
A (RAVINDRA KUMAR SINGH)	W	1.50	2.70	18

UnitBUA Table for Building :A (RAVINDRA KUMAR SINGH)

FLOOR	Name	UnitBUA Type	UnitBUA Area	Carpet Area	No. of Rooms	No. of Tenement
GROUND FLOOR PLAN	SPLIT A	FLAT	212.73	211.82	5	1
TYPICAL - 1 & 2 FLOOR PLAN	SPLIT A	FLAT	0.00	0.00	5	0
Total:	-	-	212.73	211.82	25	1

LTP NAME AND SIGNATURE	STRUCTURAL ENG'S NAME AND SIGNATURE	BUILDER NAME AND SIGNATURE	DIGITAL SIGNATURE
Anil Kumar Singh KONPC/ENG/0001/2017			

Proposal Basic Information

Proposal File No.	KONPC/BP/0020/W02/2023
Owner Name	RAVINDRA KUMAR SINGH
Khata No	1
Plot No	124
Village Name	Baghitad
Use	Residential
SubUse	Bungalow/ Dwelling / Non Apartment

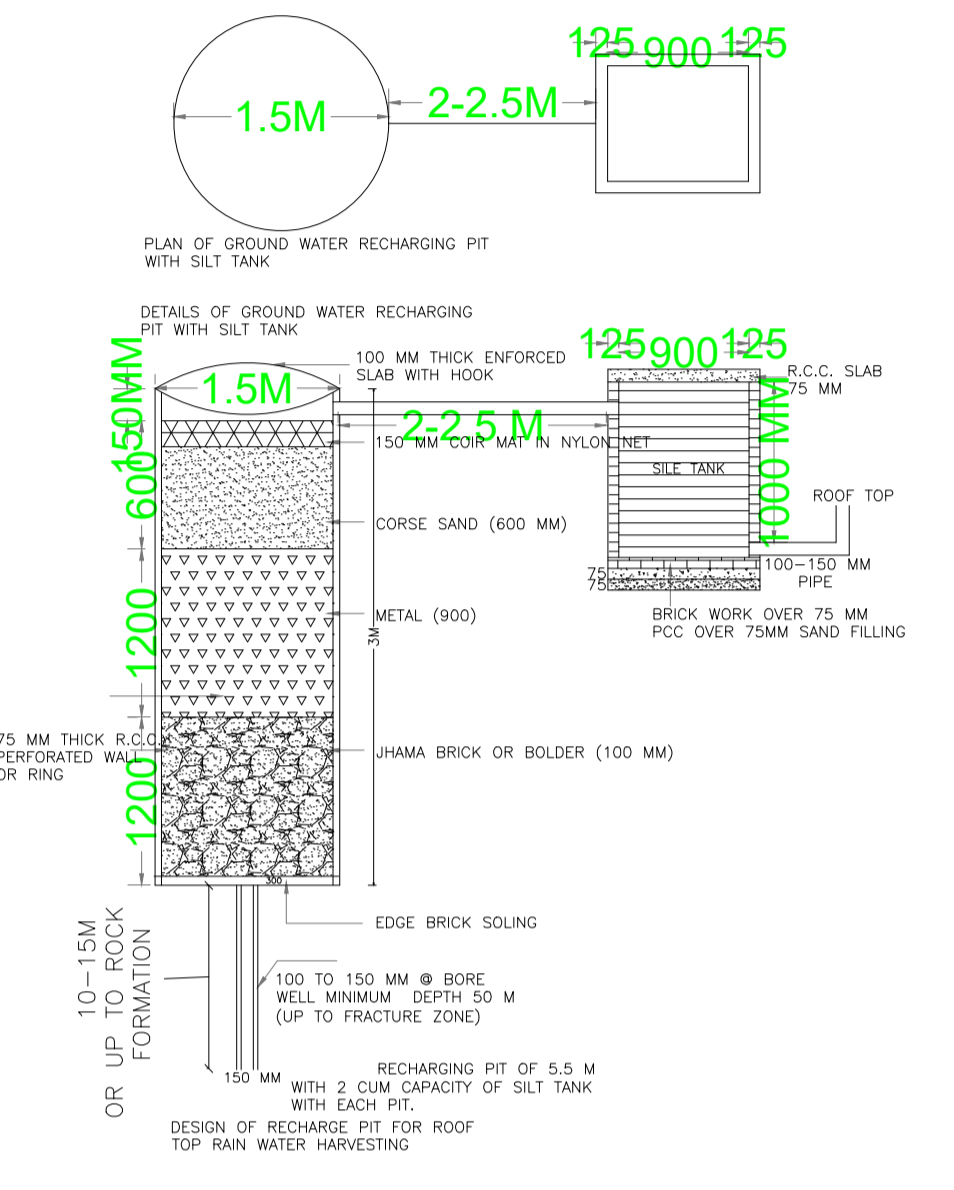

LTP NAME AND SIGNATURE	STRUCTURAL ENG'S NAME AND SIGNATURE	BUILDER NAME AND SIGNATURE	DIGITAL SIGNATURE
Anil Kumar Singh KONPC/ENG/0001/2017			