

SITE PLAN

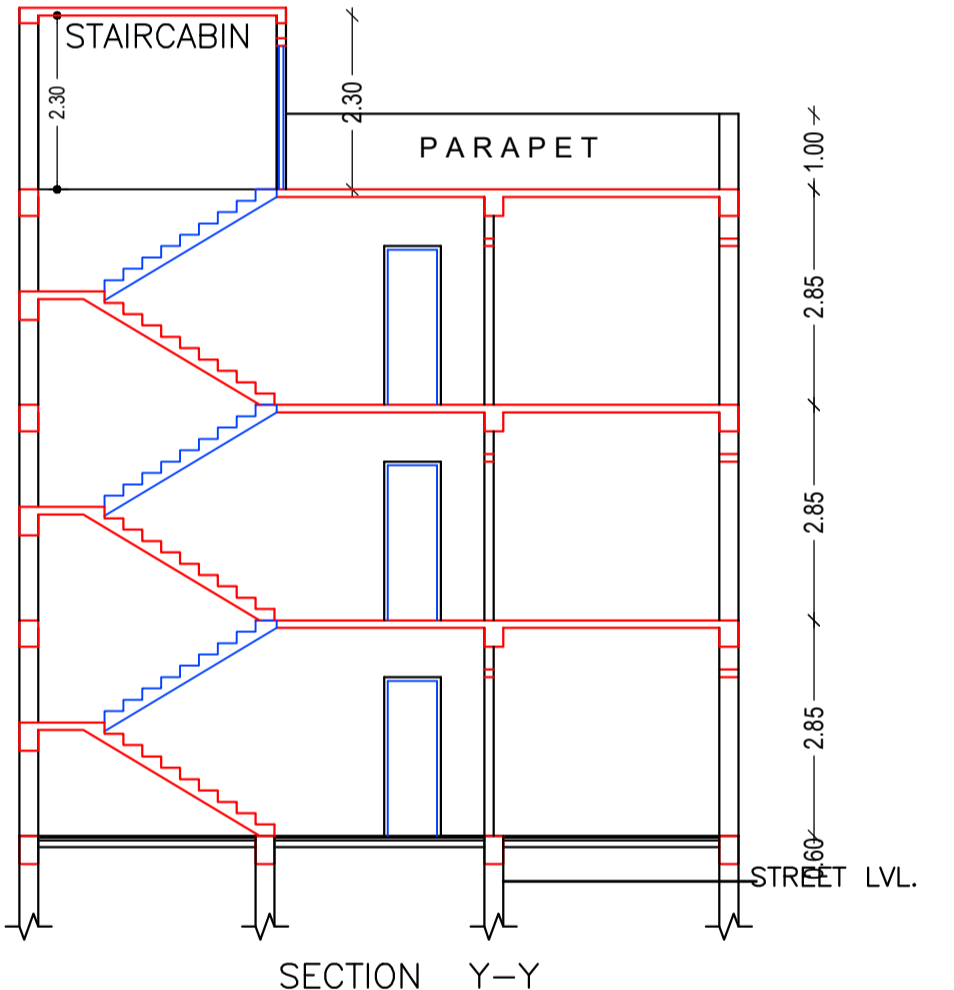
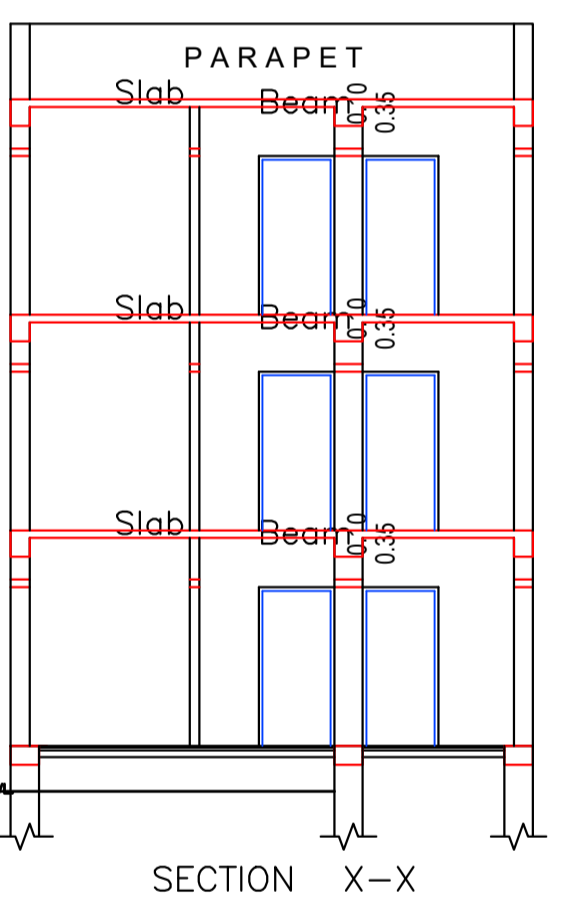
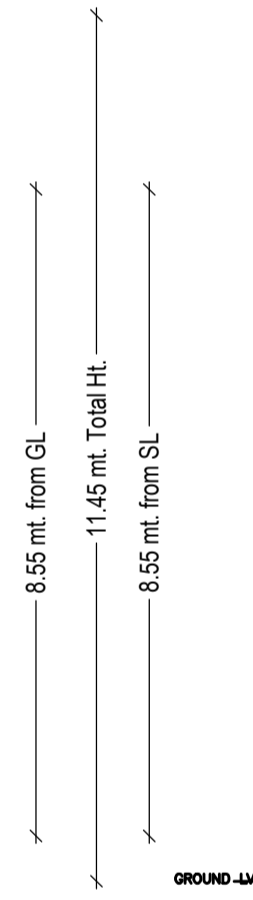
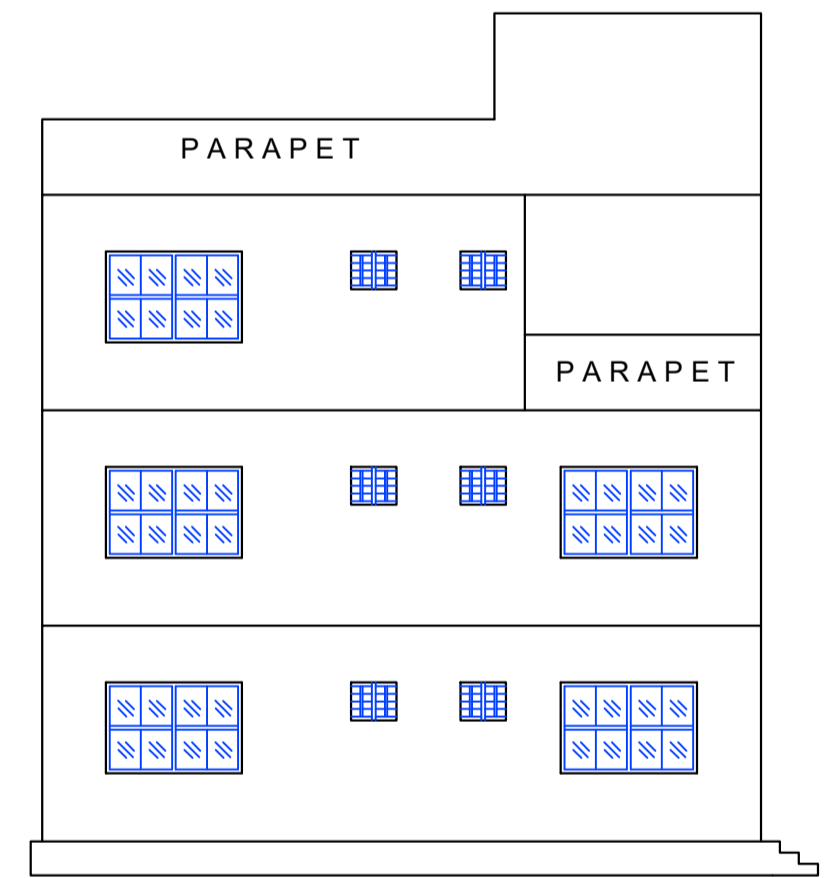
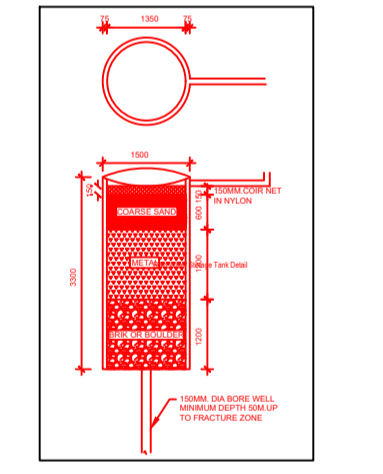
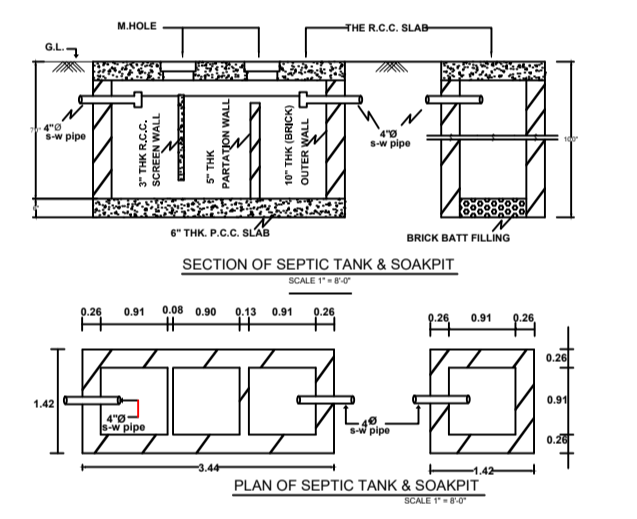
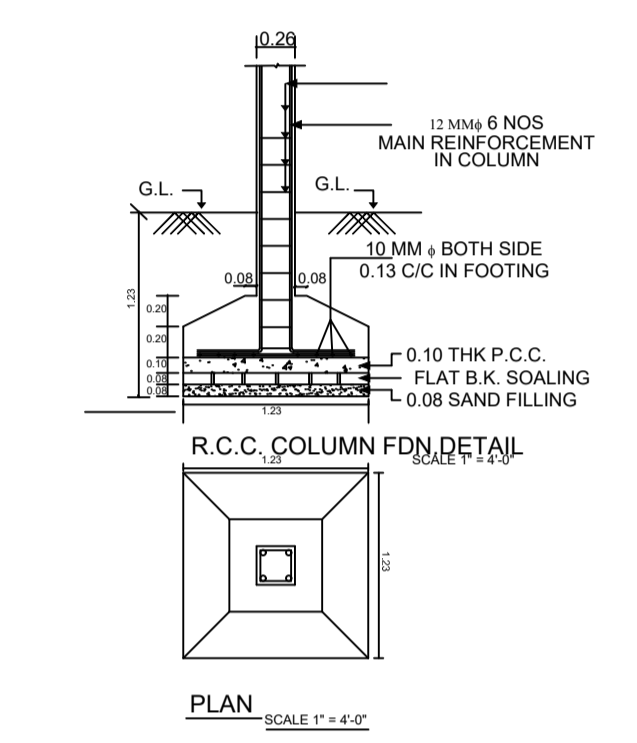
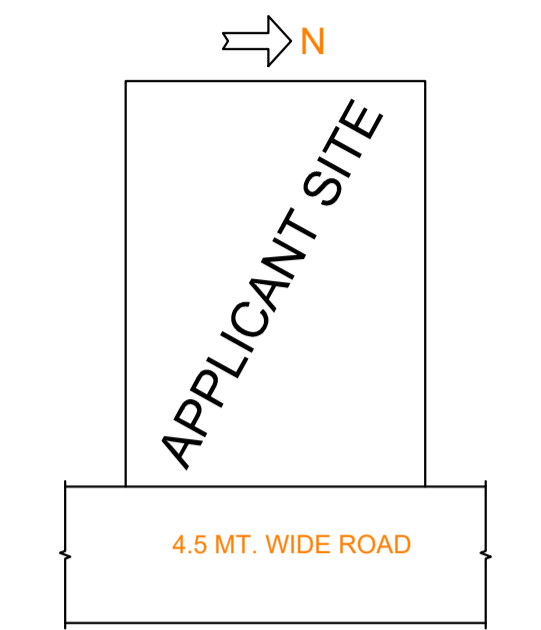
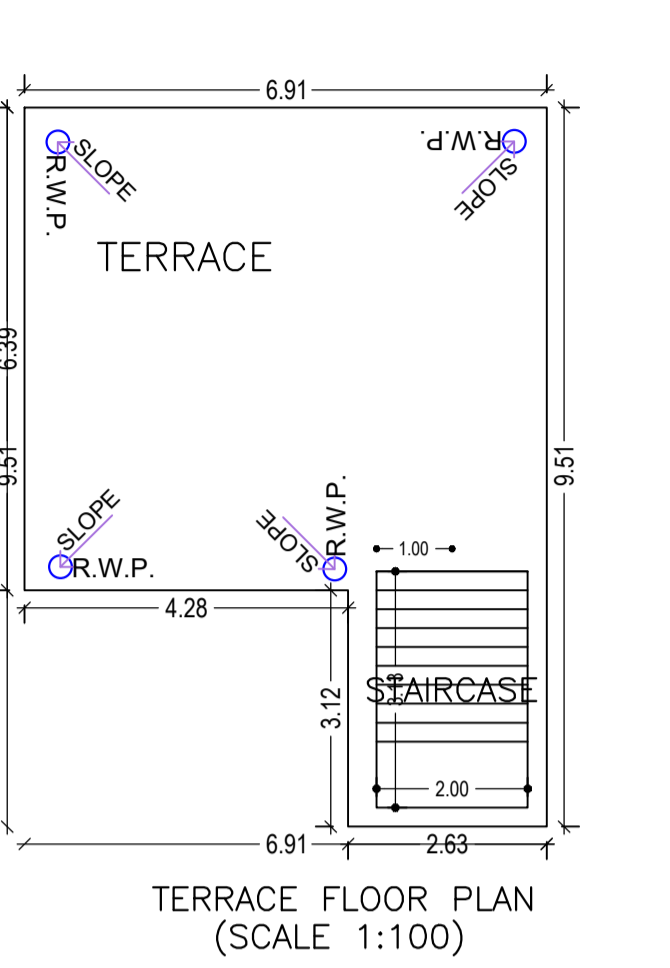
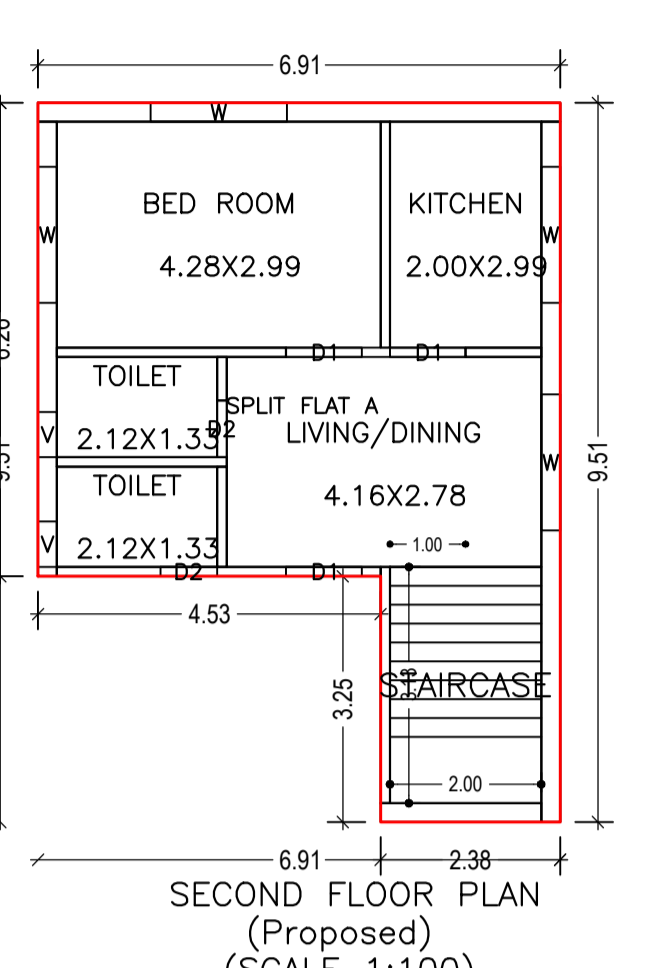
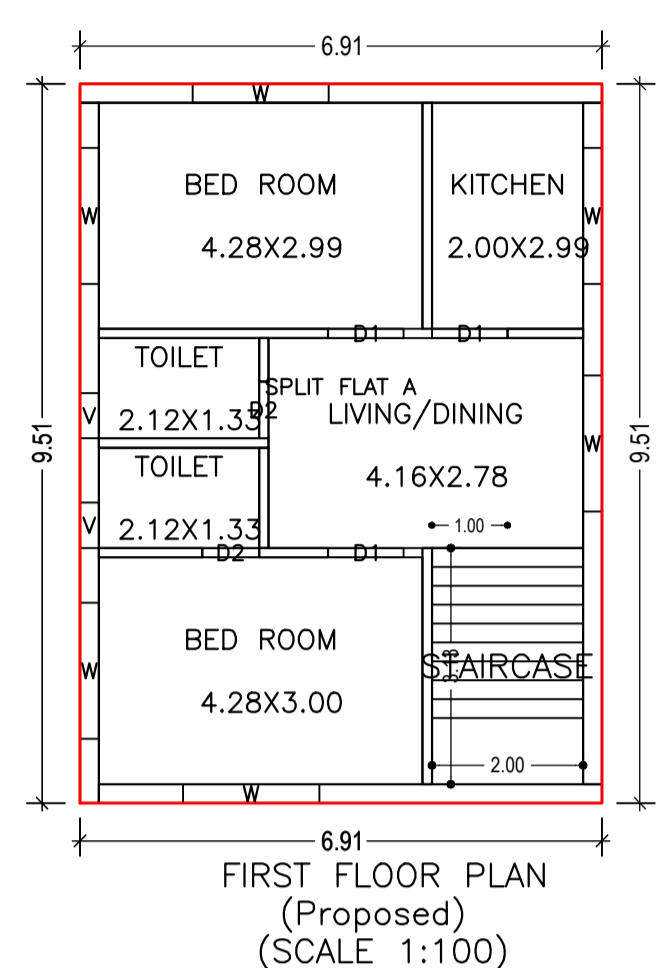
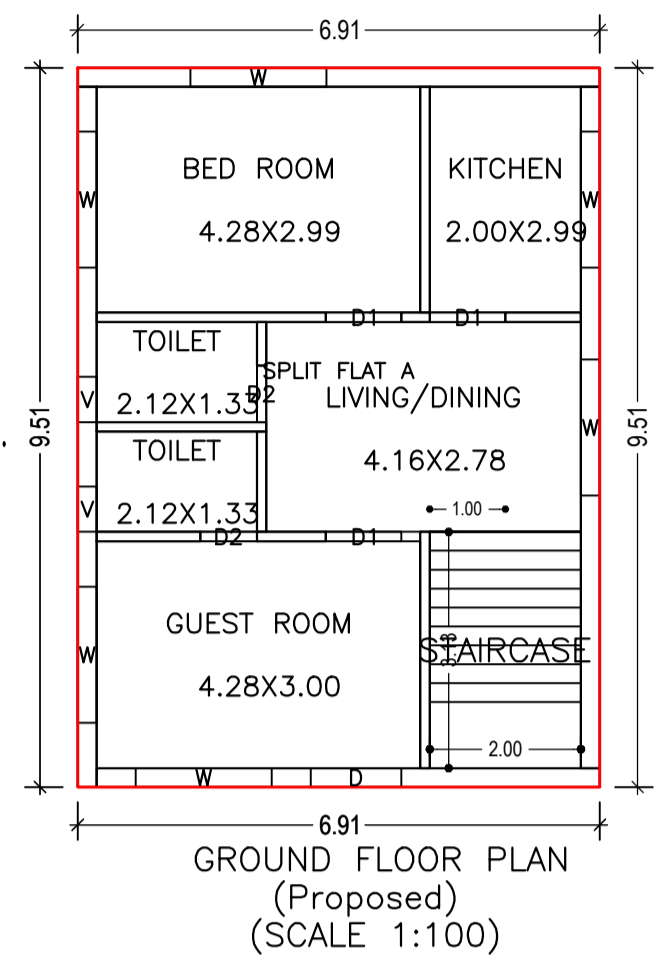

Proposal Basic Information	
Proposal File No.	KONPC/BI/0038/W05/2023
Owner Name	MD.ABBAS
Khata No	169
Plot No	949
Village Name	Kodarma
Use	Residential
SubUse	Bungalow/ Dwelling / Non Apartment

AREA STATEMENT		VERSION NO. : 1.0.66
KODERMA NAGAR PANCHAYAT		VERSION DATE: 16/10/2020
PROJECT DETAIL:		
Region: JHARKHAND URBAN	Plot Use: Residential	
LOCAL BODIES	Plot SubUse: Bungalow/ Dwelling / Non Apartment	
District: KODERMA	PlotNearby/ReligiousStructure: NA	
Authority: KODERMA NAGAR PANCHAYAT	Plot/SubPlot No: 949	
Inward No: KONPC/BI/0038/W05/2023	North: Plot No. - NJ VENDER	
Application Type: General Proposal	South: Plot No. - MD ASHLAM	
Project Type: Building Permission	East: Road Width - 4.5	
Nature of Development: New	West: Plot No. - NEEJ PLOT	
Location of Development Area: Old Area		
AREA DETAILS:		SQ.MT.
AREA OF PLOT (Minimum)	(A)	132.85
NET AREA OF PLOT(Gross Plot Area - Deduction from Gross Plot area)	(A-Deductions)	132.85
Deduction for Balance Plot Area(from Gross Plot Area)		
Common Plot		29.01
Total		29.01
BALANCE AREA OF PLOT(Net Plot Area - Recreational/Amenity space)	(A-Deductions)	103.84
PLOT AREA FOR COVERAGE(Net Plot Area)	(A-Deductions)	132.85
Plot Area for FAR (Net Plot Area + RoadWidening Area)	(A-Deductions)	132.85
COVERAGE CHECK		
Permissible Coverage area (70.00 %)		93.00
Proposed Coverage Area (49.44 %)		65.68
Total Prop. Coverage Area (49.44 %)		65.68
Balance coverage area (20.56 %)		27.32
FAR CHECK		
Perm. FAR Area (1.500)		199.28
Total Perm. FAR area		199.28
Residential FAR		182.32
Proposed FAR Area		182.32
Total Proposed FAR Area		182.32
Consumed FAR (Factor)		1.37
Balance FAR Area		16.96
BUILT UP AREA CHECK		
Total Proposed BuiltUp Area		182.32
ARCHITECT (Regd)	Amrendra Kumar	
ENGINEER (Regd)		
SUPERVISOR (Regd)		
OWNER (Regd)	MD.ABBAS	
DEVELOPMENT AUTHORITY		LOCAL BODY

Building :AAA (MD ABBAS)

Floor Name	Total Built Up Area (Sq.mt.)	Proposed FAR Area (Sq.mt.) Resi.	Total FAR Area (Sq.mt.)	Total Consumed Additional FAR Area (Sq.mt.)	Tnmt (No.)
Ground Floor	65.68	65.68	65.68	65.68	01
First Floor	65.68	65.68	65.68	65.68	00
Second Floor	50.96	50.96	50.96	50.96	00
Terrace Floor	0.00	0.00	0.00	0.00	00
Total:	182.32	182.32	182.32	182.32	01
Total Number of Same Buildings	1				
Total:	182.32	182.32	182.32	182.32	01

Building USE/SUBUSE Details

Building Name	Building Use	Building SubUse	Building Structure
AAA (MD ABBAS)	Residential	Bungalow/ Dwelling / Non Apartment	Non-Highrise

COLOR INDEX

PLOT BOUNDARY	Black
ABUTTING ROAD	Red
PROPOSED CONSTRUCTION	Green
COMMON PLOT	Blue
ROAD WIDENING AREA	Yellow
EXISTING (To be retained)	Orange
EXISTING (To be demolished)	Grey

Buildingwise Floor FAR Details

Floor Name	Building Name		Total	
	Proposed Built Up Area (Sq.mt.)	Proposed FAR Area (Sq.mt.)	Total Proposed Built Up Area (Sq.mt.)	Total FAR Area (Sq.mt.)
Ground Floor	65.68	65.68	65.68	65.68
First Floor	65.68	65.68	65.68	65.68
Second Floor	50.96	50.96	50.96	50.96
Terrace Floor	0.00	0.00	0.00	0.00
Total:	182.32	182.32	182.32	182.32

FAR & Tenement Details (Table 4c-1)

Building	No. of Same Bldg	Total Built Up Area (Sq.mt.)	Proposed FAR Area (Sq.mt.) Resi.	Total FAR Area (Sq.mt.)	Total Consumed Additional FAR Area (Sq.mt.)	Tnmt (No.)
AAA (MD ABBAS)	1	182.32	182.32	182.32	182.32	01
Grand Total:	1	182.32	182.32	182.32	182.32	01

SCHEDULE OF DOOR:

BUILDING NAME	NAME	LENGTH	HEIGHT	NOS
AAA (MD ABBAS)	D2	0.75	2.10	06
AAA (MD ABBAS)	D1	1.00	2.10	09
AAA (MD ABBAS)	D	1.20	2.10	01

SCHEDULE OF WINDOW/VENTILATION:

BUILDING NAME	NAME	LENGTH	HEIGHT	NOS
AAA (MD ABBAS)	V	0.80	0.50	06
AAA (MD ABBAS)	W	1.80	1.20	16

UnitBUA Table for Building :AAA (MD ABBAS)

FLOOR	Name	UnitBUA Type	UnitBUA Area	Carpet Area	No. of Rooms	No. of Tenement
GROUND FLOOR PLAN	SPLIT FLAT A	FLAT	140.65	135.07	6	1
FIRST FLOOR PLAN	SPLIT FLAT A	FLAT	0.00	0.00	6	0
SECOND FLOOR PLAN	SPLIT FLAT A	FLAT	0.00	0.00	5	0
Total:	-	-	140.65	135.07	17	1

LTP NAME AND SIGNATURE	STRUCTURAL ENG'S NAME AND SIGNATURE	BUILDER NAME AND SIGNATURE	DIGITAL SIGNATURE
Amrendra Kumar KONPC/SUP/002/2017			