

Project Title :SMT.MANORMA PRASAD

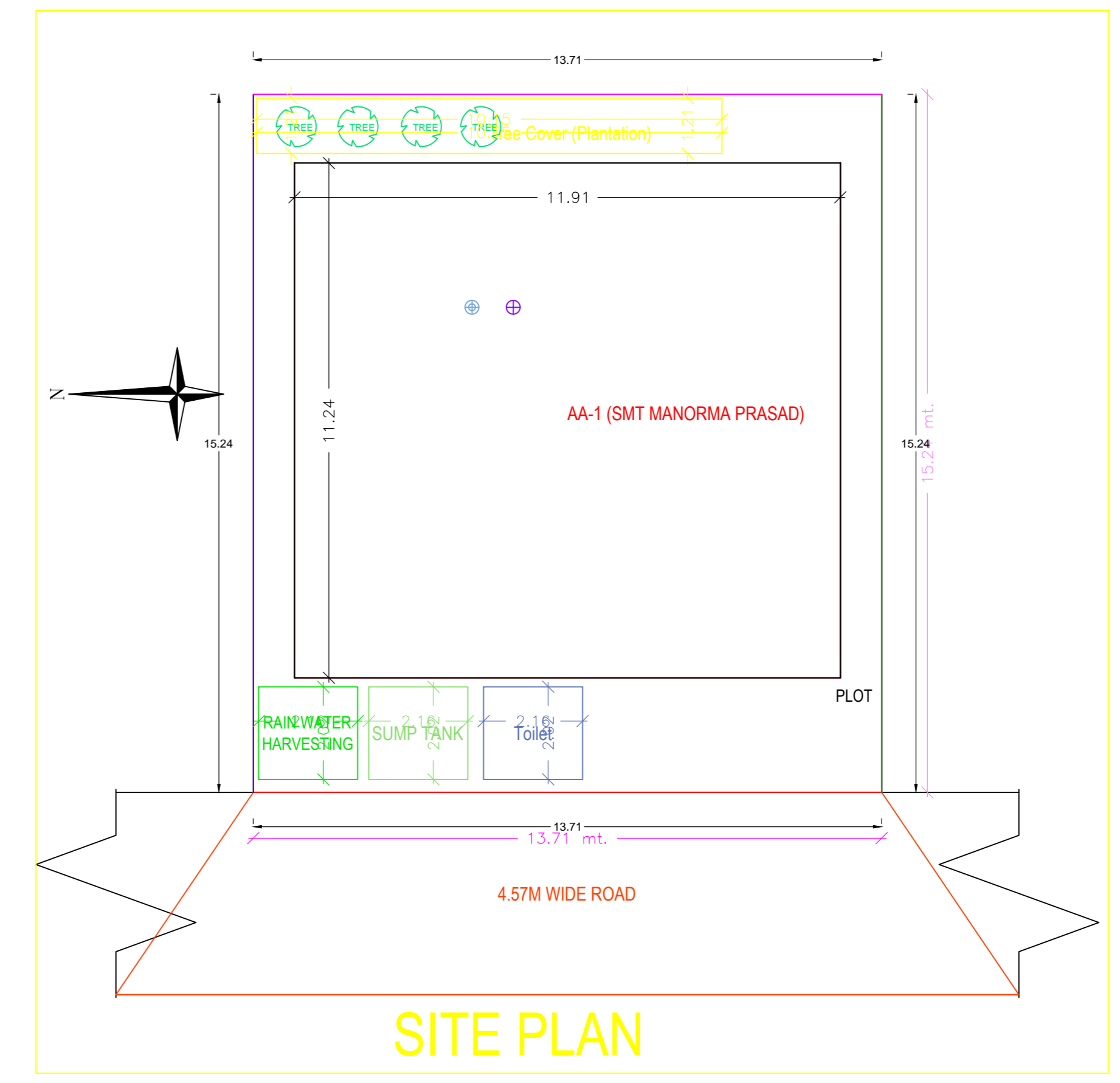
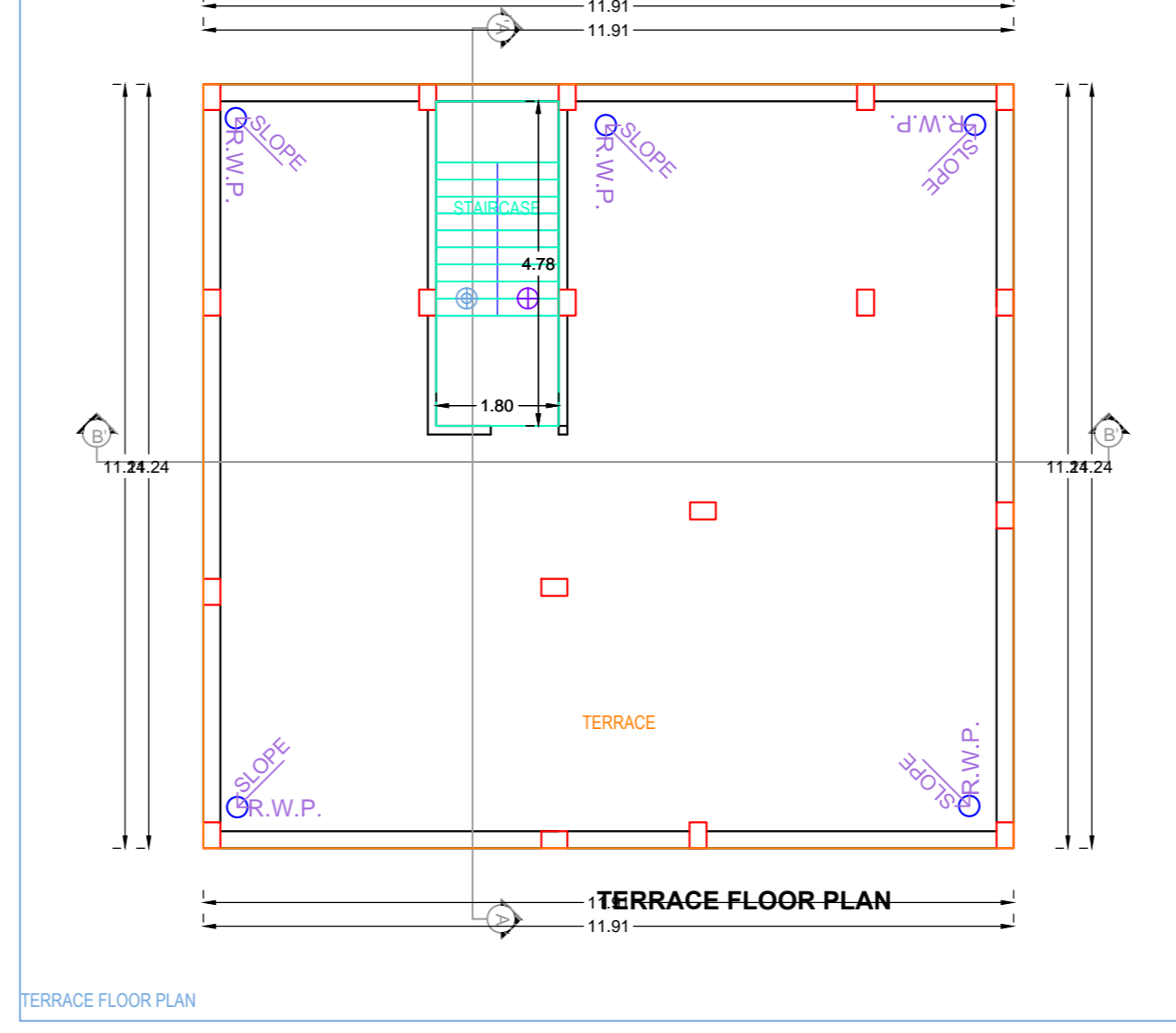
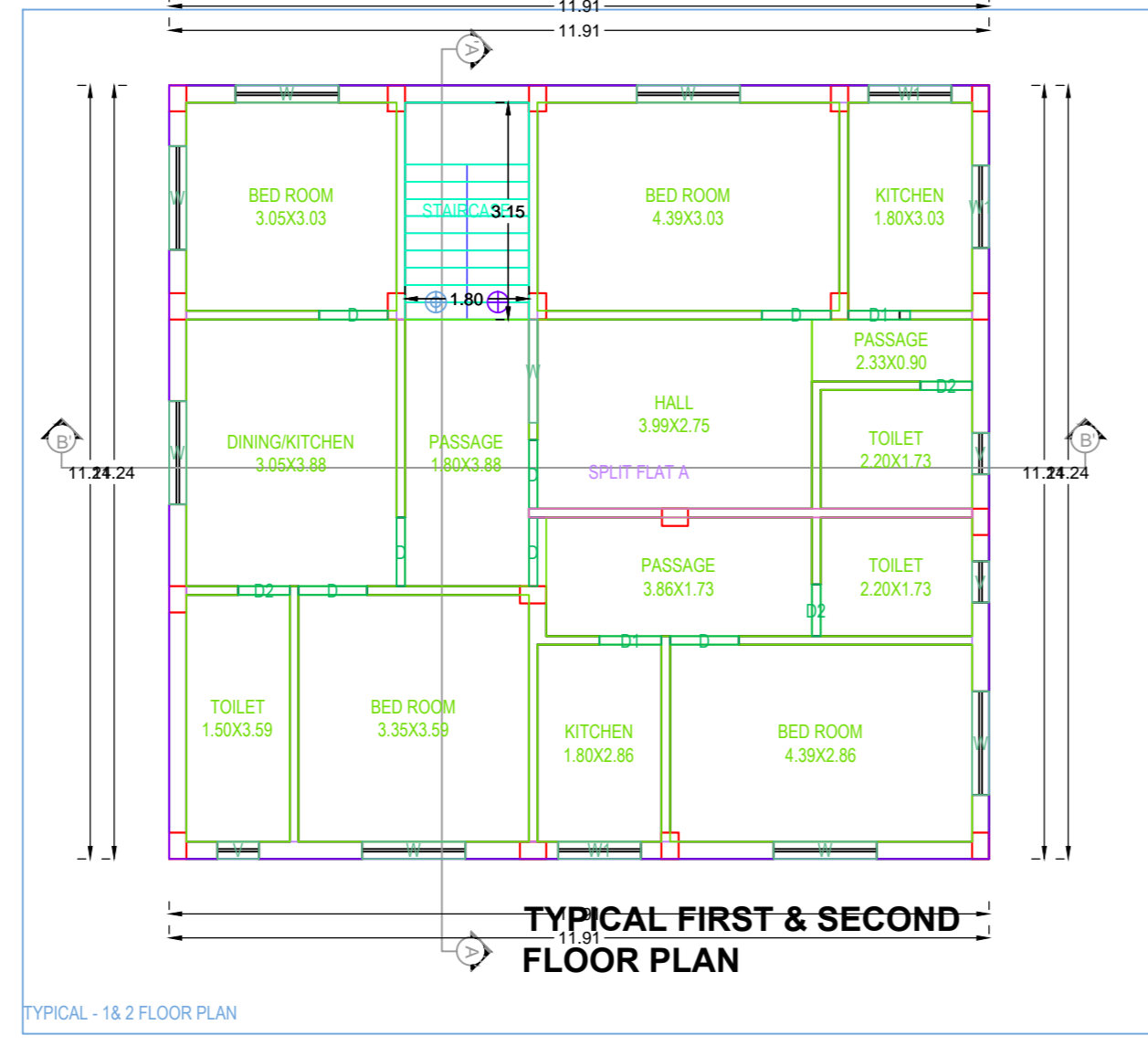
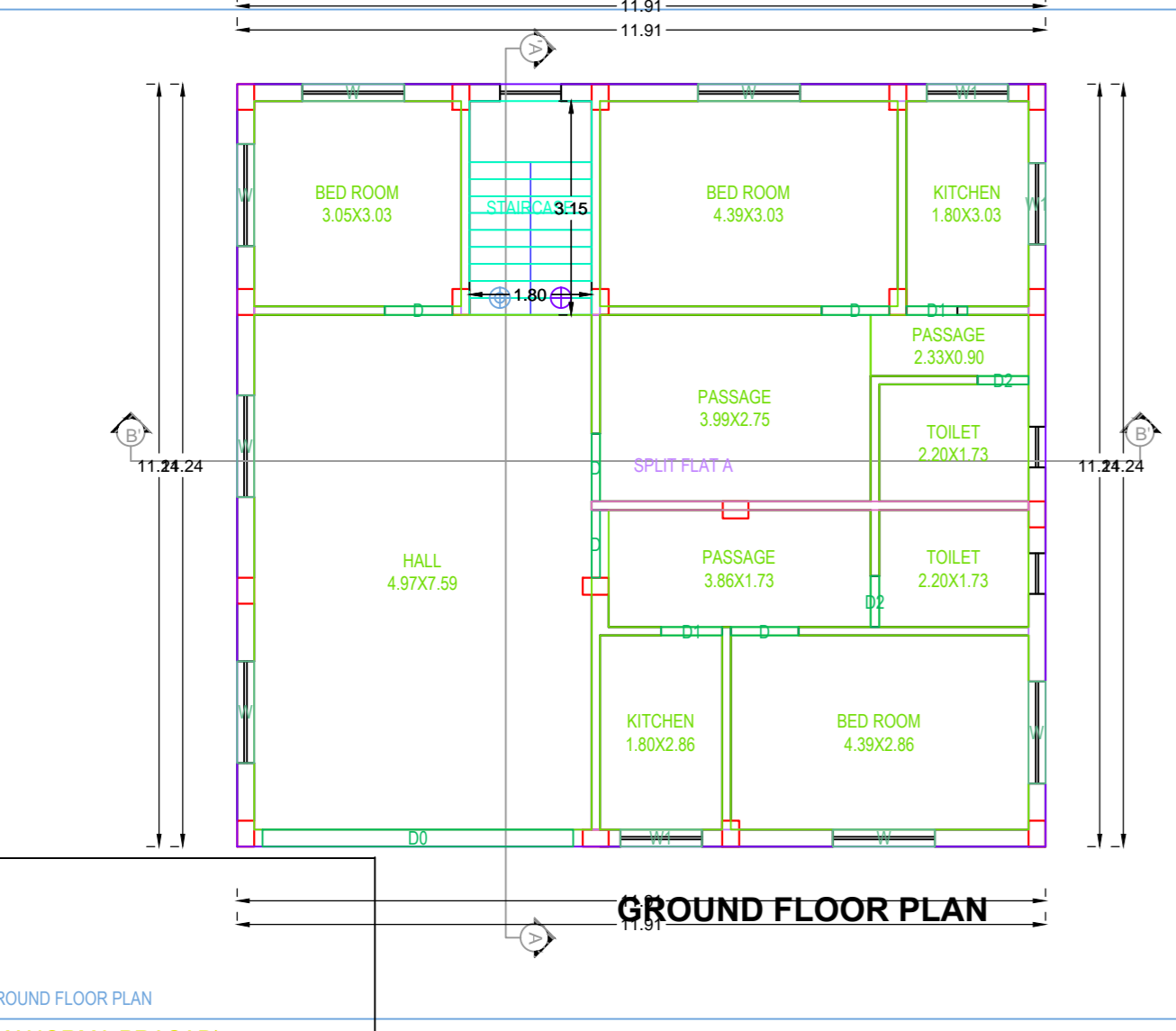
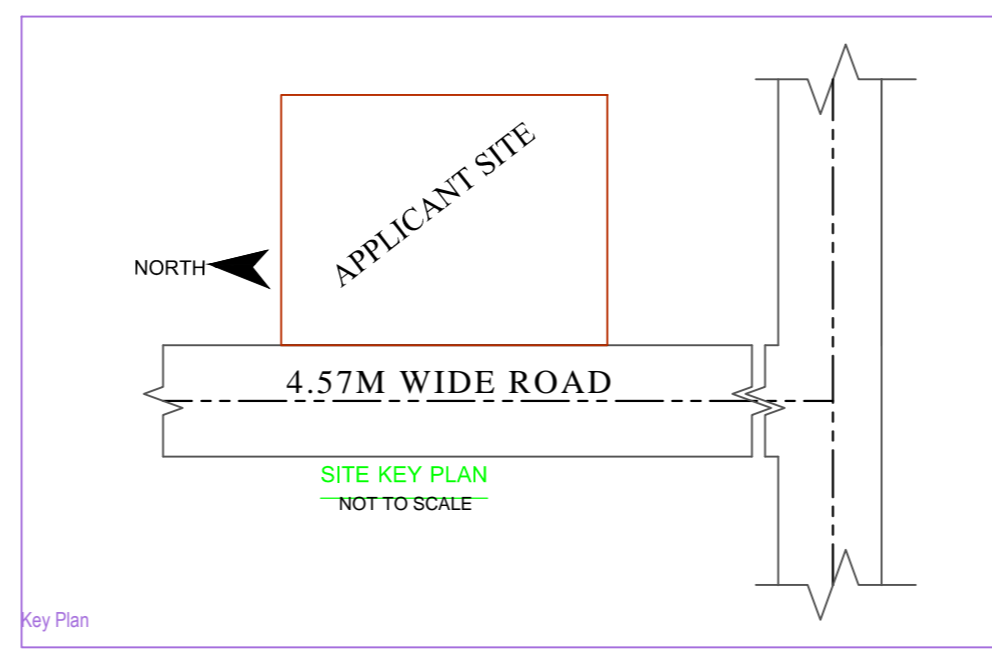
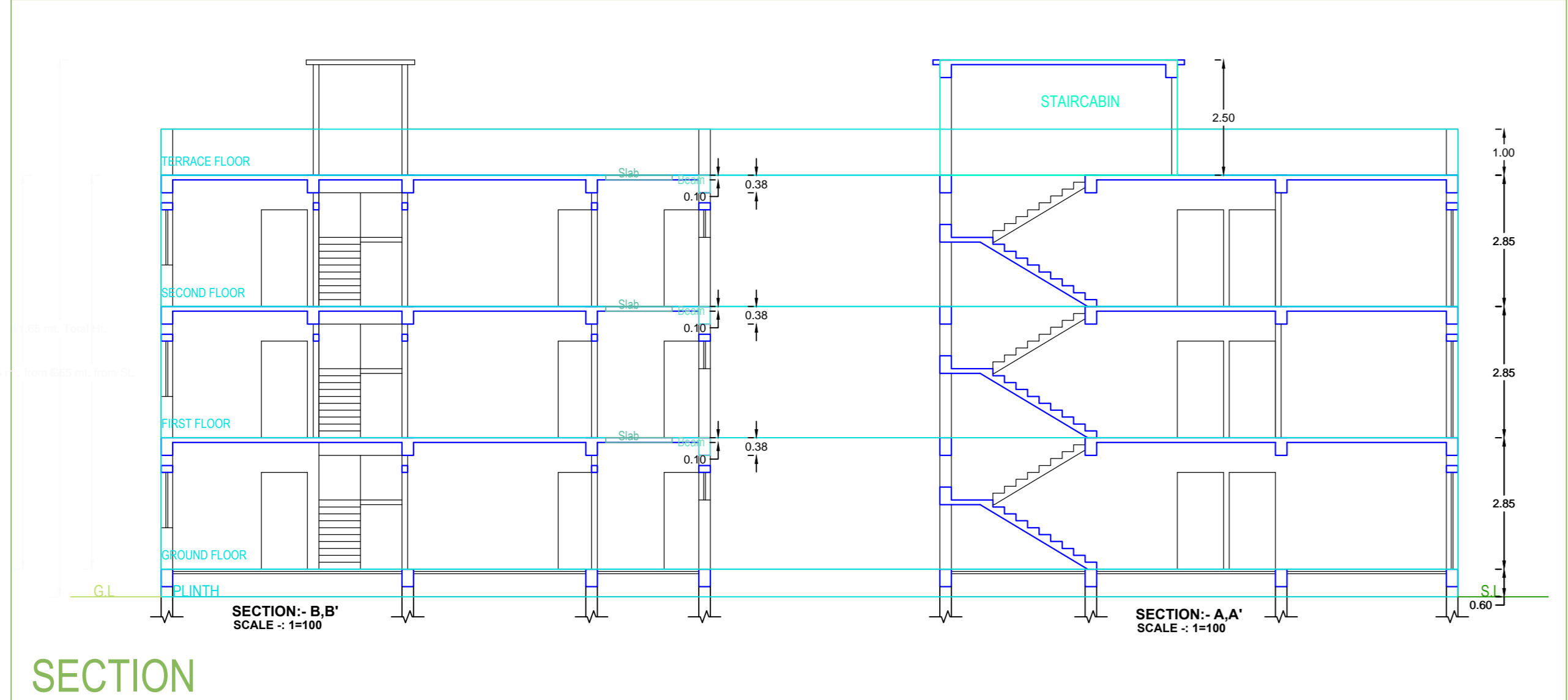
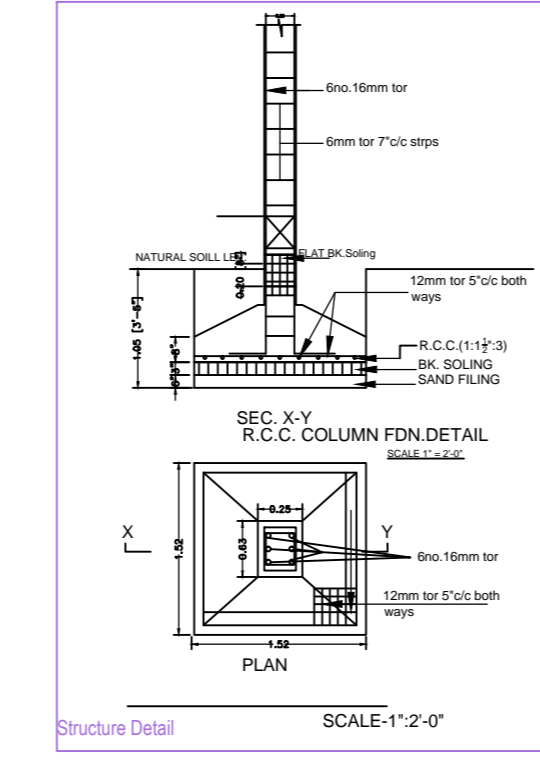
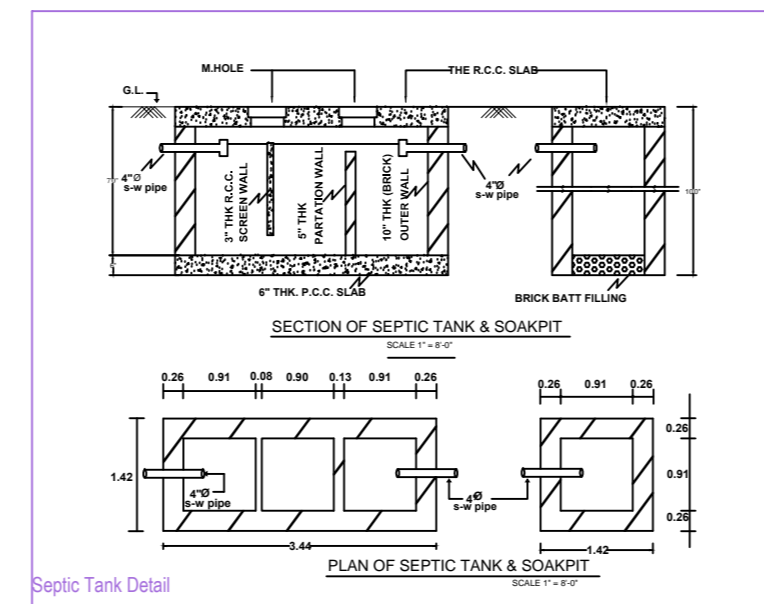
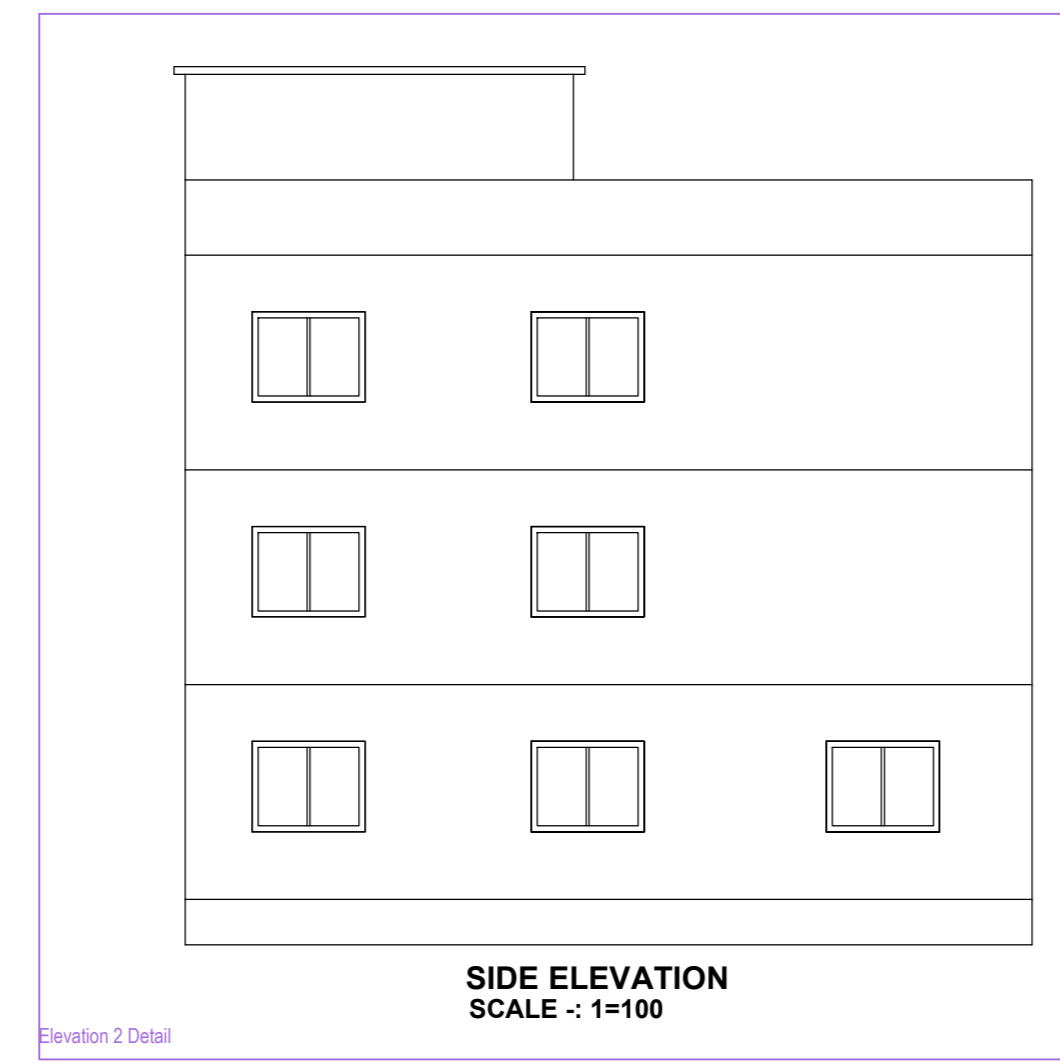
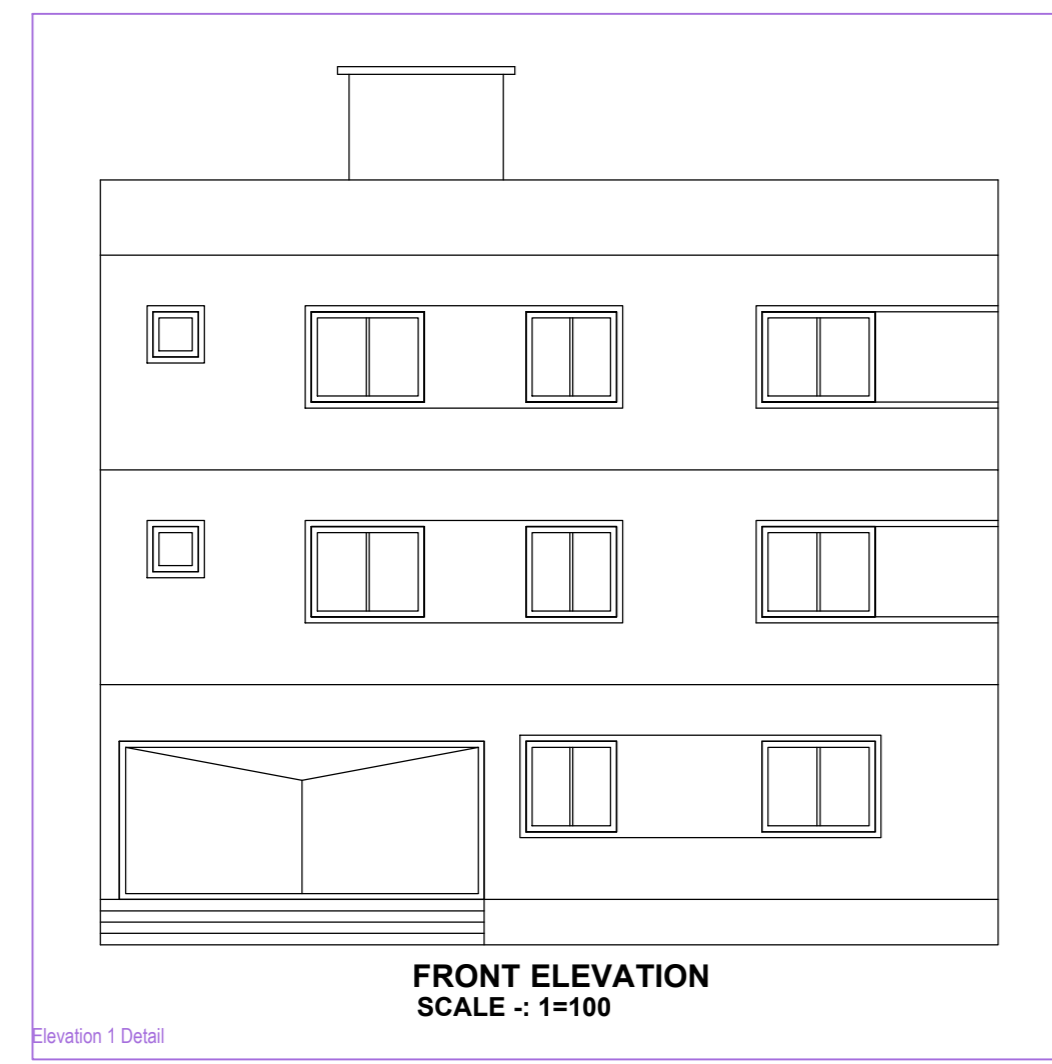

Building -AA (SMT MANORMA PRASAD)

Floor Name	Total Built Up Area (Sq.mt)	Proposed FAR Area (Sq.mt) Resi.	Total FAR Area (Sq.mt)	Tent (No.)
Ground Floor	133.83	133.83	133.83	01
First Floor	133.83	133.83	133.83	00
Second Floor	133.83	133.83	133.83	00
Terrace Floor	0.00	0.00	0.00	00
Total	401.49	401.49	401.49	01
Total Number of Same Buildings	1			
Total	401.49	401.49	401.49	01

SCHEDULE OF JOINERY:

BUILDING NAME	NAME	LENGTH	HEIGHT	NOS
AA (SMT MANORMA PRASAD)	D2	0.75	2.10	08
AA (SMT MANORMA PRASAD)	D1	0.90	2.10	06
AA (SMT MANORMA PRASAD)	D	1.00	2.10	19
AA (SMT MANORMA PRASAD)	D0	4.58	2.10	01
Total	-	-	-	34

SCHEDULE OF JOINERY:

BUILDING NAME	NAME	LENGTH	HEIGHT	NOS
AA (SMT MANORMA PRASAD)	V	0.60	1.00	06
AA (SMT MANORMA PRASAD)	W1	1.20	1.20	09
AA (SMT MANORMA PRASAD)	W	1.50	1.20	23
Total	-	-	-	38

UnitBUA Table for Building -AA (SMT MANORMA PRASAD)

FLOOR	Name	UnitBUA Type	UnitBUA Area	Carpet Area	No. of Rooms	No. of Tenement
GROUND FLOOR PLAN	SPLIT FLAT A	FLAT	232.09	230.48	11	1
Total	-	-	232.09	230.48	99	1

AREA STATEMENT: KODERMA NAGAR PANCHAYAT

PROJECT DETAIL:	VERSION NO: 1.0.37
Inward No.:	Plot Use: Residential
Region: JHARKHAND URBAN LOCAL BODIES	Plot SubUse: Bungalow/ Dwelling / Non Apartment
District: KODERMA	Land Use Zone: RA
Approximation Type: General Proposal	Abutting Road Width: -
Project Type: Building Permission	Plot No.:
Nature of Development: New	Revenue Survey No/Survey No.:
Location: CG Area	Thana No.:
Sub Location: NA	Holding No.:
Village/Mauza Name: -	Khata No.:
Ward No.:	North: -
Road/Street: -	South: -
	East: -
	West: -

AREA DETAILS:

AREA OF PLOT (Minimum)	(A)	SQ.MT.
Net Plot Area (Gross Plot Area - Deductions from Gross Plot Area)	(A-Deductions)	208.90
Deductions for Balance Plot Area (from Gross Plot Area)		
COP Area		12.26
Total		12.26
Balance Plot Area (Net Plot Area - Recreational/Amenity space)	(A-Deductions)	196.63
Plot Area for Coverage (Net Plot Area)	(A-Deductions)	208.90
Plot Area for FSI (Net Plot Area - Road/Watering Area)	(A-Deductions)	208.90
Accessory/Use Area		4.37
COVERAGE CHECK:		
Proposed Coverage Area (64.06 %)		133.83
Total Coverage Area (64.06 %)		133.83
FAR CHECK:		
Proposed Area of FAR		401.49
Total Area of FAR		401.49
BUILT UP AREA CHECK:		
Total Proposed Building Area		401.49
ARCHT/ENGR'S SUPERVISOR (Regd)		OWNER
DEVELOPMENT AUTHORITY		LOCAL BODY

COLOR INDEX

Color	Description
Black	PLOT BOUNDARY
Green	ABUTTING ROAD
Red	PROPOSED WORK (COVERAGE AREA)
Blue	EXISTING (To be retained)
Yellow	EXISTING (To be demolished)

MARGIN DETAIL:

Building / Wing Name	Road Name	Front Margin	Rear Margin	Side Margin	Sidnd Margin
AA1 (SMT MANORMA PRASAD)	4.57M WIDE ROAD	2.50	1.50	0.90	0.90

FAR & Tenement Details (Table 4c-1)

Building	No. of Same Bldg	Total Built Up Area (Sq.mt)	Proposed FAR Area (Sq.mt) Resi.	Total FAR Area (Sq.mt)	Tent (No.)
AA (SMT MANORMA PRASAD)	1	401.49	401.49	401.49	01
Grand Total:	1	401.49	401.49	401.49	01