

Proposal Basic Information	
Proposal File No.	KONPCBP0044W052024
Owner Name	SMT MANORMA PRASAD
Khata No.	602
Plot No.	689
Village Name	Kodma
Use	Residential
SubUse	Bungalow Dwelling / Non Apartment

AREA STATEMENT		VERSION NO. 1.0.73
KODERMA NAGAR PANCHAYAT		VERSION DATE: 16/10/2020
PROJECT DETAIL:		
Region: JHARKHAND URBAN	Plot Use: Residential	
Local Bodies: KODERMA	Plot SubUse: Bungalow Dwelling / Non Apartment	
District: KODERMA	Plot/Use/Religious/Structure: NA	
Authority: KODERMA NAGAR PANCHAYAT	Plot/Use/Religious/Structure: NA	
Invent. No: KONPCBP0044W052024	Plot/Use/Religious/Structure: NA	
Application Type: General Proposal	North Plot No. - N2 VENDER	
Project Type: Building Permission	South Plot No. - MURLU DAS	
Name of Development: New	East Plot No. - NARESH CHANDRA	
Location of Development Area: Old Area	West: Road Width - 4.57M WIDE ROAD	
AREA DETAILS:		
AREA OF PLOT (Minimum)	(A)	208.90
NET AREA OF PLOT (Gross Plot Area - Deduction from Gross Plot area)	(A-Deductions)	208.90
Deduction for Balance Plot Area/From Gross Plot Area		
Common Plot		12.26
Total		12.26
BALANCE AREA OF PLOT (Net Plot Area - Recreational/Openly space)	(A-Deductions)	196.63
Plot Area for FAR (Net Plot Area + Road/Widening Area)	(A-Deductions)	208.90
Plot Area for FAR (Net Plot Area + Road/Widening Area)	(A-Deductions)	208.90
COVERAGE CHECK		
Permissible Coverage area (70.00 %)		146.23
Proposed Coverage Area (64.07 %)		133.83
Total Prop. Coverage Area (64.07 %)		133.83
Balance coverage area (5.94 %)		12.40
FAR CHECK		
Perm. FAR Area (1.500)		313.35
Total Perm. FAR area		313.35
Proposed FAR Area		308.15
Total Proposed FAR Area		308.15
Consumed FAR (Factor)		1.48
Balance FAR Area		5.20
BUILT UP AREA CHECK		
Total Proposed Built-up Area		401.49
ARCHITECT (Regd.)		
ENGINEER (Regd.) MD SHOAB ALAM		
SUPERVISOR (Regd.)		
OWNER (Regd.) SMT MANORMA PRASAD		
DEVELOPMENT AUTHORITY		
LOCAL BODY		

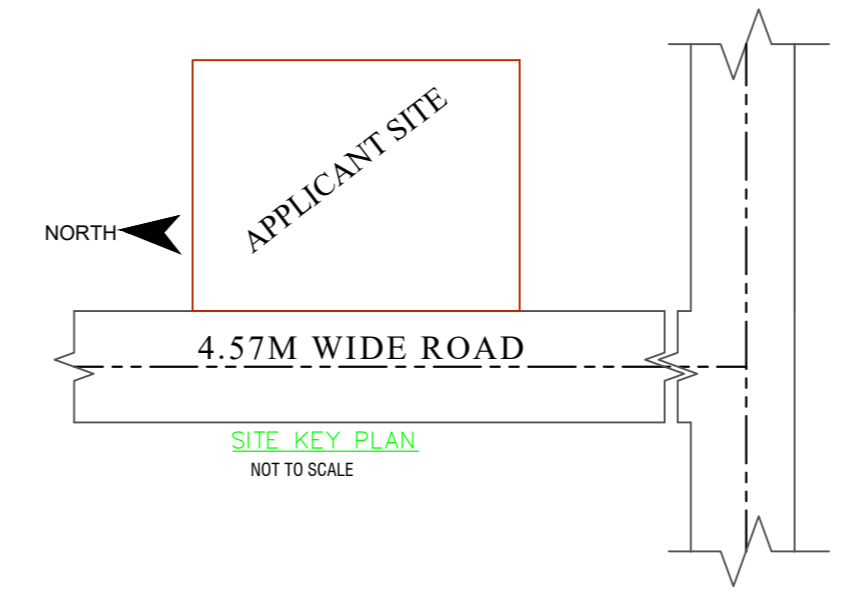
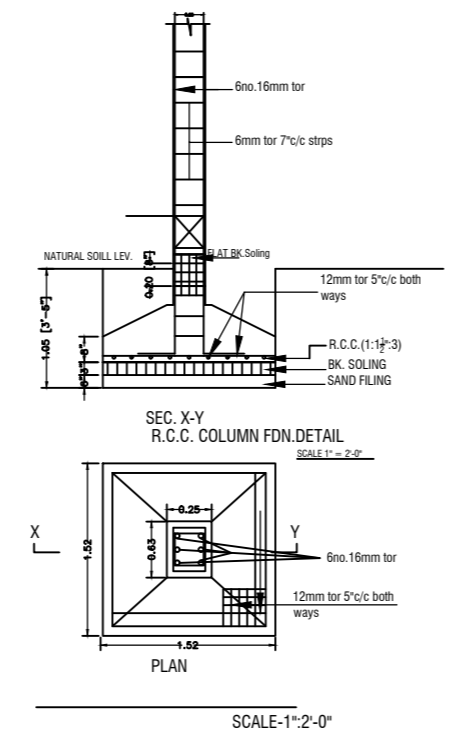
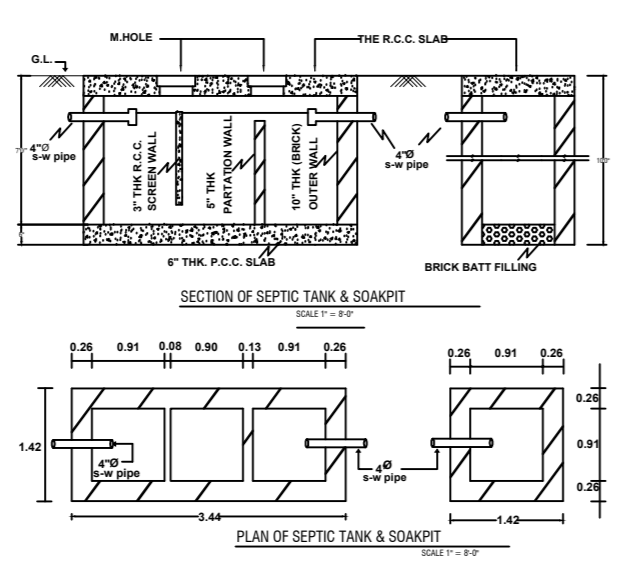
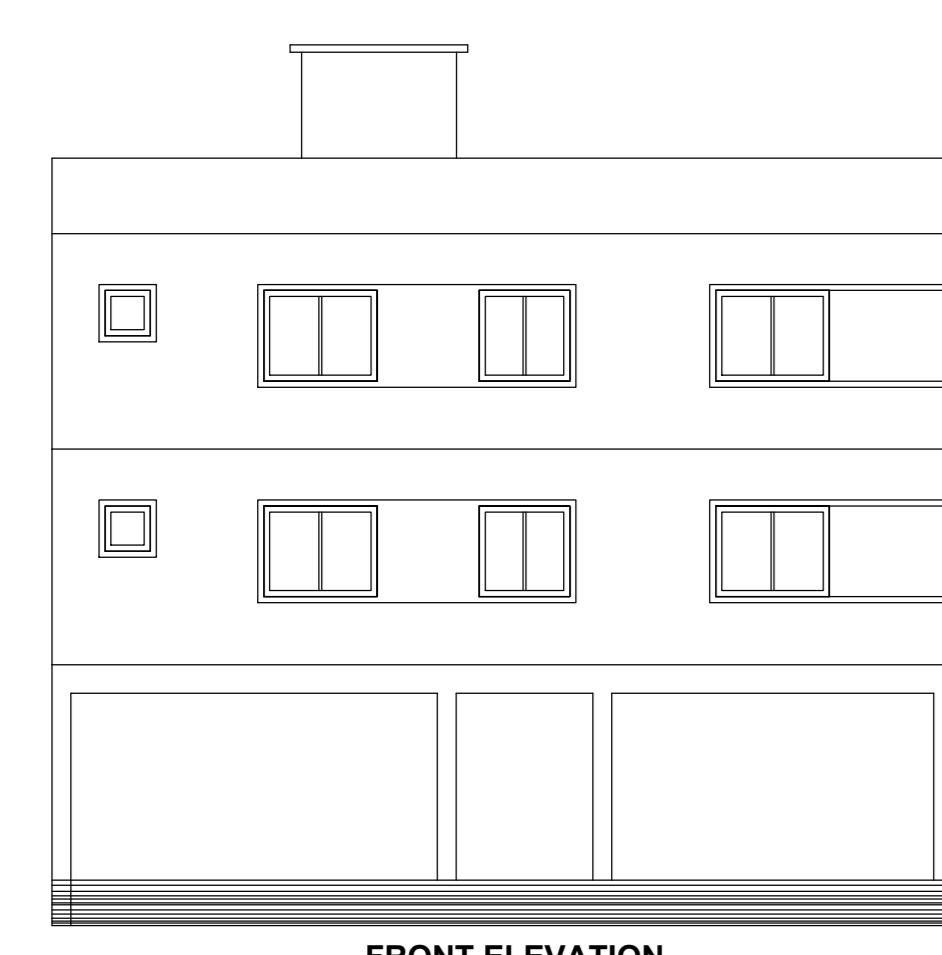
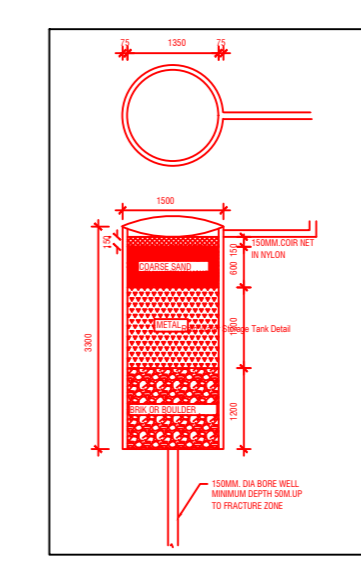
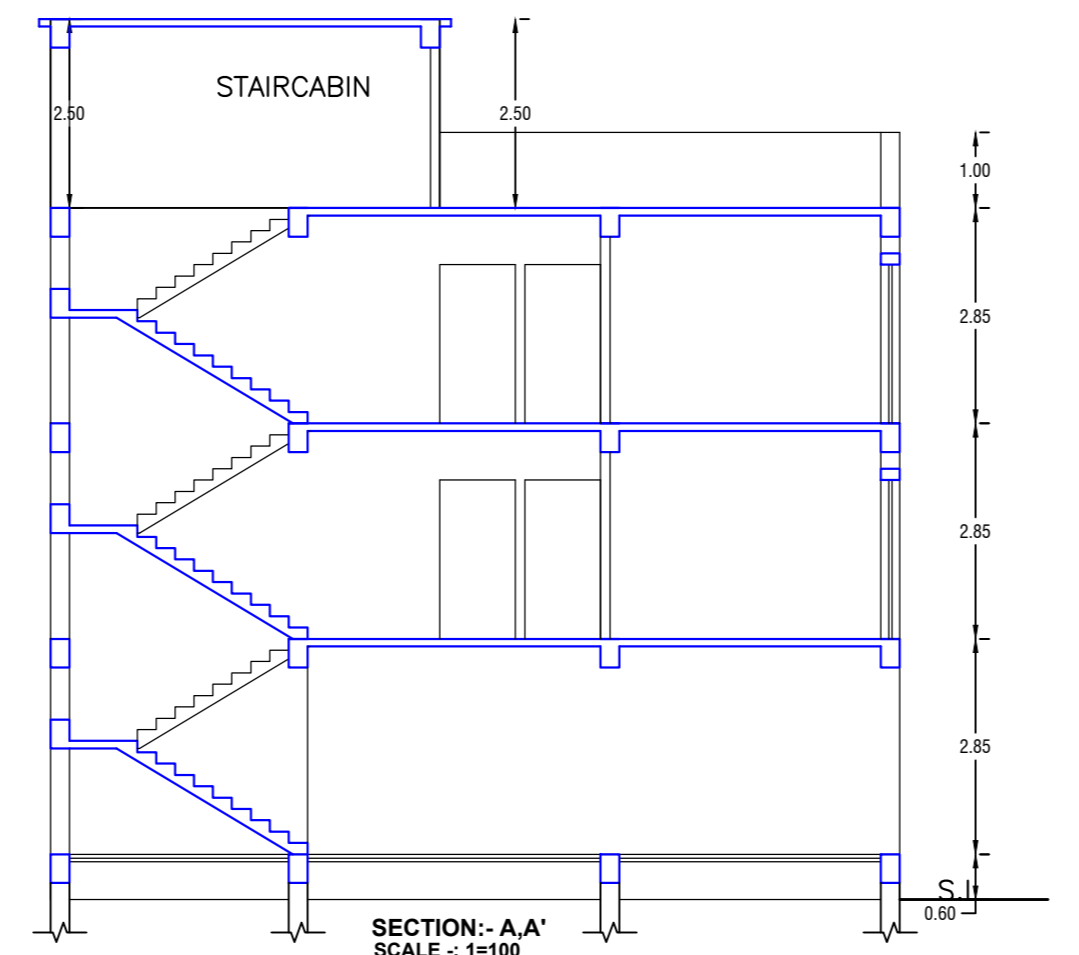
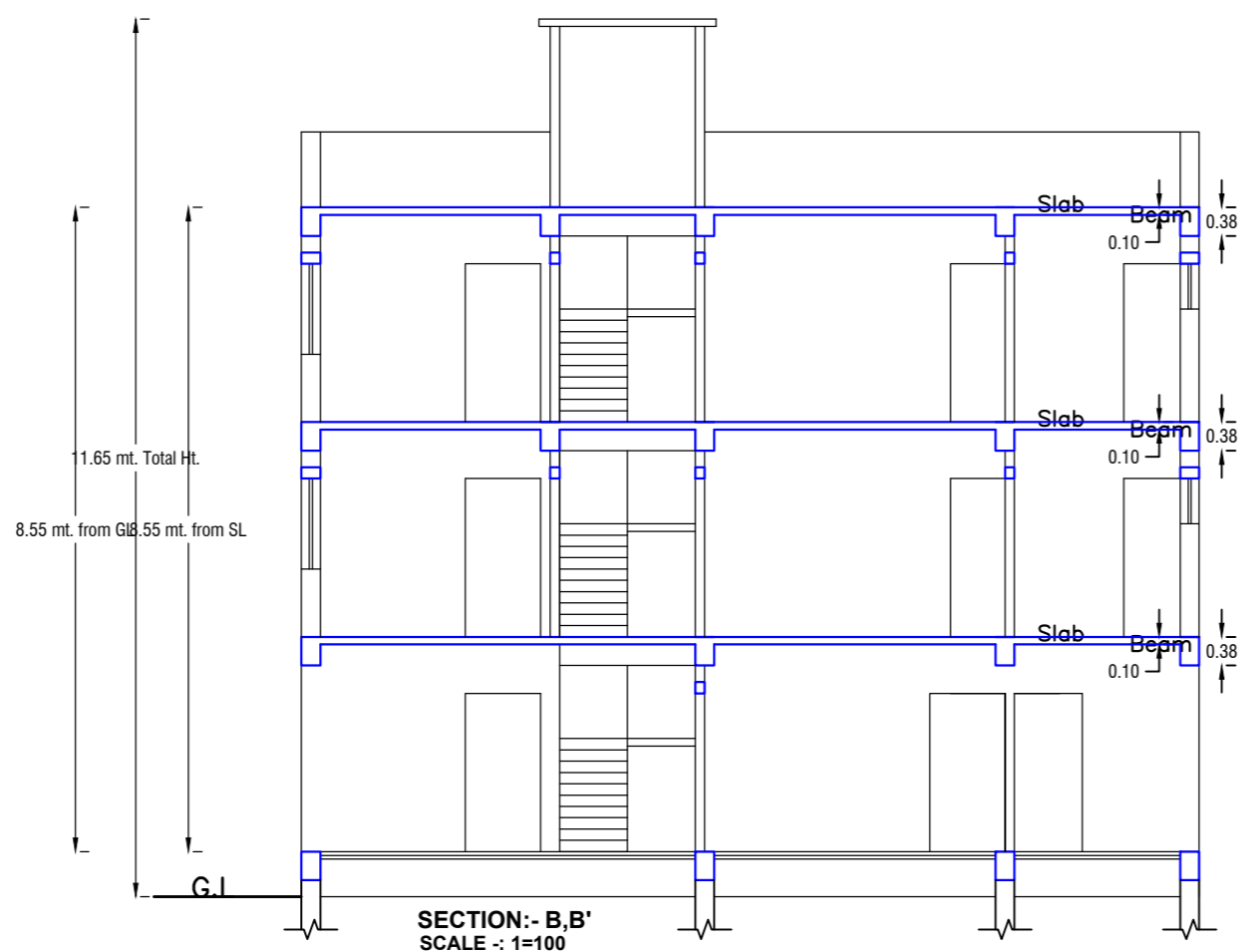
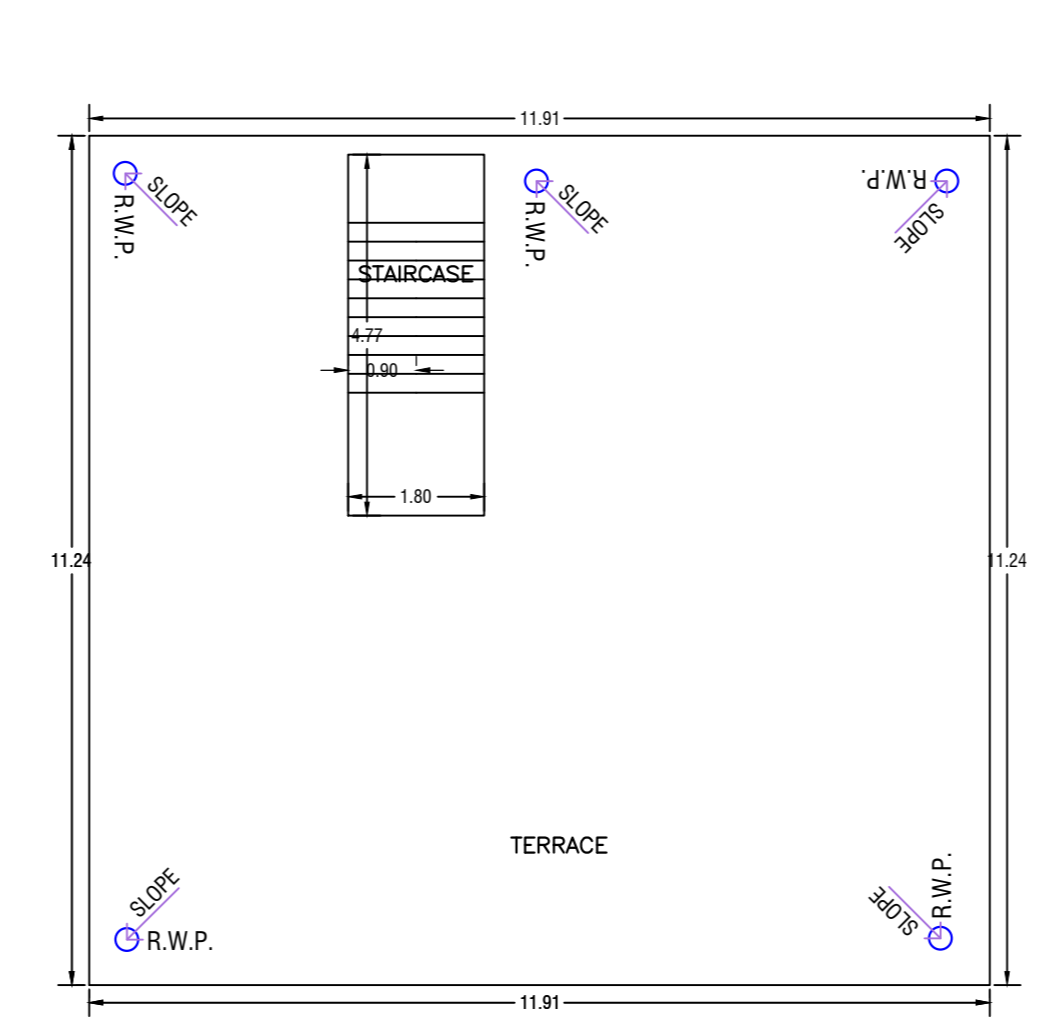
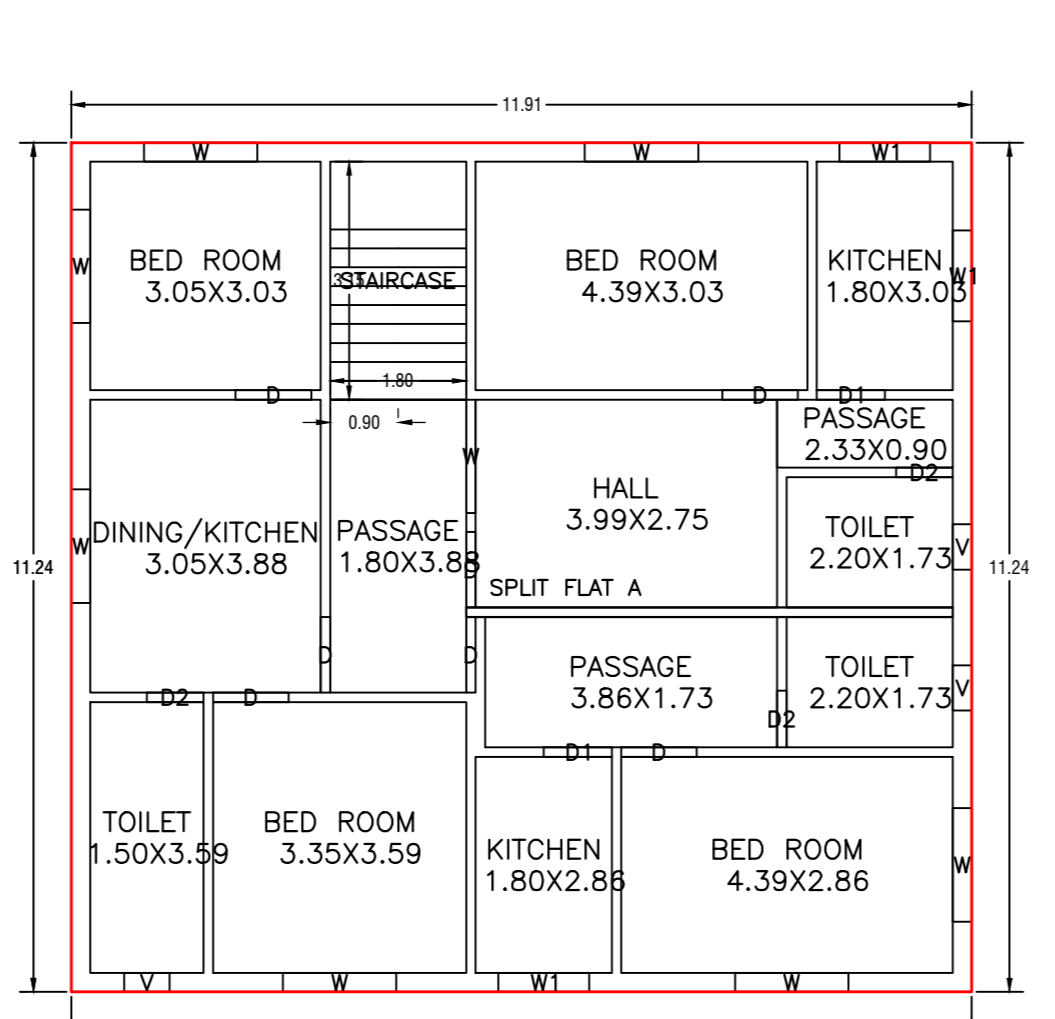
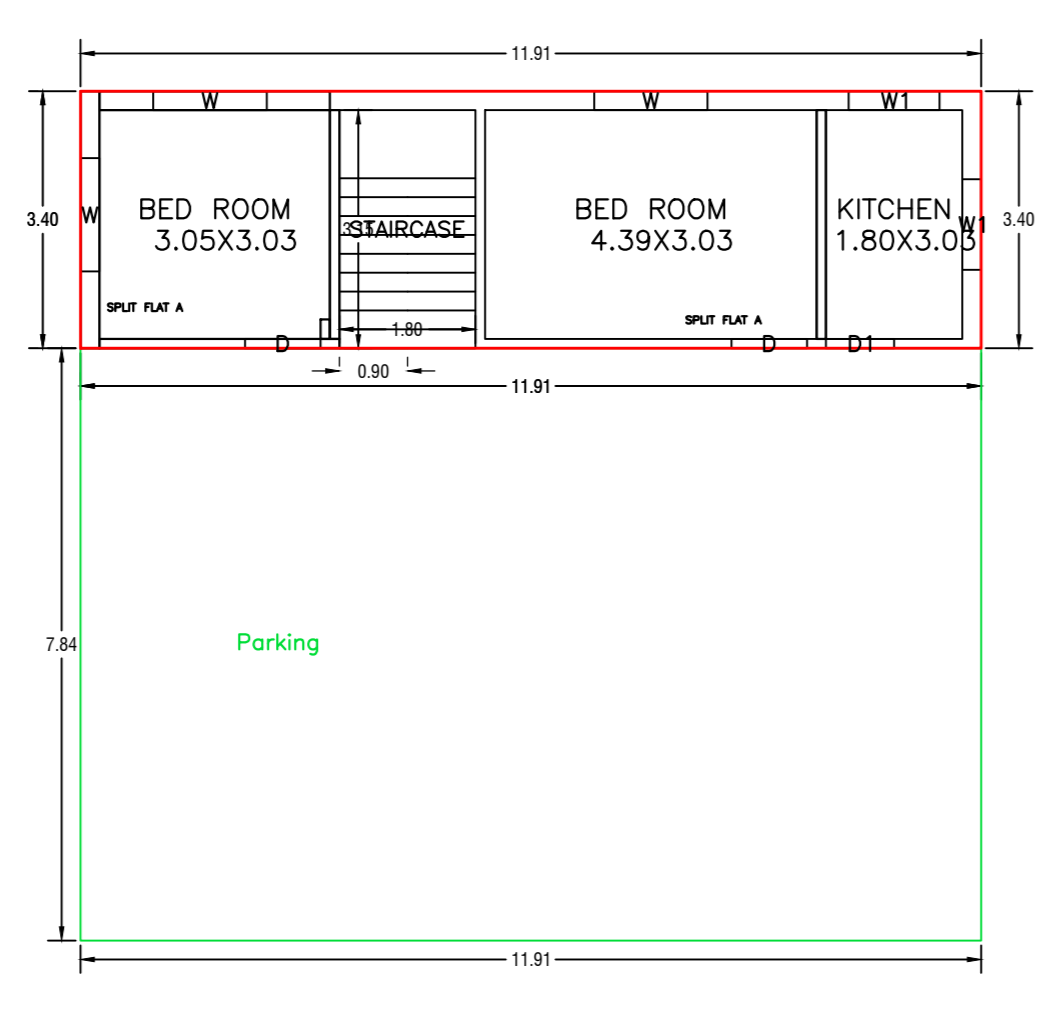
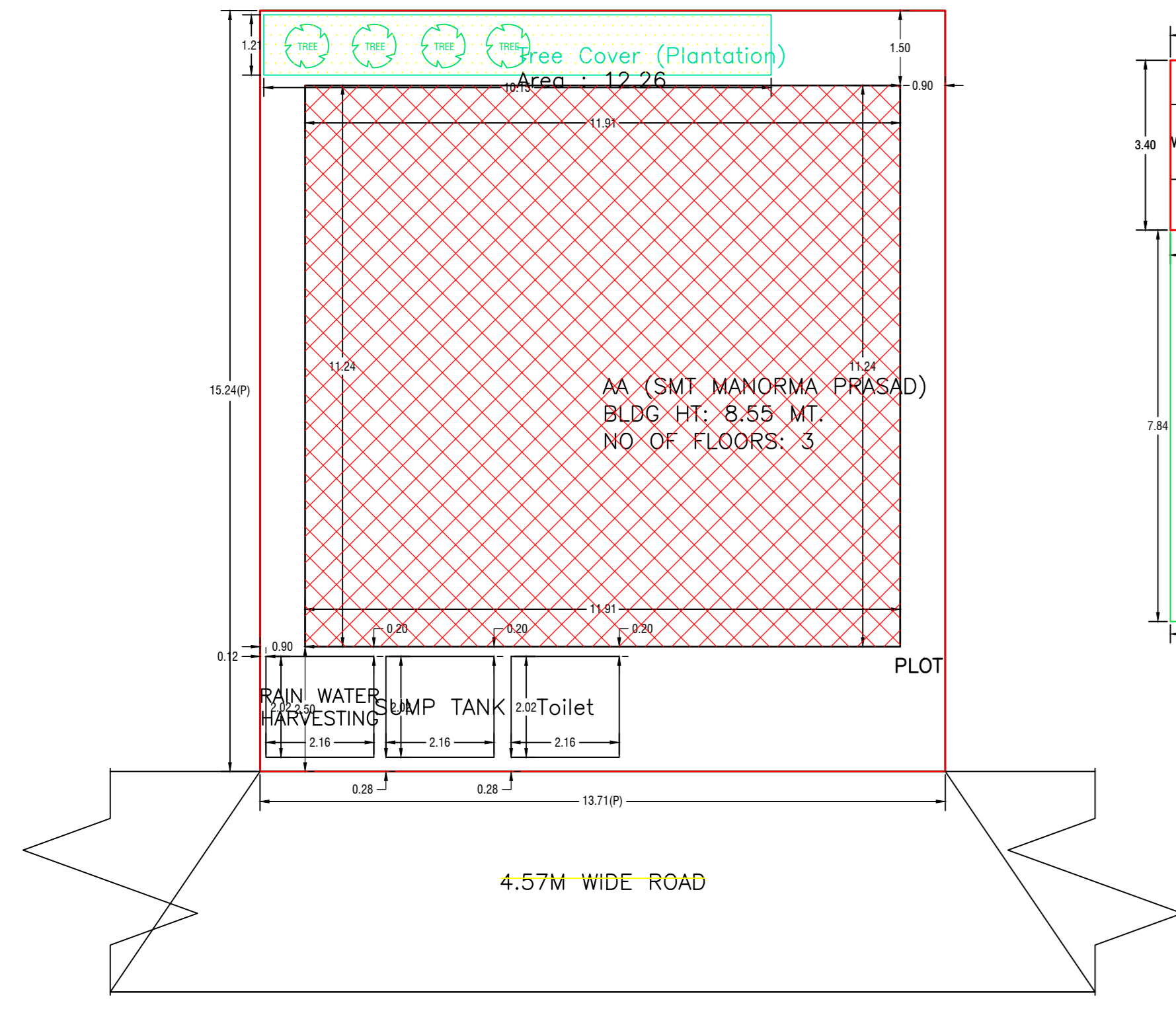

Building :AA (SMT MANORMA PRASAD)

Floor Name	Total Built Up Area (Sq.mt)	Deductions (Area in Sq.mt)	Proposed FAR Area (Sq.mt)	Total FAR Area (Sq.mt)	Total Consumed Additional FAR Area (Sq.mt)	Trmt (No.)
Ground Floor	133.83	93.33	40.50	40.50	40.50	01
First Floor	133.83	0.00	133.83	133.83	133.83	00
Second Floor	133.83	0.00	133.83	133.83	133.83	00
Terrace Floor	0.00	0.00	0.00	0.00	0.00	00
Total	401.49	93.33	308.16	308.16	308.16	01
Total Number of Same Buildings	1					
Total:	401.49	93.33	308.16	308.16	308.16	01

SCHEDULE OF DOOR:

BUILDING NAME	NAME	LENGTH	HEIGHT	NOS
AA (SMT MANORMA PRASAD)	D2	0.75	2.10	06
AA (SMT MANORMA PRASAD)	D1	0.90	2.10	05
AA (SMT MANORMA PRASAD)	D	1.00	2.10	16

SCHEDULE OF WINDOW/VENTILATION:

BUILDING NAME	NAME	LENGTH	HEIGHT	NOS
AA (SMT MANORMA PRASAD)	V	0.60	0.60	06
AA (SMT MANORMA PRASAD)	W1	1.20	1.20	08
AA (SMT MANORMA PRASAD)	W	1.50	1.20	19

UnitBUA Table for Building :AA (SMT MANORMA PRASAD)

FLOOR	Name	UnitBUA Type	UnitBUA Area	Carpet Area	No. of Rooms	No. of Tenement
GROUND	SPLIT FLAT A	FLAT	260.41	258.39	1	1
FLOOR PLAN	SPLIT FLAT A	FLAT	0.00	0.00	2	1
TYPICAL - 1 & 2 FLOOR PLAN	SPLIT FLAT A	FLAT	0.00	0.00	14	0
Total	-	-	260.41	258.39	31	1

FAR & Tenement Details (Table 4c-1)

Building	No. of Same Bldg	Total Built Up Area (Sq.mt)	Deductions (Area in Sq.mt)	Proposed FAR Area (Sq.mt)	Total FAR Area (Sq.mt)	Total Consumed Additional FAR Area (Sq.mt)	Trmt (No.)
AA (SMT MANORMA PRASAD)	1	401.49	93.33	308.16	308.16	308.16	01
Grand Total:	1	401.49	93.33	308.16	308.16	308.16	01

Building USE/SUBUSE Details

Building Name	Building Use	Building SubUse	Building Structure	Floor Name	Floor Use	Floor SubUse	FAR Name	FAR Use	FAR SubUse
AA (SMT MANORMA PRASAD)	Residential	Bungalow Dwelling / Non Apartment	Non Highrise	GROUND FLOOR PLAN	Residential	Bungalow Dwelling / Non Apartment	Residential FAR	Residential	Bungalow Dwelling / Non Apartment
				TYPICAL - 1 & 2 FLOOR PLAN	Residential	Bungalow Dwelling / Non Apartment	Residential FAR	Residential	Bungalow Dwelling / Non Apartment
				TERRACE FLOOR PLAN	Residential	Bungalow Dwelling / Non Apartment	-	-	-

Buildingwise Floor FAR Details

Floor Name	Proposed Built Up Area (Sq.mt)	Proposed FAR Area (Sq.mt)	Total Proposed Built Up Area (Sq.mt)	Total FAR Area (Sq.mt)
Ground Floor	133.83	40.50	133.83	40.50
First Floor	133.83	133.83	133.83	133.83
Second Floor	133.83	133.83	133.83	133.83
Terrace Floor	0.00	0.00	0.00	0.00
Total:	401.49	308.16	401.49	308.16

COLOR INDEX

█	█	█	█	█	█
█	█	█	█	█	█
█	█	█	█	█	█
█	█	█	█	█	█
█	█	█	█	█	█
█	█	█	█	█	█
█	█	█	█	█	█

EXISTING (To be retained)
EXISTING (To be demolished)

LTP NAME AND SIGNATURE	STRUCTURAL ENG'S NAME AND SIGNATURE	BUILDER NAME AND SIGNATURE	DIGITAL SIGNATURE
MD SHOAB ALAM KONPC/ENG/0004/2017			