

TERRACE FLOOR PLAN (SCALE 1:100)

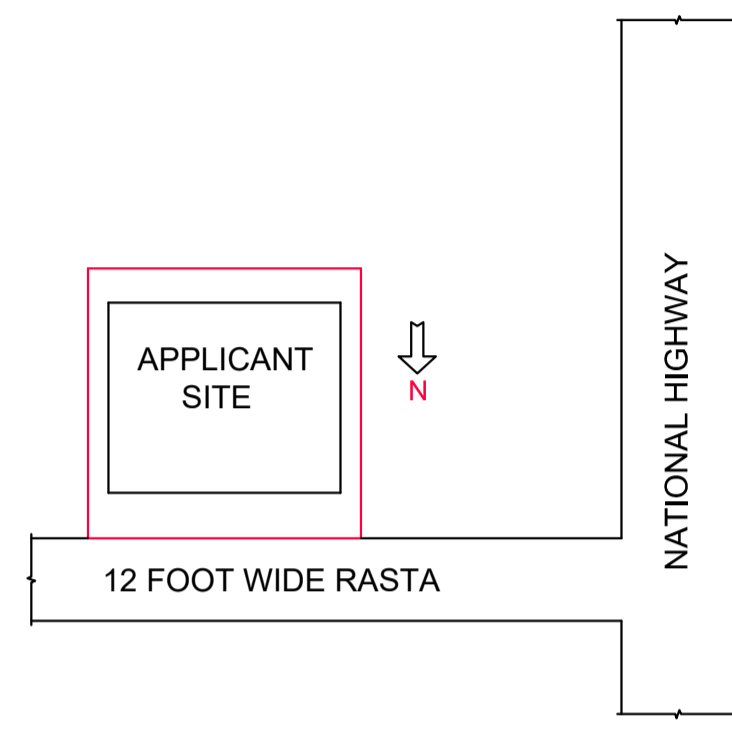

LOCATION PLAN NOT TO SCALE

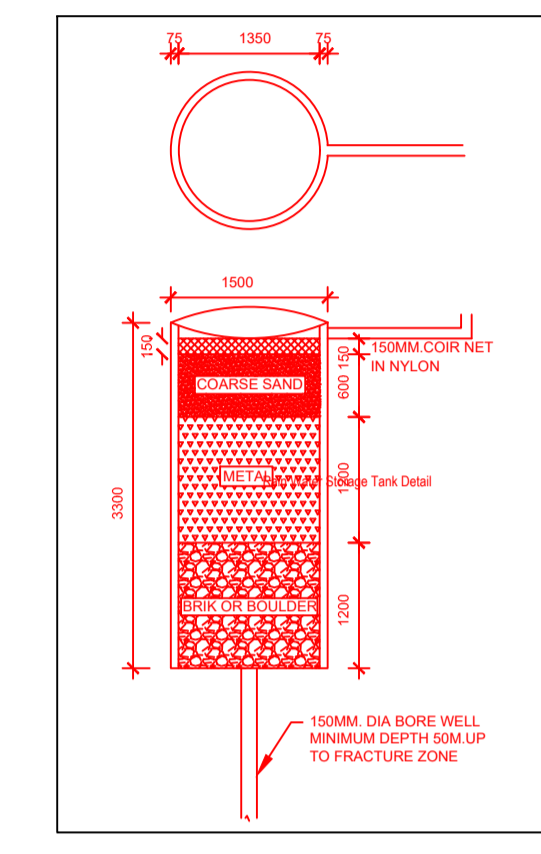

FAR & Tenement Details (Table 4c-1)

Building	No. of Same Bldg	Total Built Up Area (Sq.mt.)	Proposed FAR Area (Sq.mt.) Resi.	Total FAR Area (Sq.mt.)	Total Consumed Additional FAR Area (Sq.mt.)	Tnmt (No.)
AAA (PRADEEP KUMAR)	1	171.78	171.78	171.78	171.78	01
Grand Total :	1	171.78	171.78	171.78	171.78	01

Proposal Basic Information

Proposal File No.	KONPC/SUP/0002/W08/2024
Owner Name	PRADEEP KUMAR
Khata No	11
Plot No	3439
Village Name	Koderma
Use	Residential
SubUse	Bungalow/ Dwelling / Non Apartment

AREA STATEMENT

AREA DETAILS	SQ.MT.
AREA OF PLOT (Minimum)	143.13
NET AREA OF PLOT (Gross Plot Area - Deduction from Gross Plot area)	143.13
Deduction for Balance Plot Area (from Gross Plot Area)	
Common Plot	20.57
Total	20.57
BALANCE AREA OF PLOT (Net Plot Area - Recreational/Amenity space)	122.56
PLOT AREA FOR COVERAGE (Net Plot Area)	143.13
Plot Area for FAR (Net Plot Area + Road Widening Area)	143.13

COVERAGE CHECK

Permissible Coverage area ( 70.00 % )	100.19
Proposed Coverage Area ( 60.01 % )	85.89
Total Prop. Coverage Area ( 60.01 % )	85.89
Balance coverage area ( 9.99 % )	14.30

FAR CHECK

Perm. FAR Area ( 1.500 )	214.70
Total Perm. FAR area	214.70
Residential FAR	171.79
Proposed FAR Area	171.79
Total Proposed FAR Area	171.79
Consumed FAR (Factor)	1.20
Balance FAR Area	42.91

BUILT UP AREA CHECK

Total Proposed BuiltUp Area	171.78
-----------------------------	--------

ARCHITECT (Regd) Amrendra Kumar  
ENGINEER (Regd)  
SUPERVISOR (Regd)  
OWNER (Regd) PRADEEP KUMAR

DEVELOPMENT AUTHORITY LOCAL BODY

SITE PLAN

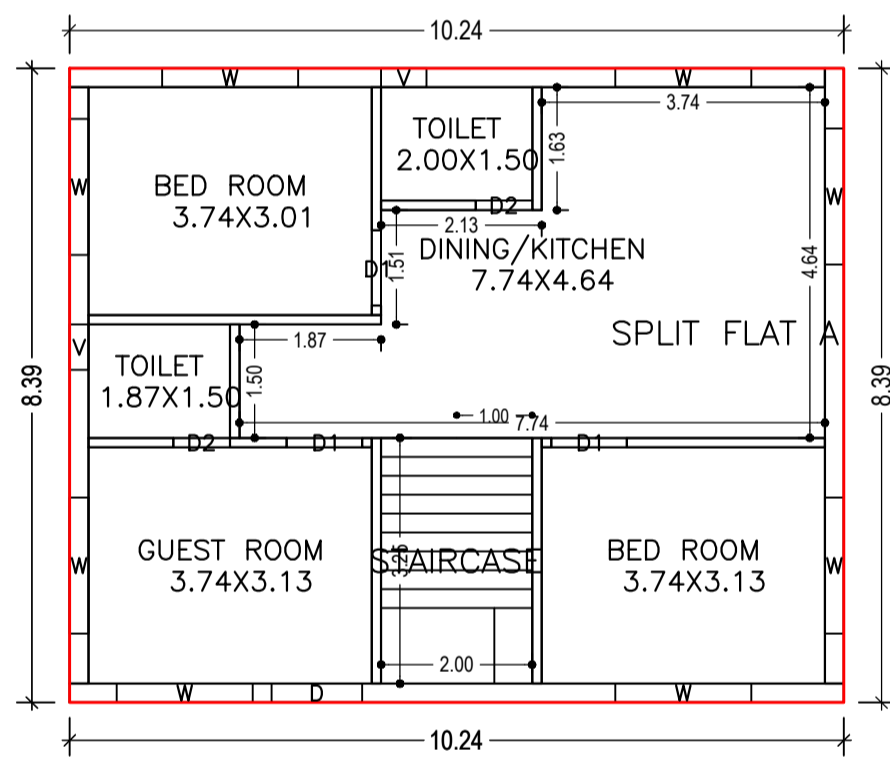

GROUND FLOOR PLAN (Proposed) (SCALE 1:100)

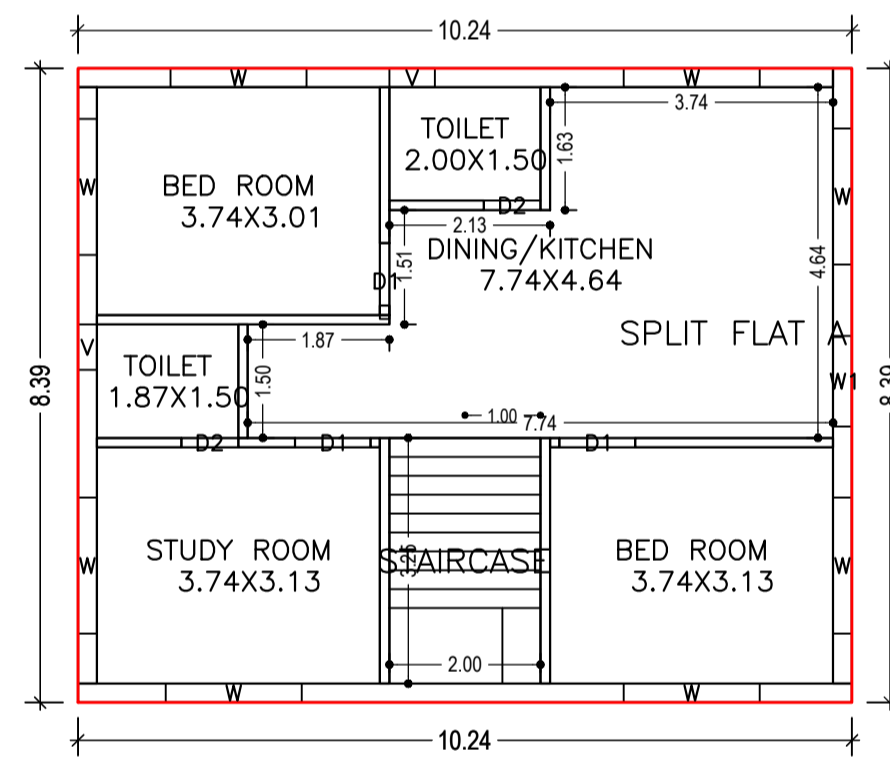

FIRST FLOOR PLAN (Proposed) (SCALE 1:100)

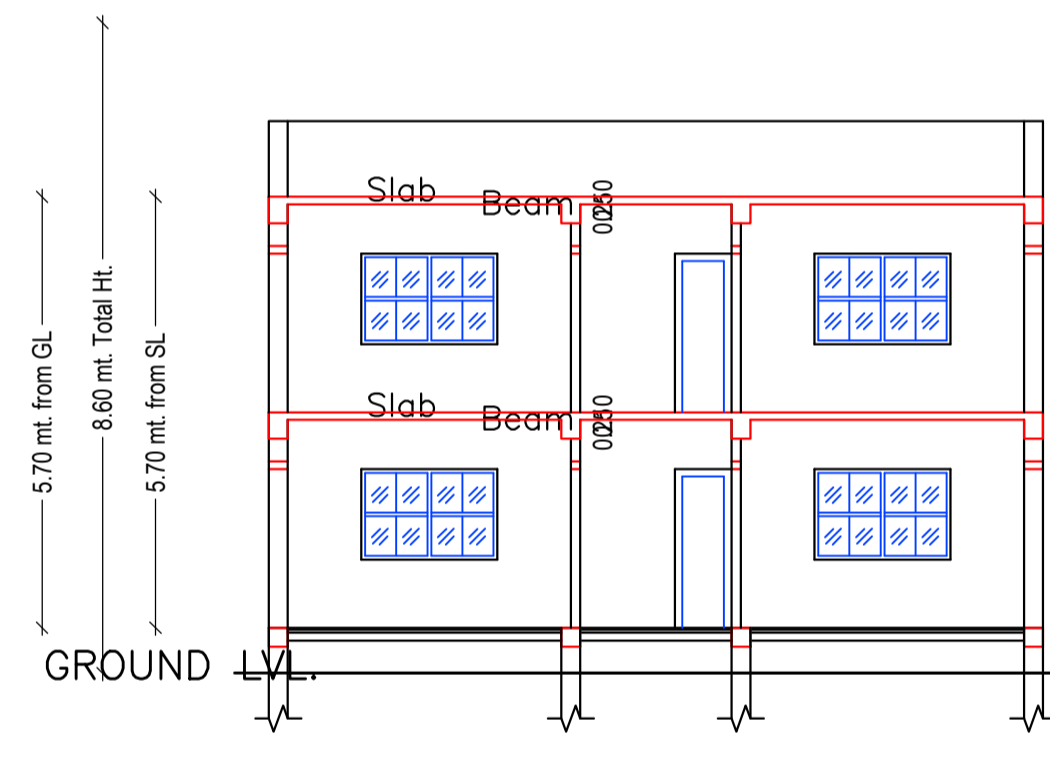

SECTION X-X

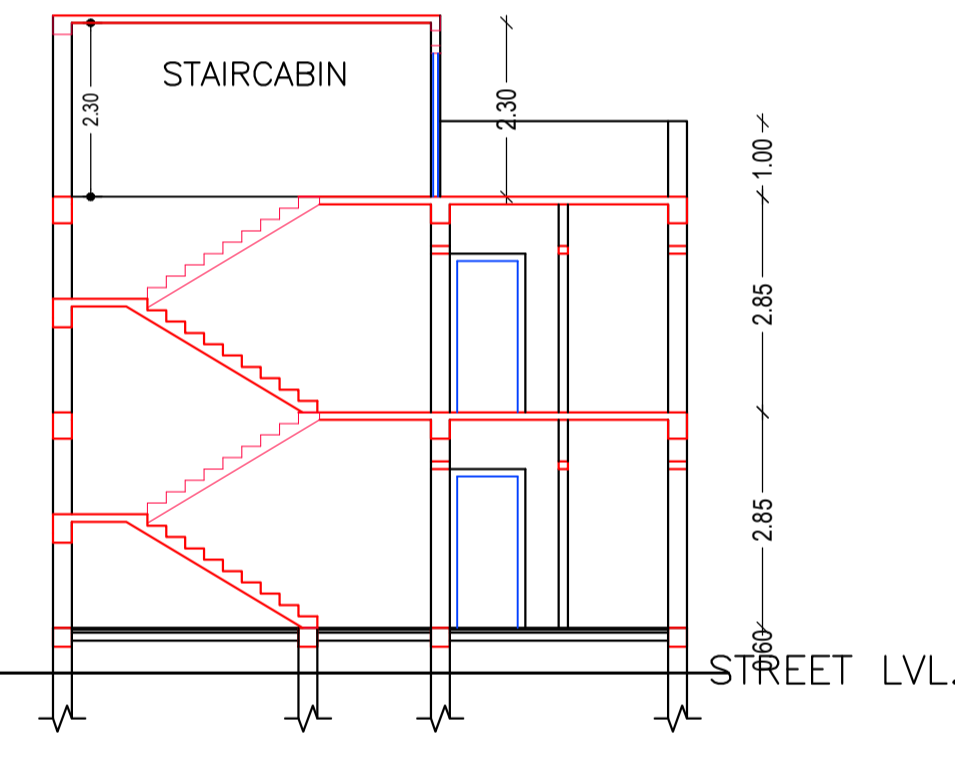

SECTION Y-Y

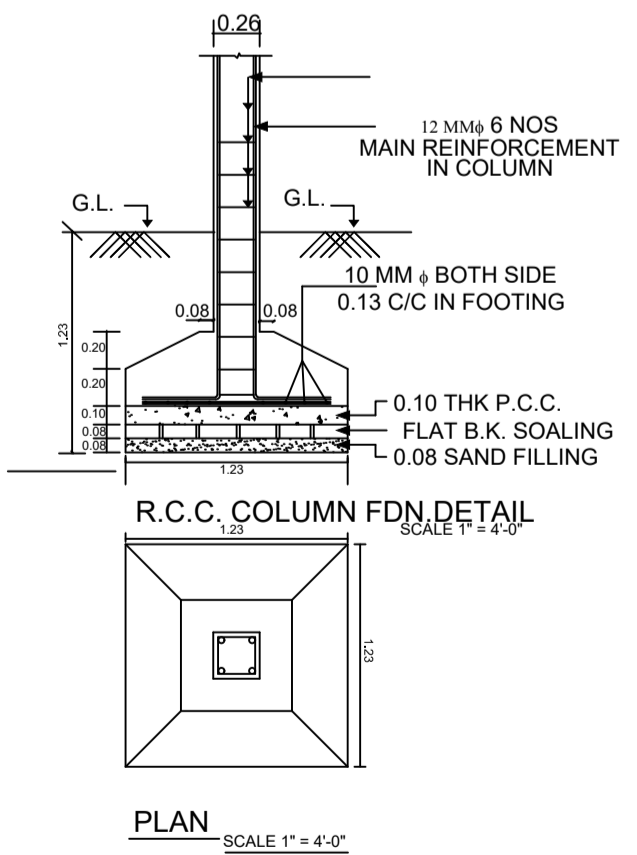

R.C.C. COLUMN FDN DETAIL (SCALE 1" = 4'-0")

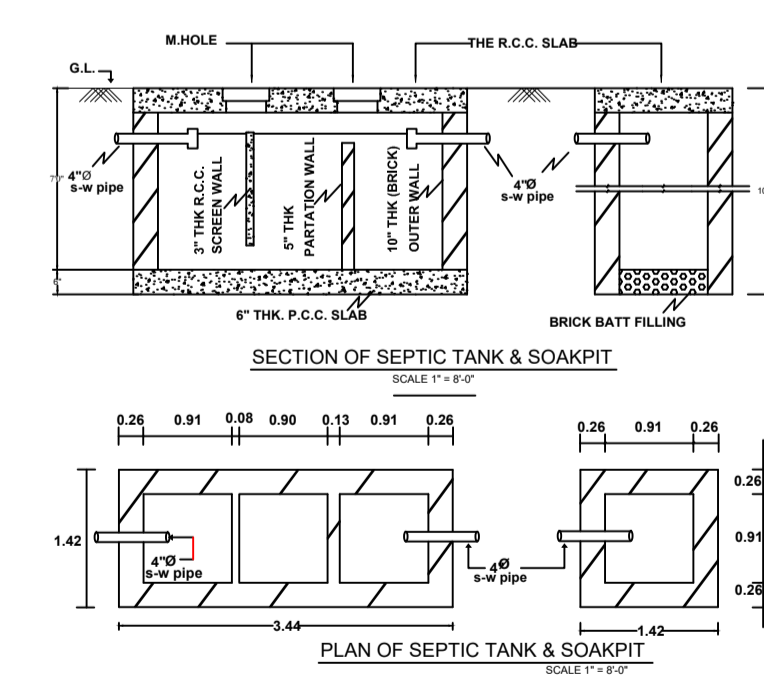

SECTION OF SEPTIC TANK & SOAKPIT (SCALE 1" = 4'-0")

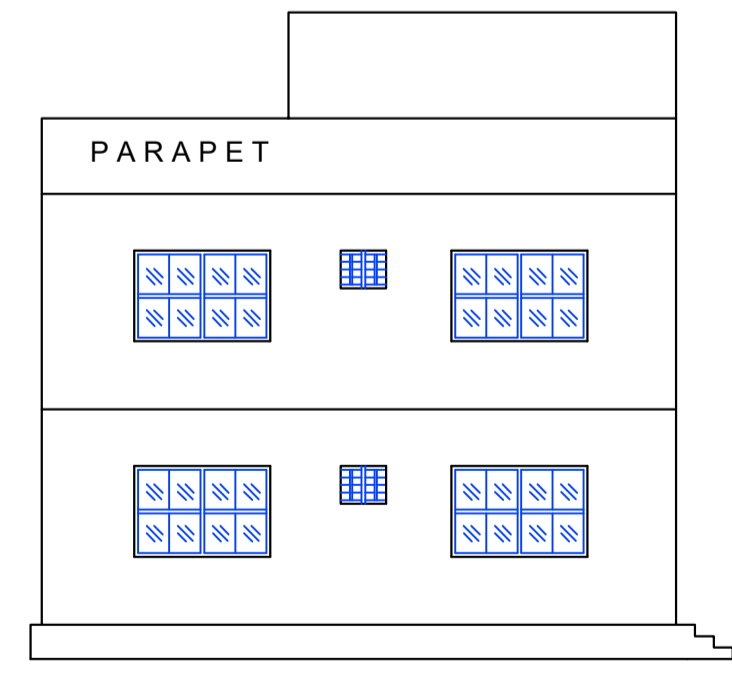

SIDE ELEVATION

COLOR INDEX

PLOT BOUNDARY	Black
ABUTTING ROAD	Green
PROPOSED CONSTRUCTION	Red
COMMON PLOT	Yellow
ROAD WIDENING AREA	Blue
EXISTING (To be retained)	Light Blue
EXISTING (To be demolished)	Light Yellow

Building :AAA (PRADEEP KUMAR)

Floor Name	Total Built Up Area (Sq.mt.)	Proposed FAR Area (Sq.mt.) Resi.	Total FAR Area (Sq.mt.)	Total Consumed Additional FAR Area (Sq.mt.)	Tnmt (No.)
Ground Floor	85.89	85.89	85.89	85.89	01
First Floor	85.89	85.89	85.89	85.89	00
Terrace Floor	0.00	0.00	0.00	0.00	00
Total :	171.78	171.78	171.78	171.78	01
Total Number of Same Buildings	1				
Total :	171.78	171.78	171.78	171.78	01

SCHEDULE OF DOOR:

BUILDING NAME	NAME	LENGTH	HEIGHT	NOS
AAA (PRADEEP KUMAR)	D2	0.75	2.10	04
AAA (PRADEEP KUMAR)	D1	1.00	2.10	06
AAA (PRADEEP KUMAR)	D	1.20	2.10	01

SCHEDULE OF WINDOW/VENTILATION:

BUILDING NAME	NAME	LENGTH	HEIGHT	NOS
AAA (PRADEEP KUMAR)	V	0.60	0.50	04
AAA (PRADEEP KUMAR)	W1	1.20	1.20	01
AAA (PRADEEP KUMAR)	W	1.80	1.20	16

UnitBUA Table for Building :AAA (PRADEEP KUMAR)

FLOOR	Name	UnitBUA Type	UnitBUA Area	Carpet Area	No. of Rooms	No. of Tenement
GROUND FLOOR PLAN	SPLIT FLAT A	FLAT	139.87	135.28	6	1
AAA (PRADEEP KUMAR)	SPLIT FLAT A	FLAT	0.00	0.00	6	0
First Floor PLAN	-	-	139.87	135.28	12	1

Buildingwise Floor FAR Details

Floor Name	Building Name		Total	
	Proposed Built Up Area (Sq.mt.)	Proposed FAR Area (Sq.mt.)	Total Proposed Built Up Area (Sq.mt.)	Total FAR Area (Sq.mt.)
Ground Floor	85.89	85.89	85.89	85.89
First Floor	85.89	85.89	85.89	85.89
Terrace Floor	0.00	0.00	0.00	0.00
Total :	171.78	171.78	171.78	171.78

Building USE/SUBUSE Details

Building Name	Building Use	Building SubUse	Building Structure
AAA (PRADEEP KUMAR)	Residential	Bungalow/ Dwelling / Non Apartment	Non-Highrise

LTP NAME AND SIGNATURE	STRUCTURAL ENG'S NAME AND SIGNATURE	BUILDER NAME AND SIGNATURE	DIGITAL SIGNATURE
Amrendra Kumar KONPC/SUP/0002/2017			