

GROUND FLOOR PLAN (Proposed) (SCALE 1:100)

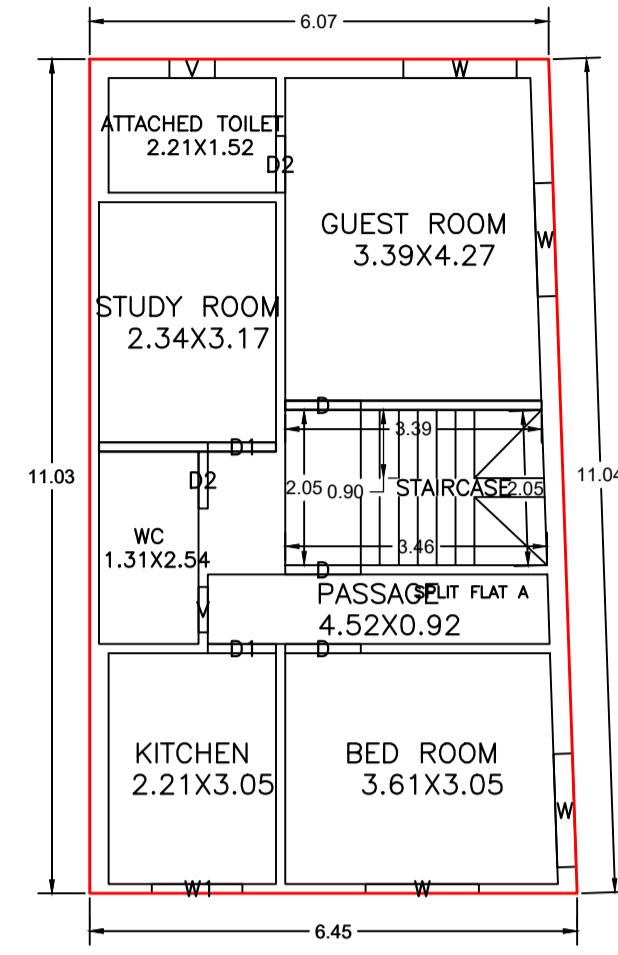

TYPICAL - 1 & 2 FLOOR PLAN (Proposed) (SCALE 1:100)

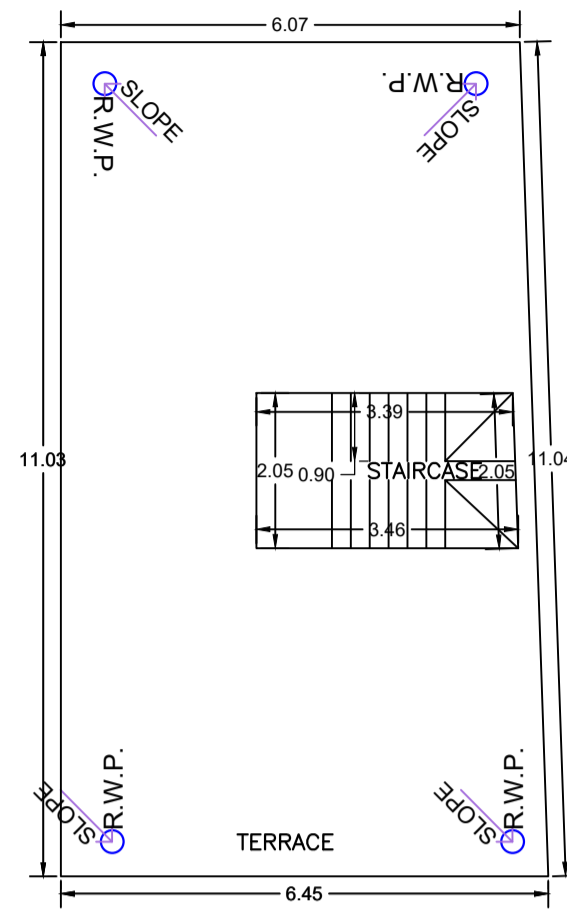

TERRACE FLOOR PLAN (SCALE 1:100)

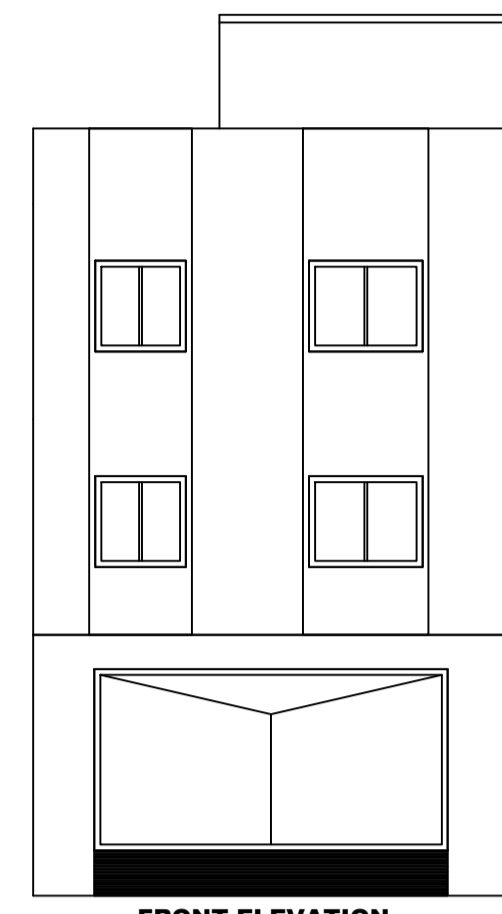

FRONT ELEVATION (SCALE - 1:100)

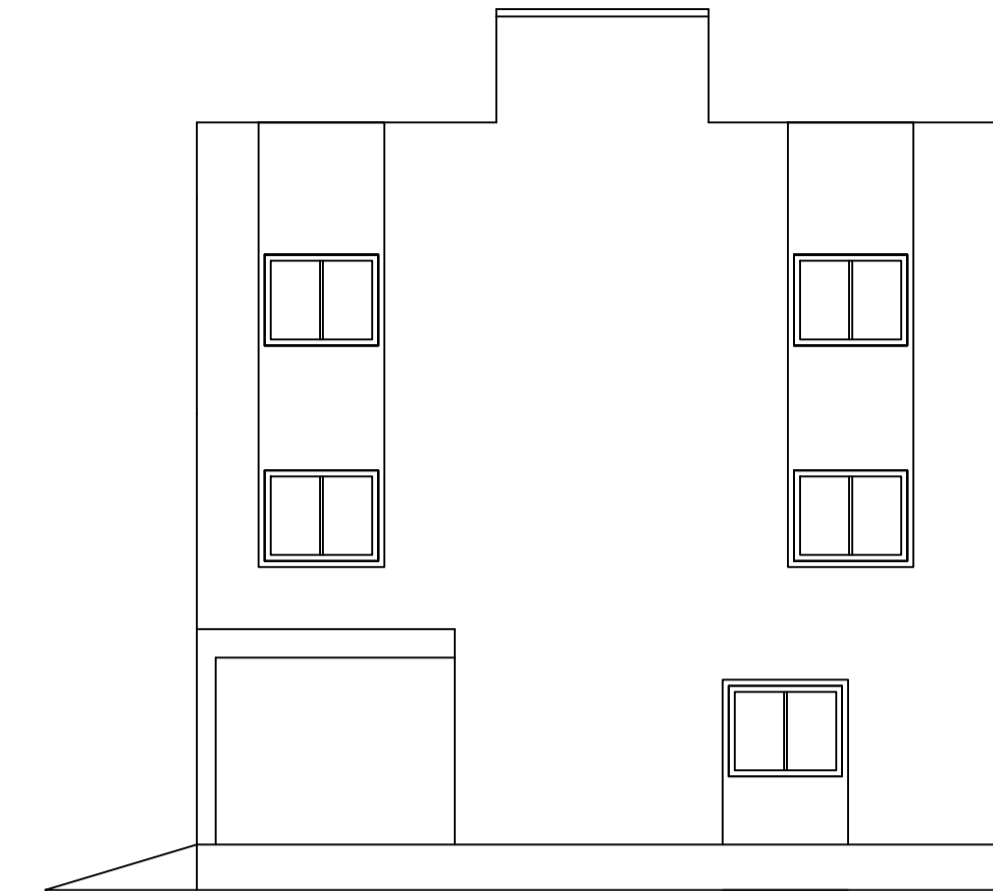

SIDE ELEVATION (SCALE - 1:100)

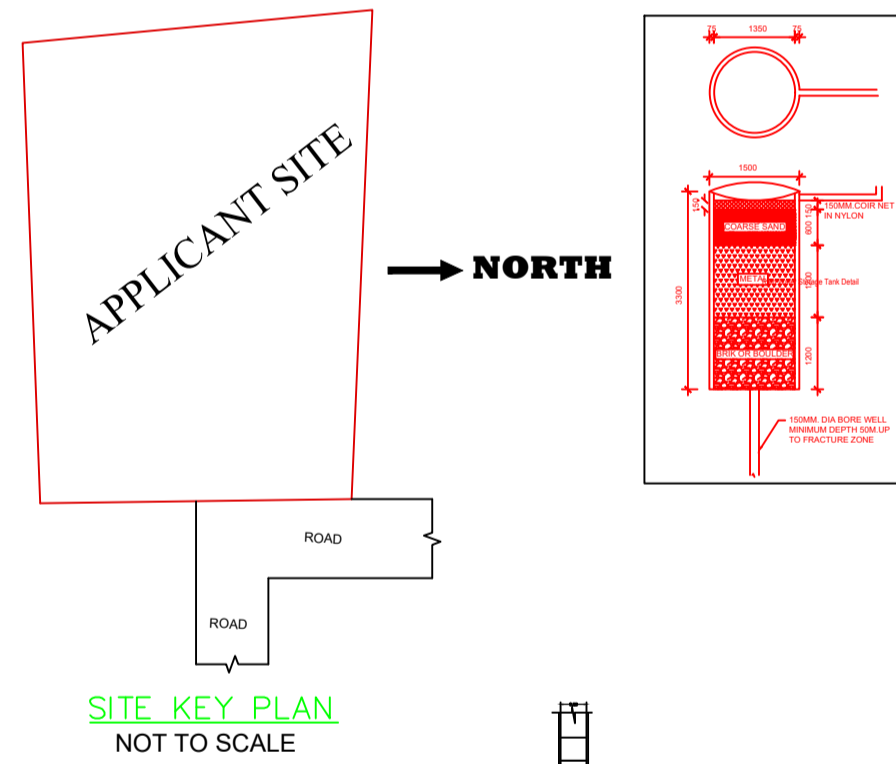
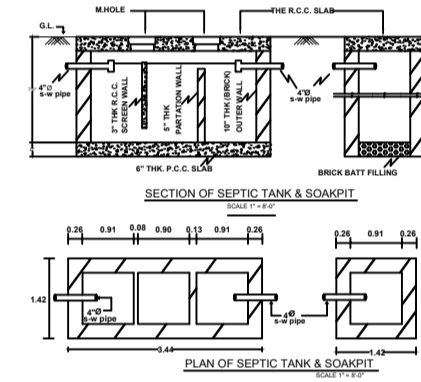

SITE KEY PLAN NOT TO SCALE

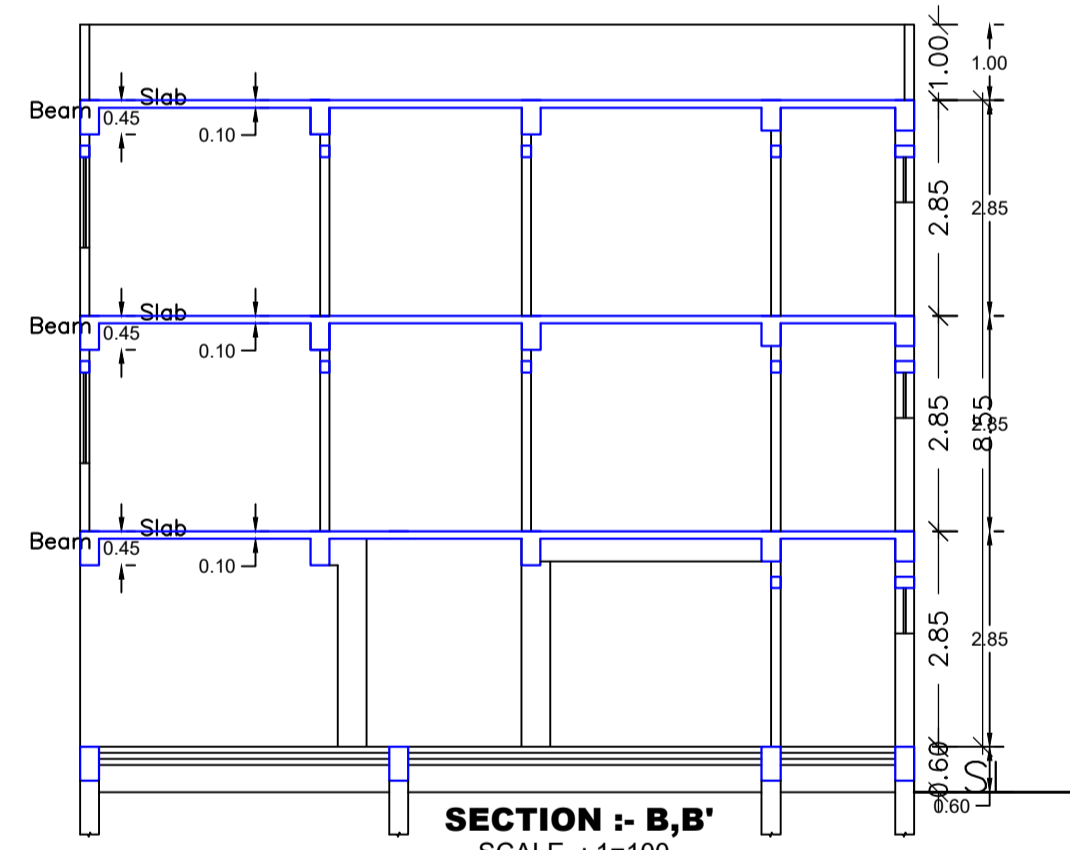

SECTION - B,B' (SCALE - 1:100)

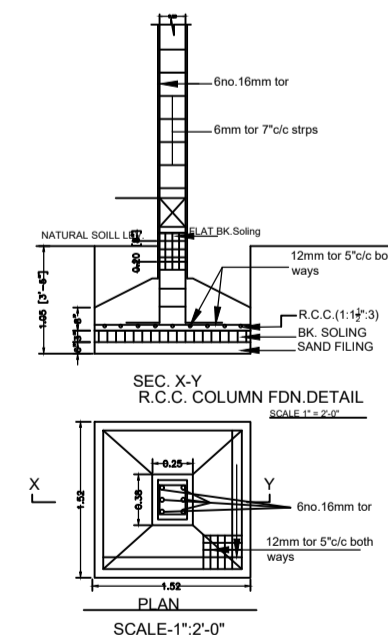

SCALE - 1:20

Building USE/SUBUSE Details

Building Name	Building Use	Building SubUse	Building Structure	Floor Name	Floor Use	Floor SubUse	FAR Name	FAR Use	FAR SubUse
AA (1 SRI SURESH PRASAD YADAV 2 SRI SANTOSH KUMAR ANAND)	Residential	Bungalow/ Dwelling / Non Apartment	Non-Highrise	GROUND FLOOR PLAN	Residential	Bungalow/ Dwelling / Non Apartment	Residential FAR	Residential	Bungalow/ Dwelling / Non Apartment
				TYPICAL - 1 & 2 FLOOR PLAN	Residential	Bungalow/ Dwelling / Non Apartment	Residential FAR	Residential	Bungalow/ Dwelling / Non Apartment
				TERRACE FLOOR PLAN	Residential	Bungalow/ Dwelling / Non Apartment	-	-	-

FAR & Tenement Details (Table 4c-1)

Building	No. of Same Bldg	Total Built Up Area (Sq.mt.)	Deductions (Area in Sq.mt.)	Proposed FAR Area (Sq.mt.)	Total FAR Area (Sq.mt.)	Total Consumed Additional FAR Area (Sq.mt.)	Tnmt (No.)
AA (1 SRI SURESH PRASAD YADAV 2 SRI SANTOSH KUMAR ANAND)	1	207.21	39.02	168.19	168.19	168.19	01
Grand Total :	1	207.21	39.02	168.19	168.19	168.19	01

COLOR INDEX

PLOT BOUNDARY	Black
ABUTTING ROAD	Red
PROPOSED CONSTRUCTION	Green
COMMON PLOT	Yellow
ROAD WIDENING AREA	Blue
EXISTING (To be retained)	Orange
EXISTING (To be demolished)	Pink

Building :AA (1 SRI SURESH PRASAD YADAV 2 SRI SANTOSH KUMAR ANAND)

Floor Name	Total Built Up Area (Sq.mt.)	Deductions (Area in Sq.mt.)	Proposed FAR Area (Sq.mt.)	Total FAR Area (Sq.mt.)	Total Consumed Additional FAR Area (Sq.mt.)	Tnmt (No.)
Ground Floor	69.07	39.02	30.05	30.05	30.05	01
First Floor	69.07	0.00	69.07	69.07	69.07	00
Second Floor	69.07	0.00	69.07	69.07	69.07	00
Terrace Floor	0.00	0.00	0.00	0.00	0.00	00
Total :	207.21	39.02	168.19	168.19	168.19	01

Buildingwise Floor FAR Details

Floor Name	Building Name		Total	
	Proposed Built Up Area (Sq.mt.)	Proposed FAR Area (Sq.mt.)	Total Proposed Built Up Area (Sq.mt.)	Total FAR Area (Sq.mt.)
Ground Floor	69.07	30.05	69.07	30.05
First Floor	69.07	69.07	69.07	69.07
Second Floor	69.07	69.07	69.07	69.07
Terrace Floor	0.00	0.00	0.00	0.00
Total :	207.21	168.19	207.21	168.19

Proposal Basic Information

Proposal File No.	KONPC/BP/0039/W10/2024
Owner Name	1 SRI SURESH PRASAD YADAV 2 SRI SANTOSH KUMAR ANAND
Khata No	294
Plot No	3668
Village Name	Kodarma
Use	Residential
SubUse	Bungalow/ Dwelling / Non Apartment

AREA STATEMENT		VERSION NO. : 1.0.73
KODERMA NAGAR PANCHAYAT		VERSION DATE: 16/10/2020
PROJECT DETAIL:		
Region: JHARKHAND URBAN LOCAL BODIES	Plot Use: Residential	
District: KODERMA	Plot SubUse: Bungalow/ Dwelling / Non Apartment	
Authority: KODERMA NAGAR PANCHAYAT	PlotNearby/ReligiousStructure: NA	
Inward No: KONPC/BP/0039/W10/2024	Plot/SubPlot No: 3668	
Application Type: General Proposal	North: Plot No. - NIJ VENDEE & PLOT NO-3668	
Project Type: Building Permission	South: Plot No. - PLOT NO-3670	
Nature of Development: New	East: Road Width - 3.66M WIDE ROAD & SULOCHANA PANDEY	
Location of Development Area: Old Area	West: Plot No. - PLOT NO-3669	
AREA DETAILS:		
AREA OF PLOT (Minimum)	(A)	SQ.MT.
NET AREA OF PLOT(Gross Plot Area - Deduction from Gross Plot area)	(A-Deductions)	117.21
Deduction for Balance Plot Area(from Gross Plot Area)		
Common Plot		11.70
Total		11.70
BALANCE AREA OF PLOT(Net Plot Area - Recreational/Amenity space)	(A-Deductions)	105.51
PLOT AREA FOR COVERAGE(Net Plot Area)	(A-Deductions)	117.21
Plot Area for FAR (Net Plot Area + RoadWidening Area)	(A-Deductions)	117.21
COVERAGE CHECK		
Permissible Coverage area (70.00 %)		82.05
Proposed Coverage Area (58.93 %)		69.07
Total Prop. Coverage Area (58.93 %)		69.07
Balance coverage area (11.07 %)		12.98
FAR CHECK		
Perm. FAR Area (1.500)		175.82
Total Perm. FAR area		175.82
Residential FAR		168.20
Proposed FAR Area		168.20
Total Proposed FAR Area		168.20
Consumed FAR (Factor)		1.44
Balance FAR Area		7.62
BUILT UP AREA CHECK		
Total Proposed Built Up Area		207.21
ARCHITECT (Regd)		
ENGINEER (Regd)		MD SHOAB ALAM
SUPERVISOR (Regd)		
OWNER (Regd)		1 SRI SURESH PRASAD YADAV 2 SRI SANTOSH KUMAR ANAND
DEVELOPMENT AUTHORITY		
		LOCAL BODY

UnitBUA Table for Building :AA (1 SRI SURESH PRASAD YADAV 2 SRI SANTOSH KUMAR ANAND)

FLOOR	Name	UnitBUA Type	UnitBUA Area	Carpet Area	No. of Rooms	No. of Tenement
GROUND FLOOR PLAN	SPLIT FLAT A	FLAT	130.82	130.05	2	1
TYPICAL - 1 & 2 FLOOR PLAN	SPLIT FLAT A	FLAT	0.00	0.00	7	0
Total:			130.82	130.05	16	1

SCHEDULE OF DOOR:

BUILDING NAME	NAME	LENGTH	HEIGHT	NOS
AA (1 SRI SURESH PRASAD YADAV 2 SRI SANTOSH KUMAR ANAND)	D2	0.75	2.10	05
AA (1 SRI SURESH PRASAD YADAV 2 SRI SANTOSH KUMAR ANAND)	D1	0.90	2.10	04
AA (1 SRI SURESH PRASAD YADAV 2 SRI SANTOSH KUMAR ANAND)	D	1.00	2.10	07

SCHEDULE OF WINDOW/VENTILATION:

BUILDING NAME	NAME	LENGTH	HEIGHT	NOS
AA (1 SRI SURESH PRASAD YADAV 2 SRI SANTOSH KUMAR ANAND)	V	0.60	0.60	05
AA (1 SRI SURESH PRASAD YADAV 2 SRI SANTOSH KUMAR ANAND)	W1	1.20	1.20	03
AA (1 SRI SURESH PRASAD YADAV 2 SRI SANTOSH KUMAR ANAND)	W	1.50	1.20	09

LTP NAME AND SIGNATURE	STRUCTURAL ENG'S NAME AND SIGNATURE	BUILDER NAME AND SIGNATURE	DIGITAL SIGNATURE
MD SHOAB ALAM KONPC/ENG/0004/2017			