

Project Title : MOHAMMED ZAINUL

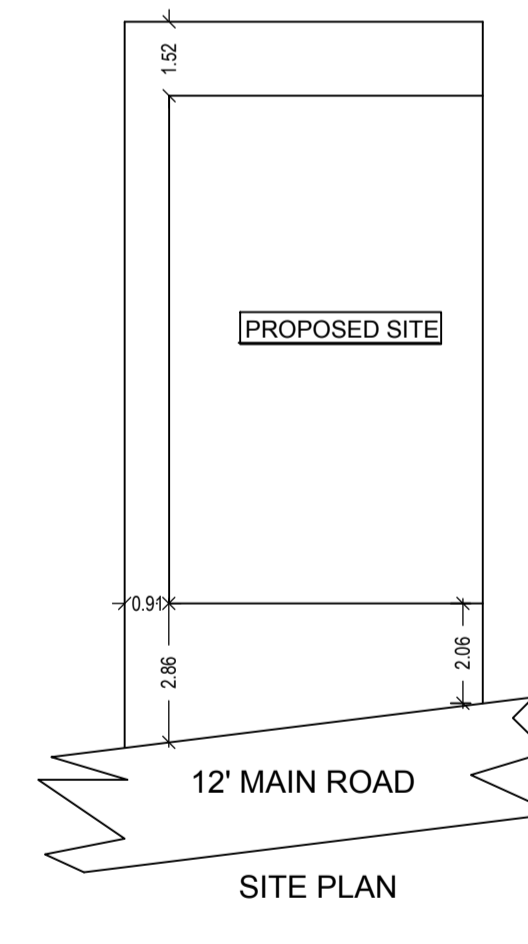
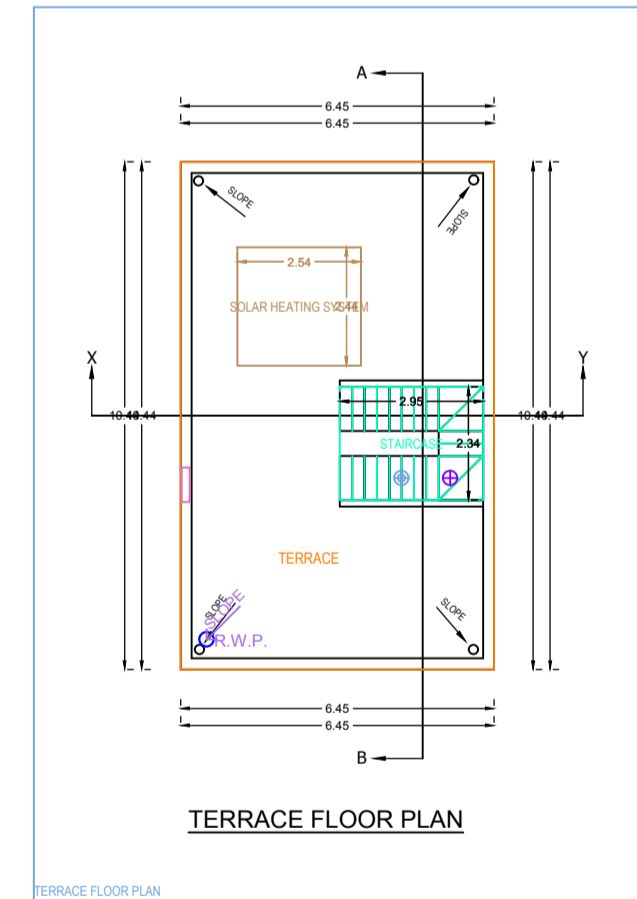
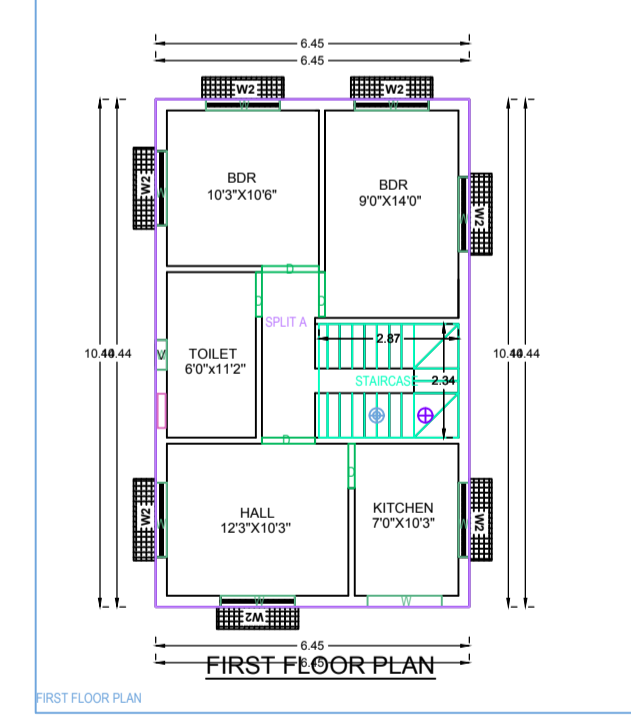
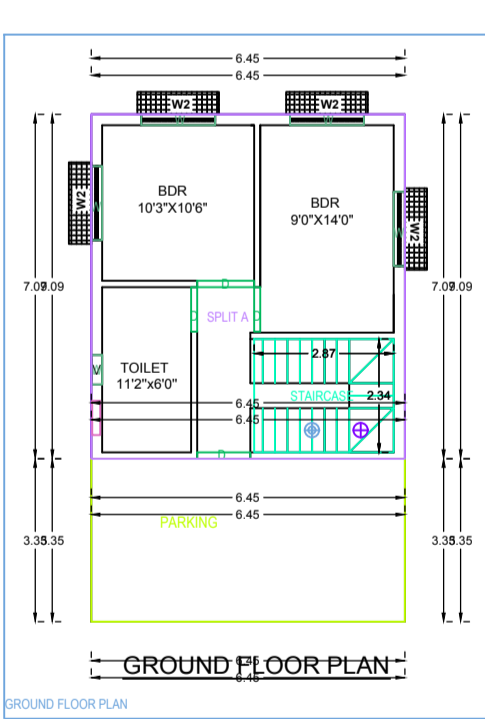
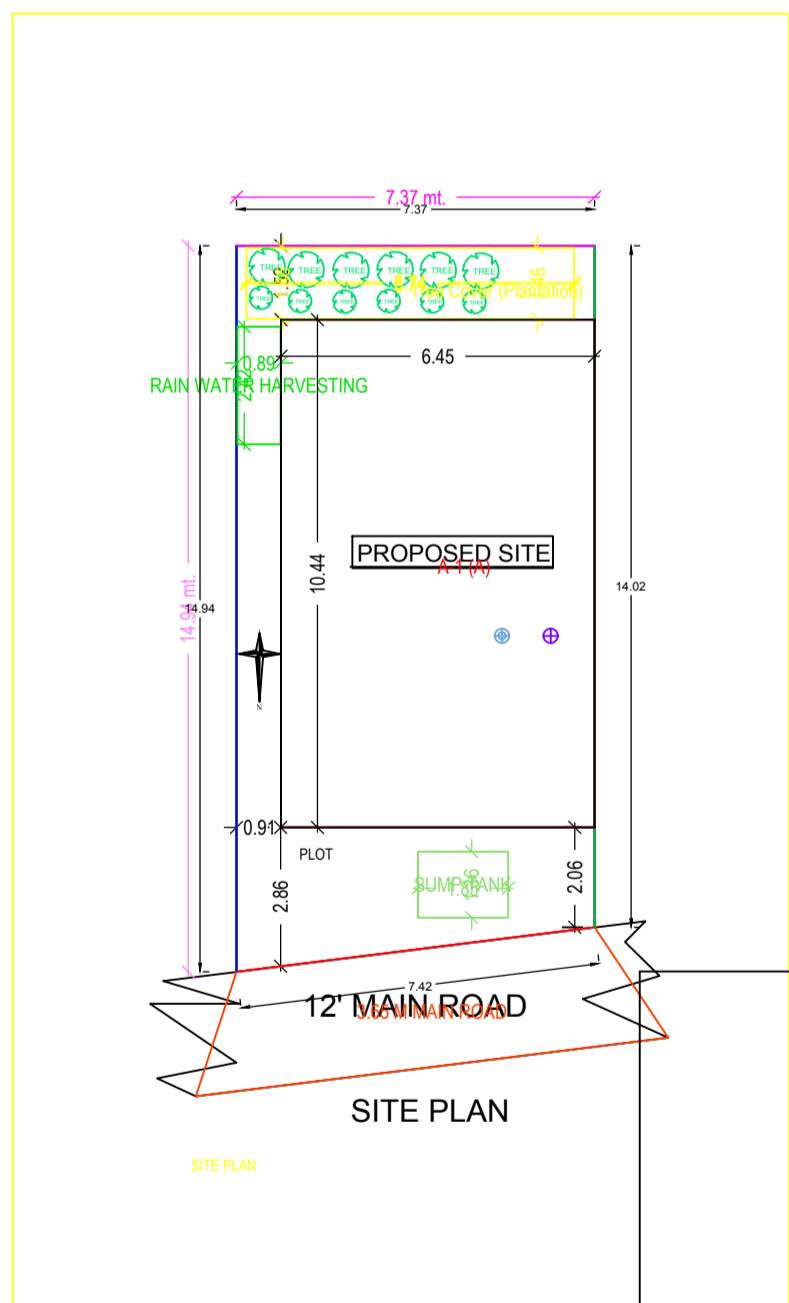
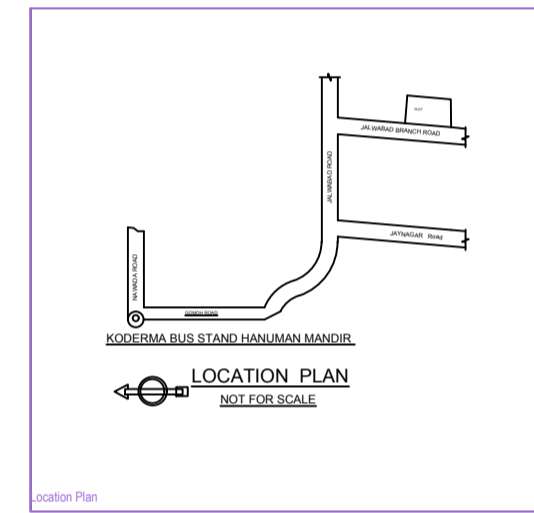
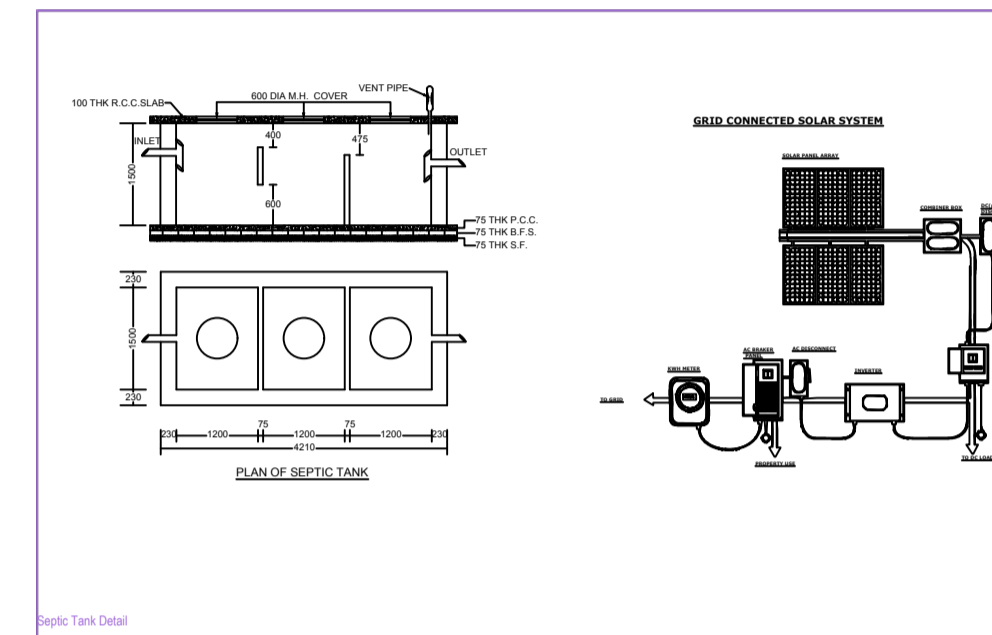
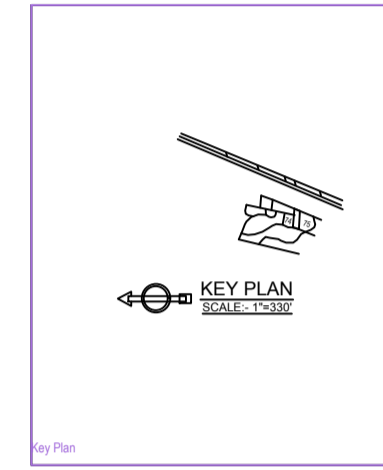
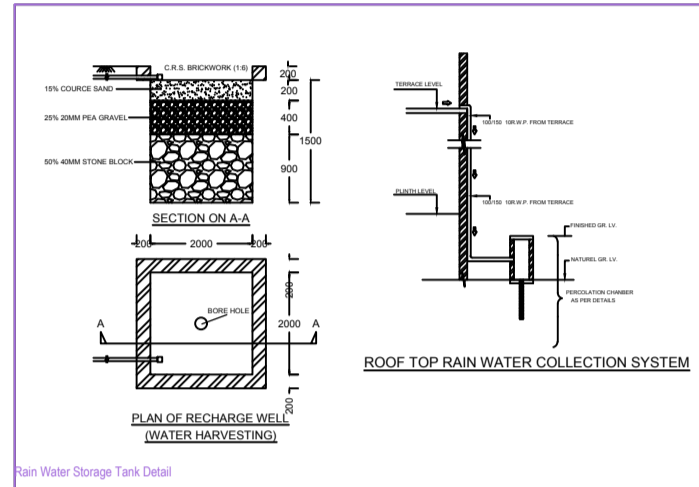
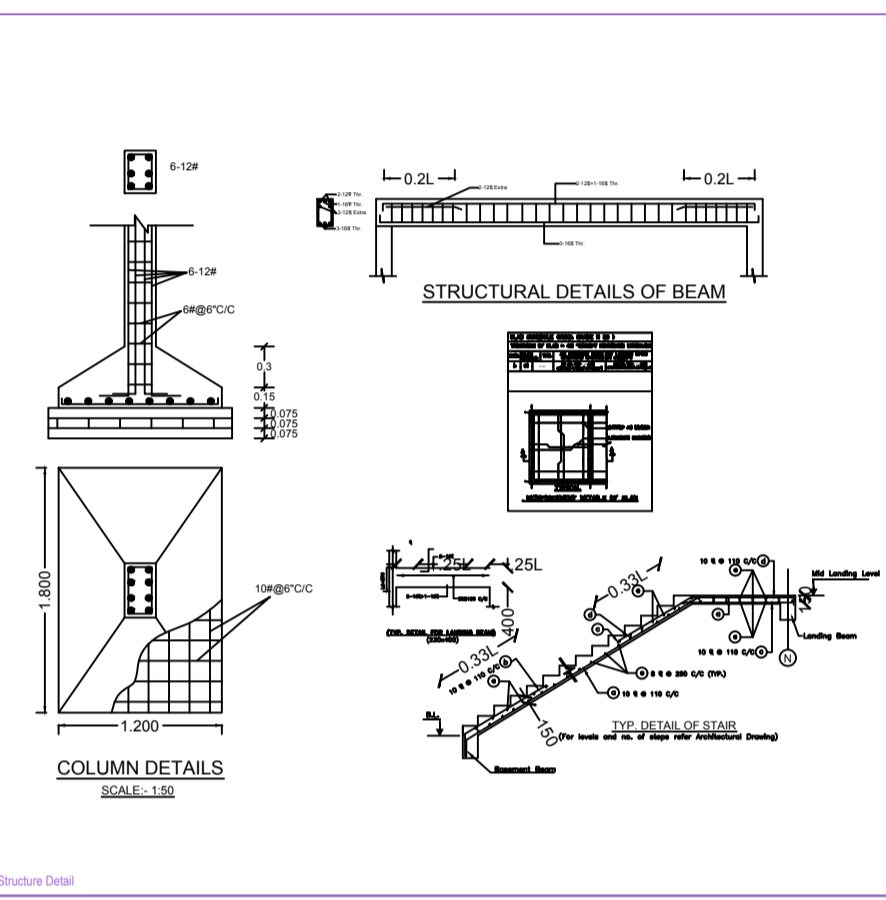
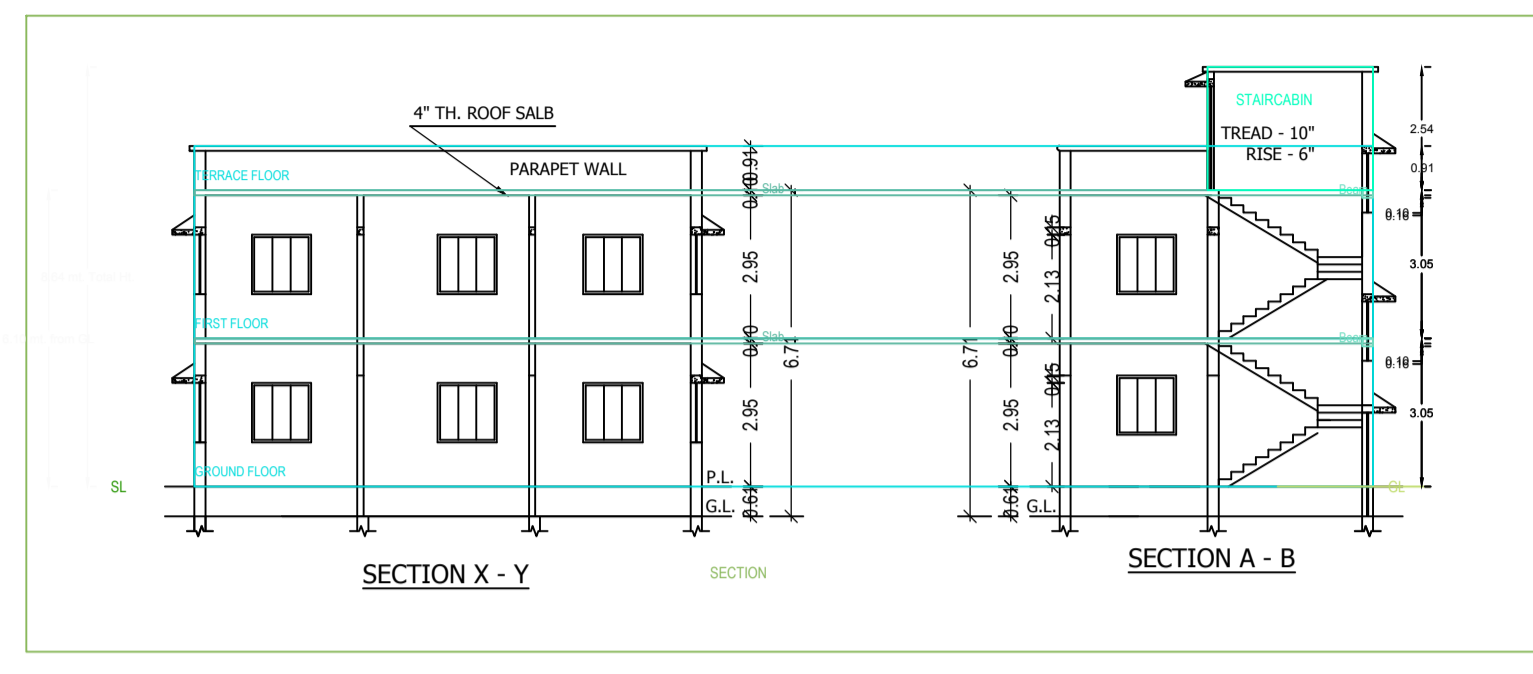
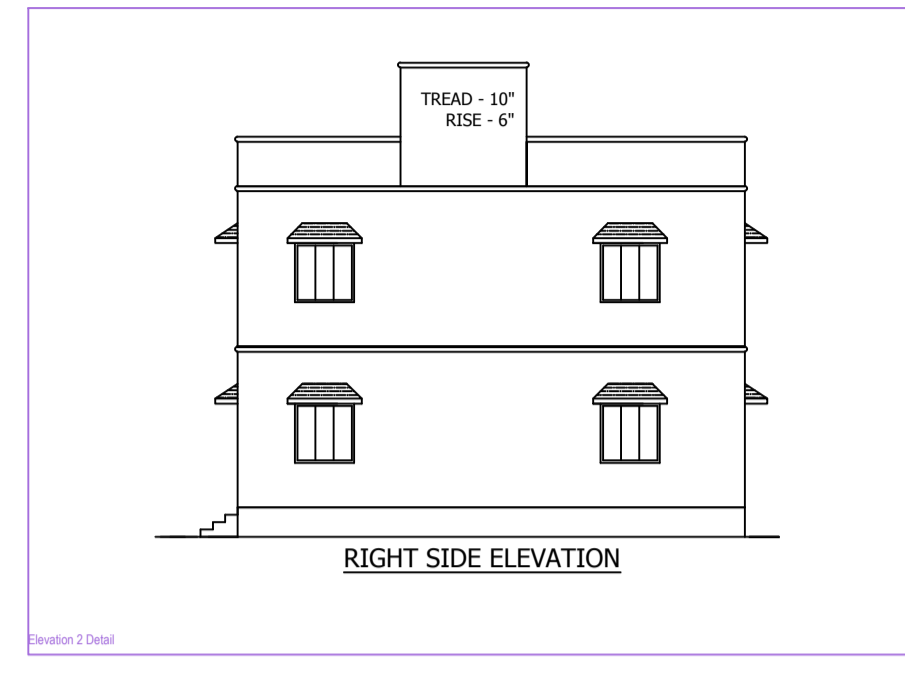
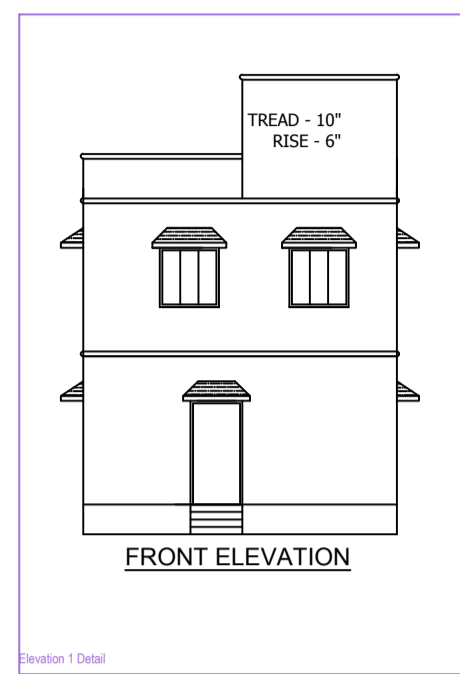

PROJECT DETAIL	VERSION NO. 1.0/37
Project No. :-	VERSION DATE: 16/10/2020
Region :- KHARWAH URBAN LOCAL BODIES	Plot Use - Residential
Location :- KODERMA	Plot Sub-Use - Bungalow/Dwelling / Non-Apartment
Application Type :- General Proposal	Land Use Zone - Residential
Project Type :- Building Permission	Plot No. :-
Nature of Development :- New	Survey No./Survey No. :-
Location :- Old Area	Thana No. :-
Sub-Location :- NA	Plotting No. :-
Ward/Area Name :-	Chana No. :-
Ward No. :-	North :-
Road/Street :-	East :-
	West :-

AREA DETAILS	AREA OF PLOT (Minimum)	(A)	SQ.MT	136.70
Net Plot Area (Gross Plot Area - Deduction from Gross Plot Area)	(A) Deductions		136.70	
Deductions for Balance Plot Area (from Gross Plot Area)				
COF Area			9.81	
Total			9.81	
Balance Plot Area (Net Plot Area - Recreational/amenity space)	(A) Deductions		96.88	
Plot Area for Coverage (Net Plot Area)	(A) Deductions		136.70	
Plot Area for ISI (Net Plot Area + Road/Watering Area)	(A) Deductions		136.70	
COVERAGE CHECK				
Proposed Coverage Area (83.15 %)			67.38	
Total Coverage Area (83.15 %)			67.38	
FAR CHECK				
Proposed Area of FAR			113.12	
Total Area of FAR			113.12	
BUILT UP AREA CHECK				
Total Proposed Builtup Area			134.77	
ARCHITECT / SUPERVISOR (Regd)			OWNER	
DEVELOPMENT AUTHORITY			LOCAL BODY	

COLOR INDEX	
PLOT BOUNDARY	Black
ABUTTING ROAD	Red
PROPOSED WORK (COVERAGE AREA)	Green
EXISTING (To be retained)	Blue
EXISTING (To be demolished)	Yellow

COLOR INDEX	
PLOT BOUNDARY	Black
ABUTTING ROAD	Red
PROPOSED WORK (COVERAGE AREA)	Green
EXISTING (To be retained)	Blue
EXISTING (To be demolished)	Yellow

Parking Type	Prop No.	Prop Area
Other Parking	1	21.65
Total Area		21.65

MARGIN DETAIL:					
Building / Wing Name	Road Name	Front Margin	Rear Margin	Side Margin	Side Margin
A/A	3.65 M (MAIN ROAD)	2.05	1.52	0.91	0.90

Building Name	No. of Same Bldg	Total Built Up Area (Sq.Mt)	Deduction Area (Sq.Mt)	Proposed FAR Area (Sq.Mt)	Total FAR Area (Sq.Mt)	Tent (No.)
A/A	1	134.77	21.65	113.12	113.12	01
Grand Total	1	134.77	21.65	113.12	113.12	01

BRIEF SPECIFICATION

STRUCTURE - Earthquake Resistant R.C.C. Frame Structure.
FOUNDATION - R.C.C. (1:1.5:3) M20 Grade Column Footing Foundation.
PLINTH/BEAM - 15" R.C.C. (1:1.5:3) m-20, all round at Basement floor and Plinth Level.
SUPERSTRUCTURE - First class brick work in cement mortar (1:6) and Plinth Level.
SLAB, BEAM & LINTEL - All R.C.C. Frame Structure (1:1.5:3) M-20 Grade Concrete.
FLOORING - Finish with Marble/Vitrified Tiles over 15mm base / 25mm thk. First class I.P.S. Flooring (1" x 2").
DOOR - All door frames are full wood & panels of 30mm thk. water resistant flush Door.
WINDOW - All Windows are of steel glazed / Aluminium frame work.
PLASTERING - 12mm Thk. cement plaster (1:6) on both face of wall & 6mm Thk. C.M. (1:4) in ceiling.
WALL FINISHING - (A) Interior wall finish with P.O.P. & Primer.
 (B) Exterior walls of building will be putty finish / weather coat / Snowcum
SANITARY WATER SUPPLY - All works as per IS Specification & fittings of ISI mark only.
ANTI TERMITES - Treatment of Foundation soil.
STEEL - Fe-500 Grade TMT Bar shall be used.
CEMENT - 43 IS Grade Cement of standard Brand.
SAND / AGGREGATE - As per IS specification.

NOTE:
 (A) - All above work should be done as per IS specification and items used of ISI Mark only.
 (B) - All R.C.C. Structure / Foundation should be design after proper soil investigation.
 (C) - All work should be done in direction / supervision of experienced & Authorised Engineer.

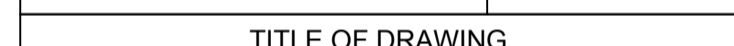

TITLE OF DRAWING
 PLAN OF PROPOSED RESIDENTIAL BUILDING OF MOHAMMED ZAINUL, W/O BARATAN MIYAN OF NAGARKHARA JALWABAD KODERMA, P.S.-KODERMA, THE PART OF PLOT NO. 74, 75, KHATA NO. - 10, MOUZA NO. - NAGARKHARA NO. - 329 IN THE DISTRICT OF KODERMA.
 J H A R K H A N D

SIGNATURE OF OWNER

SIGNATURE OF ENGINEER

SCALE :- 1: .100 SHEET :- 1 OF 1

Floor Name	Total Built Up Area (Sq.Mt)	Deductions Area (P.S.P.H.T. Parking)	Proposed FAR Area (Sq.Mt)	Total FAR Area (Sq.Mt)	Tent (No.)
Ground Floor	67.39	21.65	45.74	45.74	01
First Floor	67.38	0.00	67.38	67.38	00
Terrace Floor	0.00	0.00	0.00	0.00	00
Total	134.77	21.65	113.12	113.12	01
Total Number of Same Buildings	1				
Total	134.77	21.65	113.12	113.12	01

BUILDING NAME	NAME	LENGTH	HEIGHT	NOS
A/A	D	0.91	2.10	00
A/A	D	1.08	2.10	00
A/A	D	1.17	2.10	00
Total				00

BUILDING NAME	NAME	LENGTH	HEIGHT	NOS
A/A	W	0.63	1.20	02
A/A	W	1.52	1.20	02
Total				04

FLOOR	Name	Unit/BUA Type	Unit/BUA Area	Carpet Area	No. of Rooms	No. of Tenement
GROUND FLOOR PLAN	SPLIT A	FLAT	113.12	112.88	4	1
Total			113.12	112.88	10	1