

Proposal Basic Information	
Proposal File No	KONPC/BI/0027/W06/2024
Owner Name	PRAMOD KUMAR
Khata No	381
Plot No	1063
Village Name	Kodarma
Use	Residential
SubUse	Bungalow/ Dwelling / Non Apartment

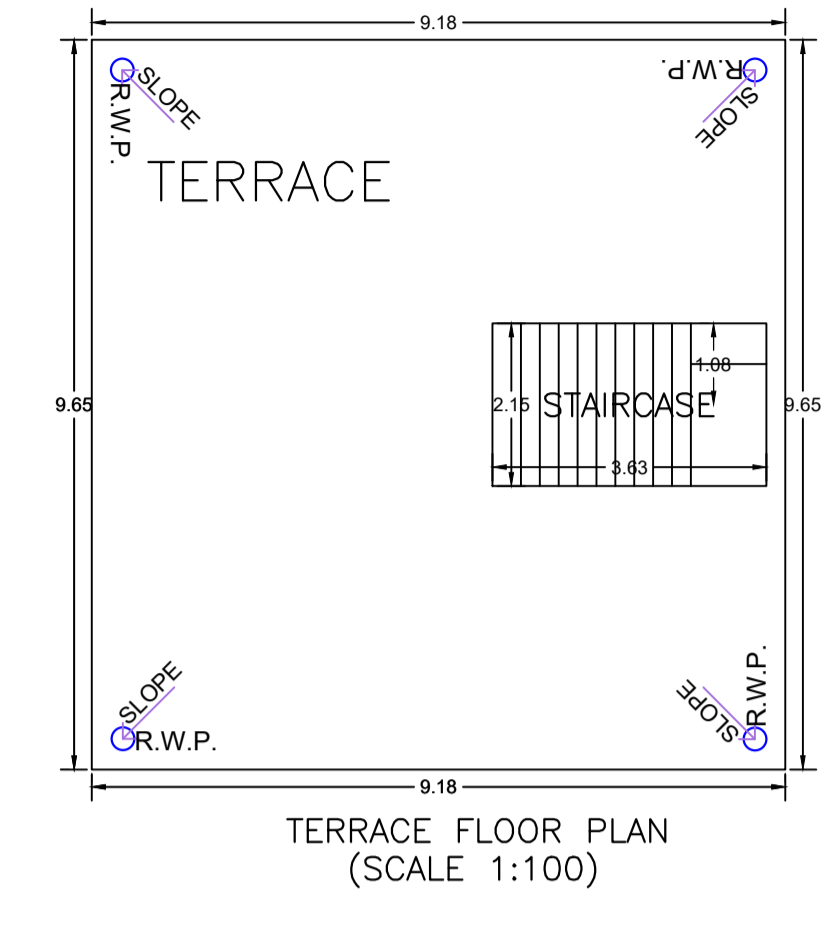
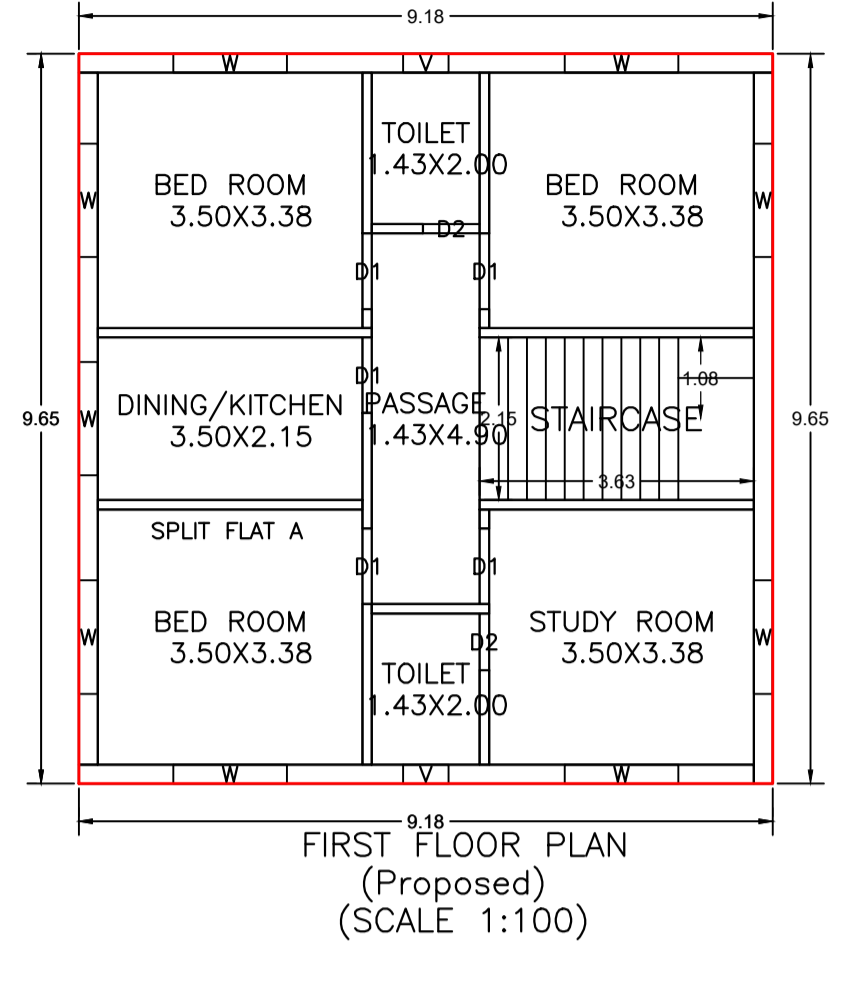
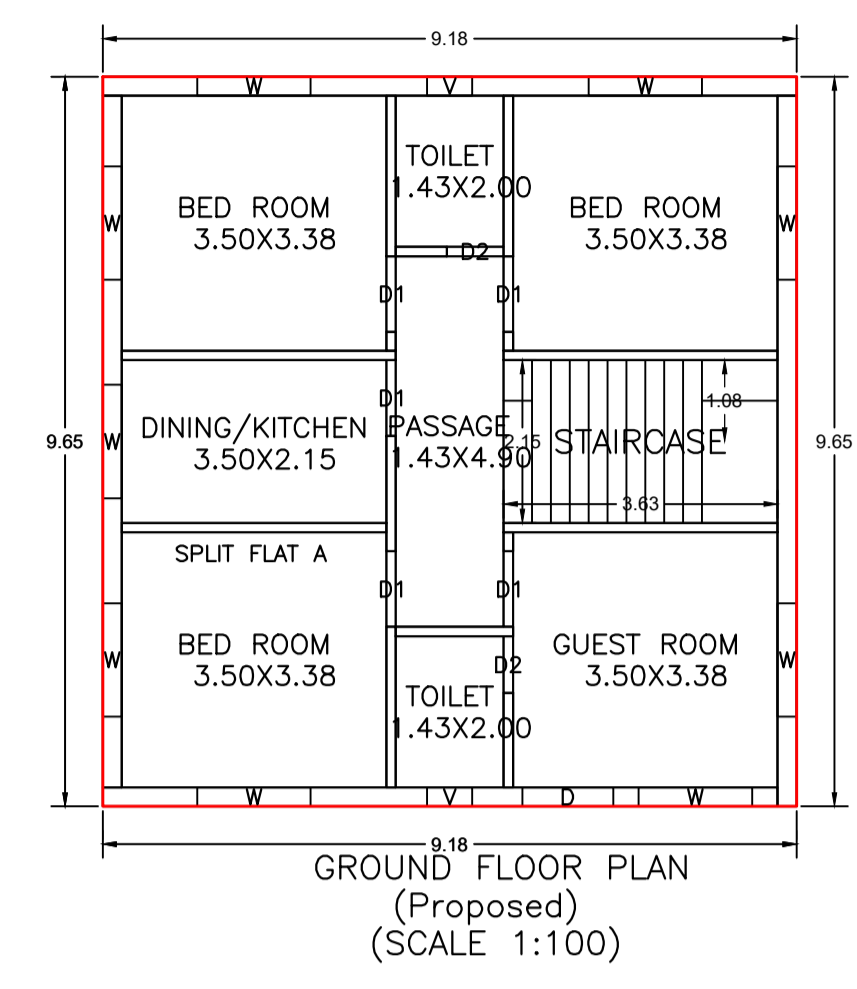
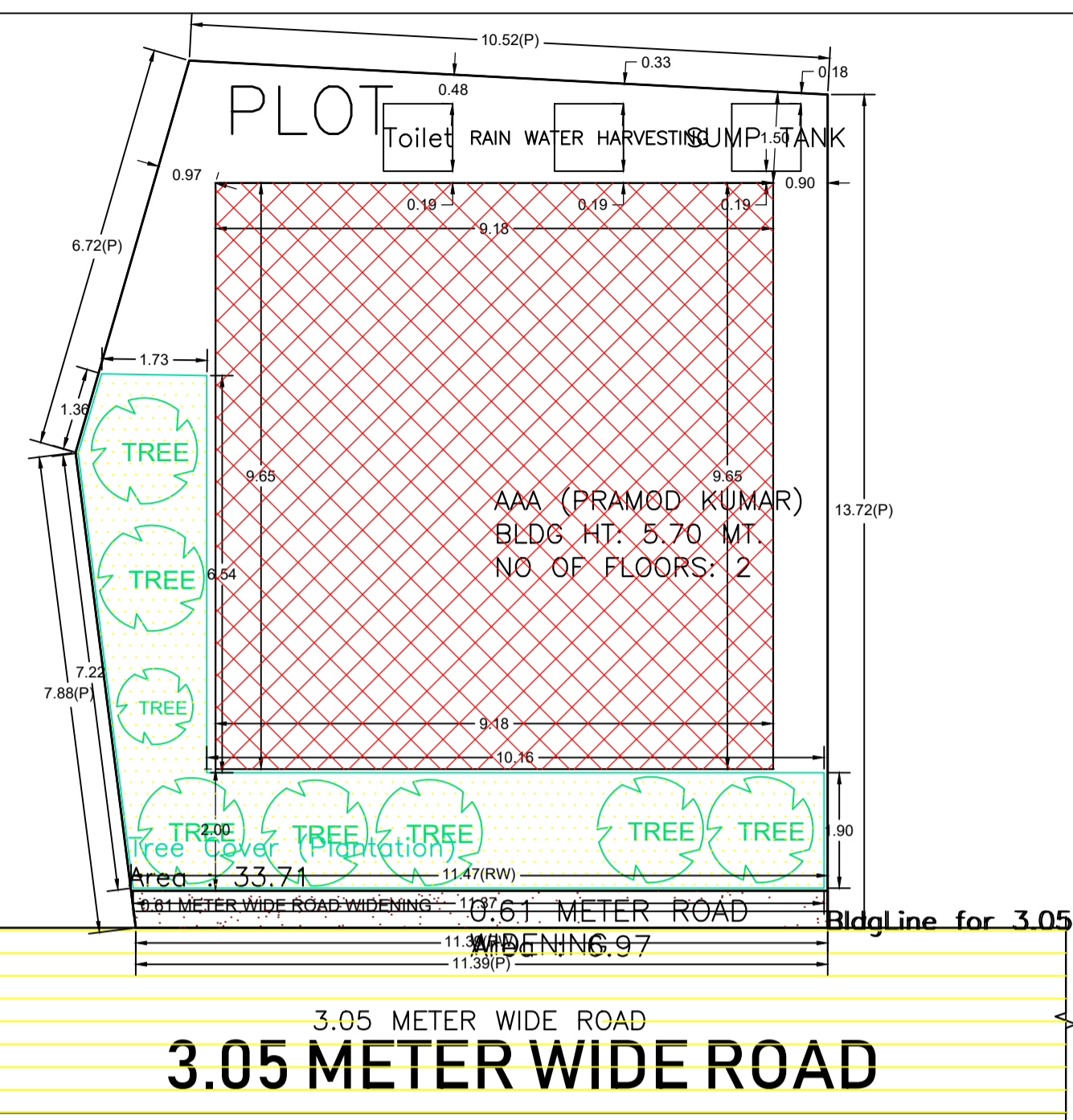

AREA STATEMENT	
KODERMA NAGAR PANCHAYAT	VERSION NO.: 1.0.70
PROJECT DETAIL:	VERSION DATE: 16/10/2020
Region: JHARKHAND URBAN LOCAL BODIES	Plot Use: Residential
District: KODERMA	Plot SubUse: Bungalow/ Dwelling / Non Apartment
Authority: KODERMA NAGAR PANCHAYAT	PlotNearby/ReligiousStructure: NA
Inward No: KONPC/BI/0027/W06/2024	Plot/SubPlot No: 1063
Application Type: General Proposal	North: Plot No. - POONA MINYAN
Project Type: Building Permission	South: Plot No. - NUJ
Nature of Development: New	East: Plot No. - PLOT 1061
Location of Development Area: Old Area	West: Road Width - 3.05M

AREA DETAILS:		SQ.MT.
AREA OF PLOT (Minimum)	(A)	156.90
Deduction for NetPlot Area		
Road Widening Area		6.97
Total		6.97
NET AREA OF PLOT(Gross Plot Area - Deduction from Gross Plot area)	(A-Deductions)	149.93
Deduction for Balance Plot Area(from Gross Plot Area)		
Road Widening Area		6.97
Common Plot		33.71
Total		40.68
BALANCE AREA OF PLOT(Net Plot Area - Recreational/Amenity space)	(A-Deductions)	116.22
PLOT AREA FOR COVERAGE(Net Plot Area)	(A-Deductions)	149.93
Plot Area for FAR (Net Plot Area + RoadWidening Area)	(A-Deductions)	149.93

COVERAGE CHECK		
Permissible Coverage area ( 70.00 % )		104.95
Proposed Coverage Area ( 59.08 % )		88.58
Total Prop. Coverage Area ( 59.08 % )		88.58
Balance coverage area ( 10.92 % )		16.37

FAR CHECK		
Perm. FAR Area ( 1.200 )		179.92
Total Perm. FAR area		179.92
Residential FAR		177.15
Proposed FAR		177.15
Total Proposed FAR Area		177.15
Consumed FAR (Factor)		1.18
Balance FAR Area		2.77

BUILT UP AREA CHECK		
Total Proposed BuiltUp Area		177.16
ARCHITECT (Regd)	Amrendra Kumar	
ENGINEER (Regd)		
SUPERVISOR (Regd)		
OWNER (Regd)	PRAMOD KUMAR	
DEVELOPMENT AUTHORITY	LOCAL BODY	

Buildingwise Floor FAR Details				
Floor Name	Building Name		Total	
	Proposed Built Up Area (Sq.mt.)	Proposed FAR Area (Sq.mt.)	Total Proposed Built Up Area (Sq.mt.)	Total FAR Area (Sq.mt.)
Ground Floor	88.58	88.58	88.58	88.58
First Floor	88.58	88.58	88.58	88.58
Terrace Floor	0.00	0.00	0.00	0.00
Total :	177.16	177.16	177.16	177.16

Building USE/SUBUSE Details				
Building Name	Building Use	Building SubUse	Building Structure	
AAA (PRAMOD KUMAR)	Residential	Bungalow/ Dwelling / Non Apartment	Non-Highrise	

SITE PLAN

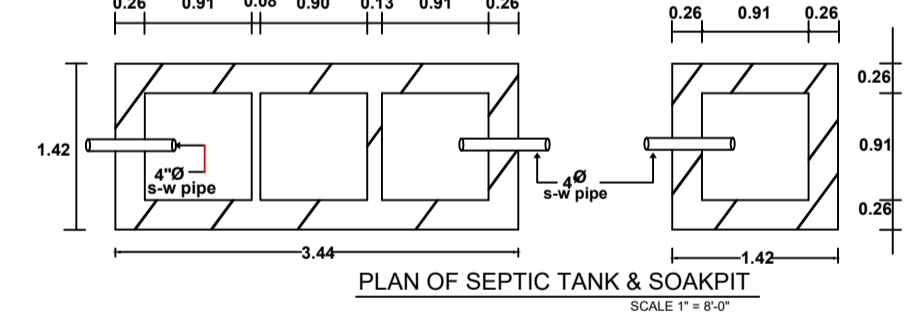
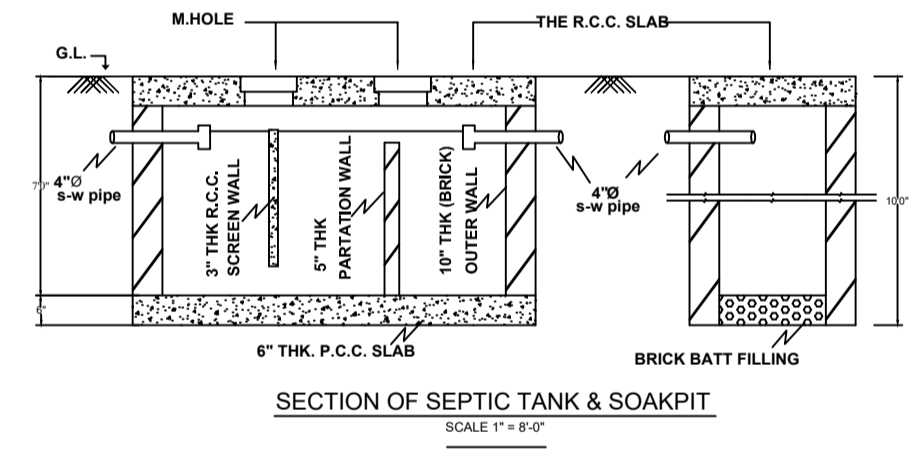
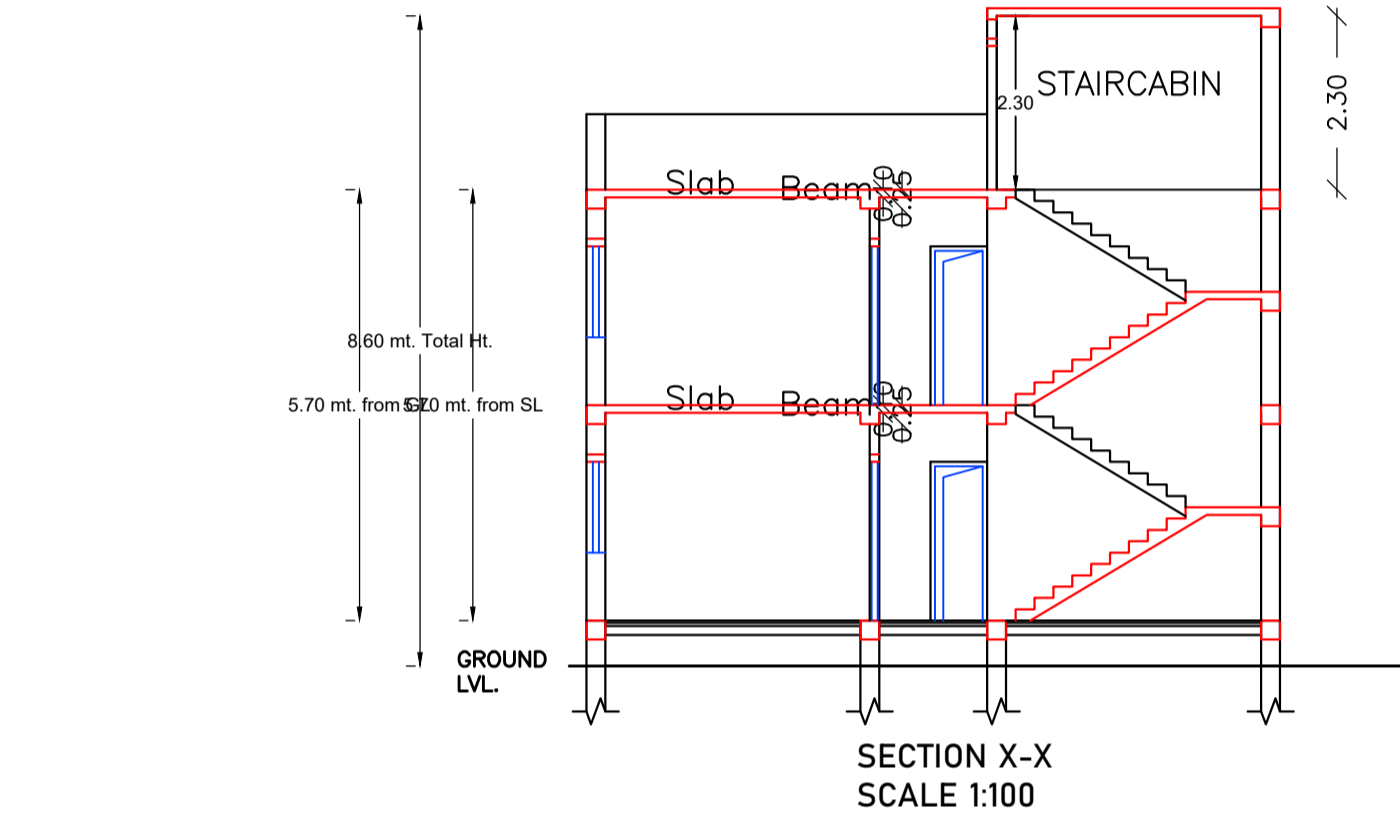
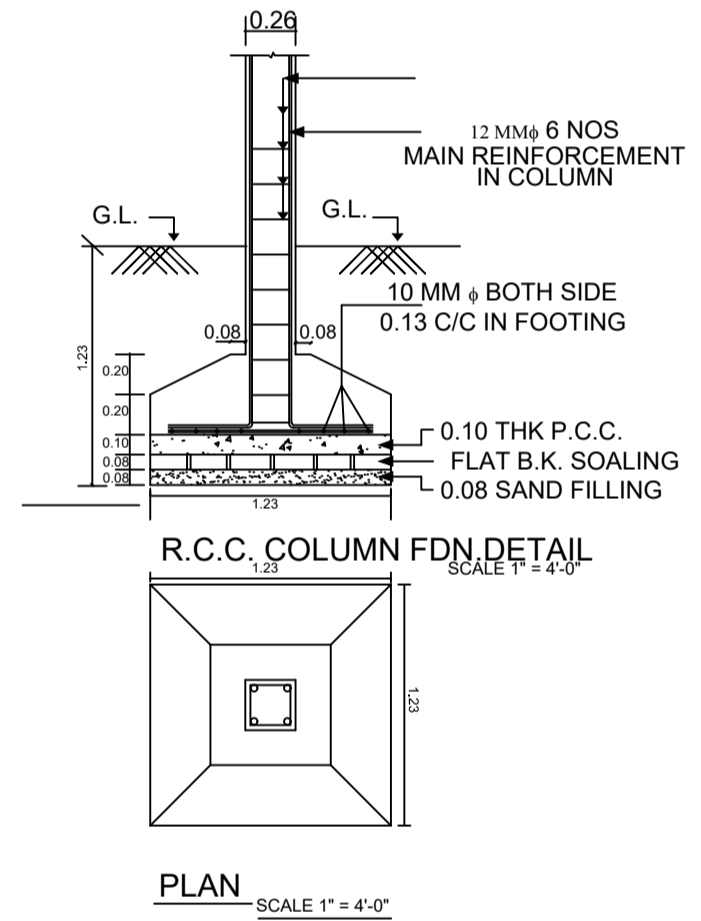
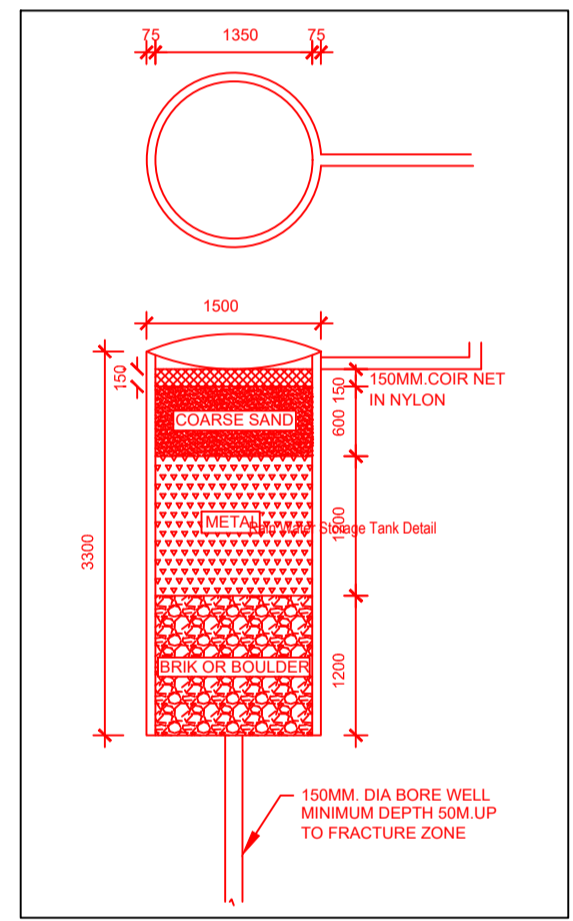

APPLICANT SITE



UnitBUA Table for Building :AAA (PRAMOD KUMAR)

FLOOR	Name	UnitBUA Type	UnitBUA Area	Carpet Area	No. of Rooms	No. of Tenement
GROUND FLOOR PLAN	SPLIT FLAT A	FLAT	142.32	136.60	8	1
FIRST FLOOR PLAN	SPLIT FLAT A	FLAT	0.00	0.00	8	0
Total:	-	-	142.32	136.60	16	1

SCHEDULE OF DOOR:

BUILDING NAME	NAME	LENGTH	HEIGHT	NOS
AAA (PRAMOD KUMAR)	D2	0.75	2.10	04
AAA (PRAMOD KUMAR)	D1	1.00	2.10	10
AAA (PRAMOD KUMAR)	D	1.20	2.10	01

SCHEDULE OF WINDOW/VENTILATION:

BUILDING NAME	NAME	LENGTH	HEIGHT	NOS
AAA (PRAMOD KUMAR)	V	0.60	0.50	04
AAA (PRAMOD KUMAR)	W	1.50	1.20	18

Building :AAA (PRAMOD KUMAR)

Floor Name	Total Built Up Area (Sq.mt.)	Proposed FAR Area (Sq.mt.)	Total FAR Area (Sq.mt.)	Total Consumed Additional FAR Area (Sq.mt.)	Tnmt (No.)
Ground Floor	88.58	88.58	88.58	88.58	01
First Floor	88.58	88.58	88.58	88.58	00
Terrace Floor	0.00	0.00	0.00	0.00	00
Total :	177.16	177.16	177.16	177.16	01
Total Number of Same Buildings :	1				
Total :	177.16	177.16	177.16	177.16	01

FAR & Tenement Details (Table 4c-1)

Building	No. of Same Bldg	Total Built Up Area (Sq.mt.)	Proposed FAR Area (Sq.mt.)	Total FAR Area (Sq.mt.)	Total Consumed Additional FAR Area (Sq.mt.)	Tnmt (No.)
AAA (PRAMOD KUMAR)	1	177.16	177.16	177.16	177.16	01
Grand Total :	1	177.16	177.16	177.16	177.16	01

LTP NAME AND SIGNATURE	STRUCTURAL ENG'S NAME AND SIGNATURE	BUILDER NAME AND SIGNATURE	DIGITAL SIGNATURE
Amrendra Kumar KONPC/SUP/0002/2017			