

SITE PLAN

AREA STATEMENT (DHANBAD MUNICIPAL CORPORATION)		VERSION NO.: T.Q.12	VERSION DATE: 14/06/2017
PROJECT DETAIL :			
Region: JHARKHAND URBAN LOCAL BODIES	Plot Use: Residential		
District: DHANBAD	Plot SubUse: Residential Bldg/Apartment		
Authority: DHANBAD MUNICIPAL CORPORATION	PlotNearbyReligiousStructure: NA		
Inward No: DMC/BP/0020/W20/2017	Plot/SubPlot No: 302		
Application Type: General Proposal	North: Road Width - 1.21 (drain)		
Project Type: Building Permission	South: Road Width - 3.04		
Nature of Development: New	East: Plot No. - plot of kumari sandhya das		
Location of Development Area: Old Area	West: Road Width - 3.65		
AREA DETAILS :			
AREA OF PLOT (Minimum)	(A)	SQ.MT.	272.03
NET AREA OF PLOT(Gross Plot Area - Deduction from Gross Plot area)	(A-Deductions)		272.03
Deduction for Balance Plot Area(from Gross Plot Area)			
Common Plot			34.39
BALANCE AREA OF PLOT(Net Plot Area - Recreational/Amenity space)	(A-Deductions)		237.63
PLOT AREA FOR COVERAGE(Net Plot Area)	(A-Deductions)		272.03
Plot Area for FAR (Net Plot Area + Road Widening Area)	(A-Deductions)		272.03
COVERAGE CHECK			
Permissible Coverage area (60.00 %)			163.22
Proposed Coverage Area (58.39 %)			158.84
Total Prop. Coverage Area (58.39 %)			158.84
Balance coverage area (1.61 %)			4.38
FAR CHECK			
Perm. FAR Area (1.50)			408.04
Total Perm. FAR area			408.04
Residential FAR			320.67
Proposed FAR Area			320.67
Total Proposed FAR Area			320.67
Consumed FAR (Factor)			1.18
Balance FAR Area			87.37
BUILT UP AREA CHECK			
Total Proposed BuiltUp Area			320.67
ARCHITECT (Regd)		AMARENDRA KUMAR	
ENGINEER (Regd)			
SUPERVISOR (Regd)			
OWNER (Regd)		Smt Kumari Shivani	
DEVELOPMENT AUTHORITY		LOCAL BODY	

COLOR INDEX	
PLOT BOUNDARY	Black
ABUTTING ROAD	Green
PROPOSED CONSTRUCTION	Red
COMMON PLOT	Yellow
ROAD WIDENING AREA	Light Yellow
EXISTING (To be retained)	Blue
EXISTING (To be demolished)	Light Blue

Buildingwise Floor FAR Details

Floor Name	Building Name		Total	
	A (SMT KUMARI SHIVANI)		Total Proposed Built Up Area (Sq.mt.)	Total FAR Area (Sq.mt.)
Ground Floor	158.84	158.84	158.84	158.84
First Floor	161.83	161.83	161.83	161.83
Terrace Floor	0.00	0.00	0.00	0.00
Total :	320.67	320.67	320.67	320.67

Building Use/SUBUSE Details

Building Name	Building Use	Building SubUse	Building Structure
A (SMT KUMARI SHIVANI)	Residential	Residential Bldg/Apartment	Non-Highrise

FAR & Tenement Details (Table 4c-1)

Building	No. of Same Bldg	Total Built Up Area (Sq.mt.)	Proposed FAR Area (Sq.mt.)		Total Consumed Additional FAR Area (Sq.mt.)	Tnmt (No.)
			Resi.	Total FAR Area (Sq.mt.)		
A (SMT KUMARI SHIVANI)	1	320.67	320.67	320.67	320.67	01
Grand Total :	1	320.67	320.67	320.67	320.67	1.00

LTP NAME AND SIGNATURE	STRUCTURAL ENG'S NAME AND SIGNATURE	BUILDER NAME AND SIGNATURE
AMARENDRA KUMAR DMC/ENG/0009/2016		

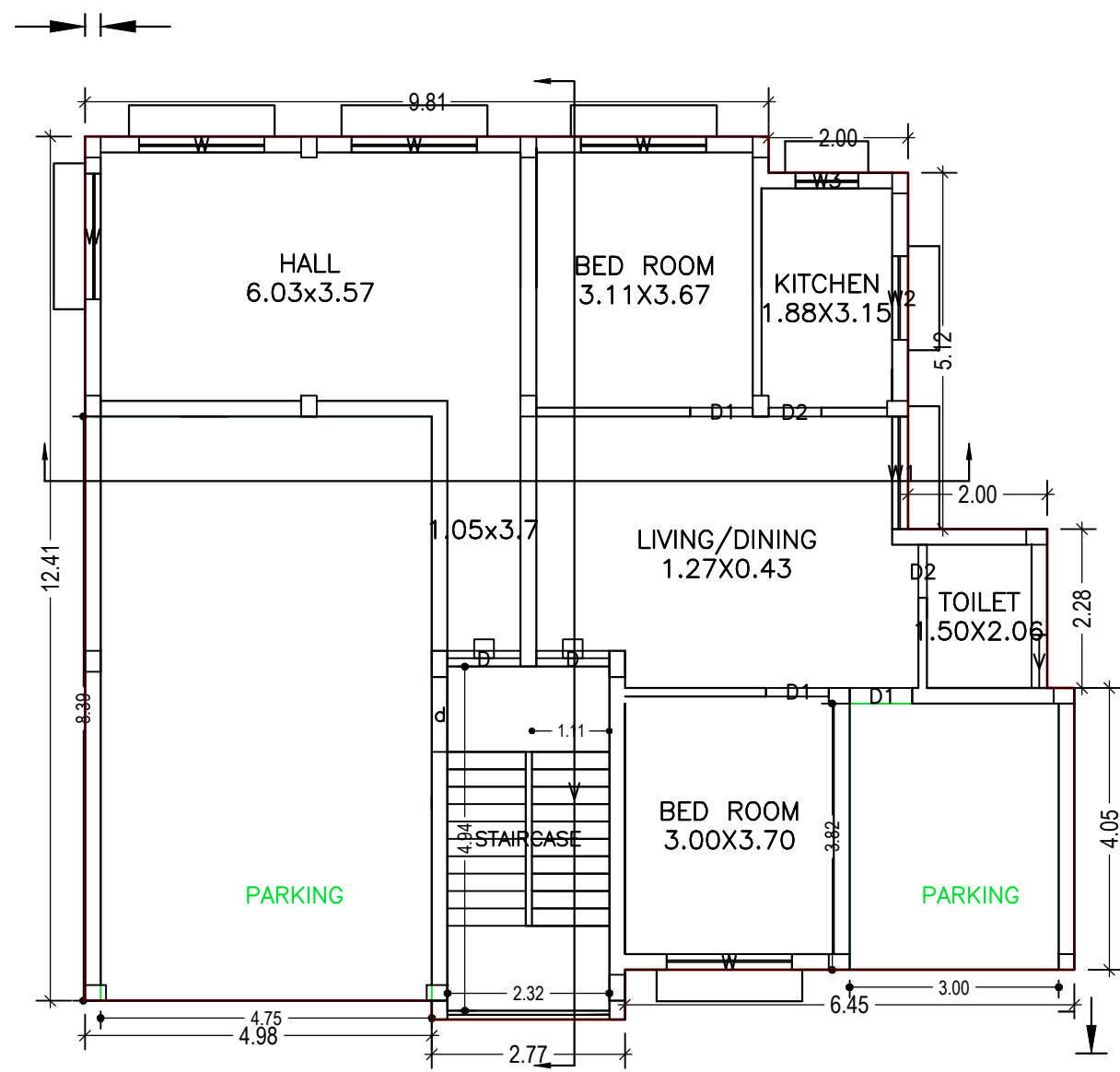

GROUND FLOOR PLAN
(Proposed)
(SCALE 1:100)

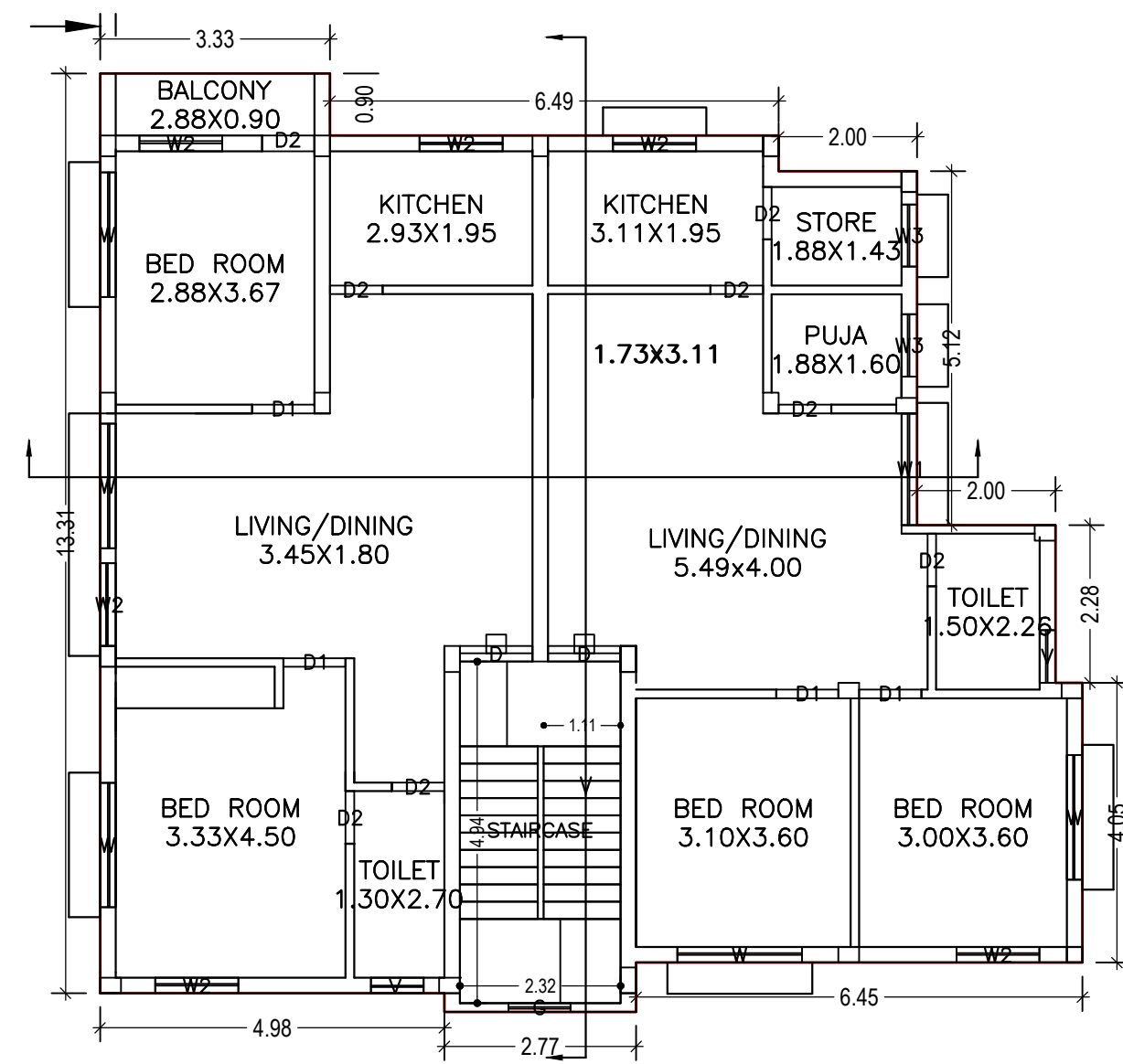

FIRST FLOOR PLAN
(Proposed)
(SCALE 1:100)

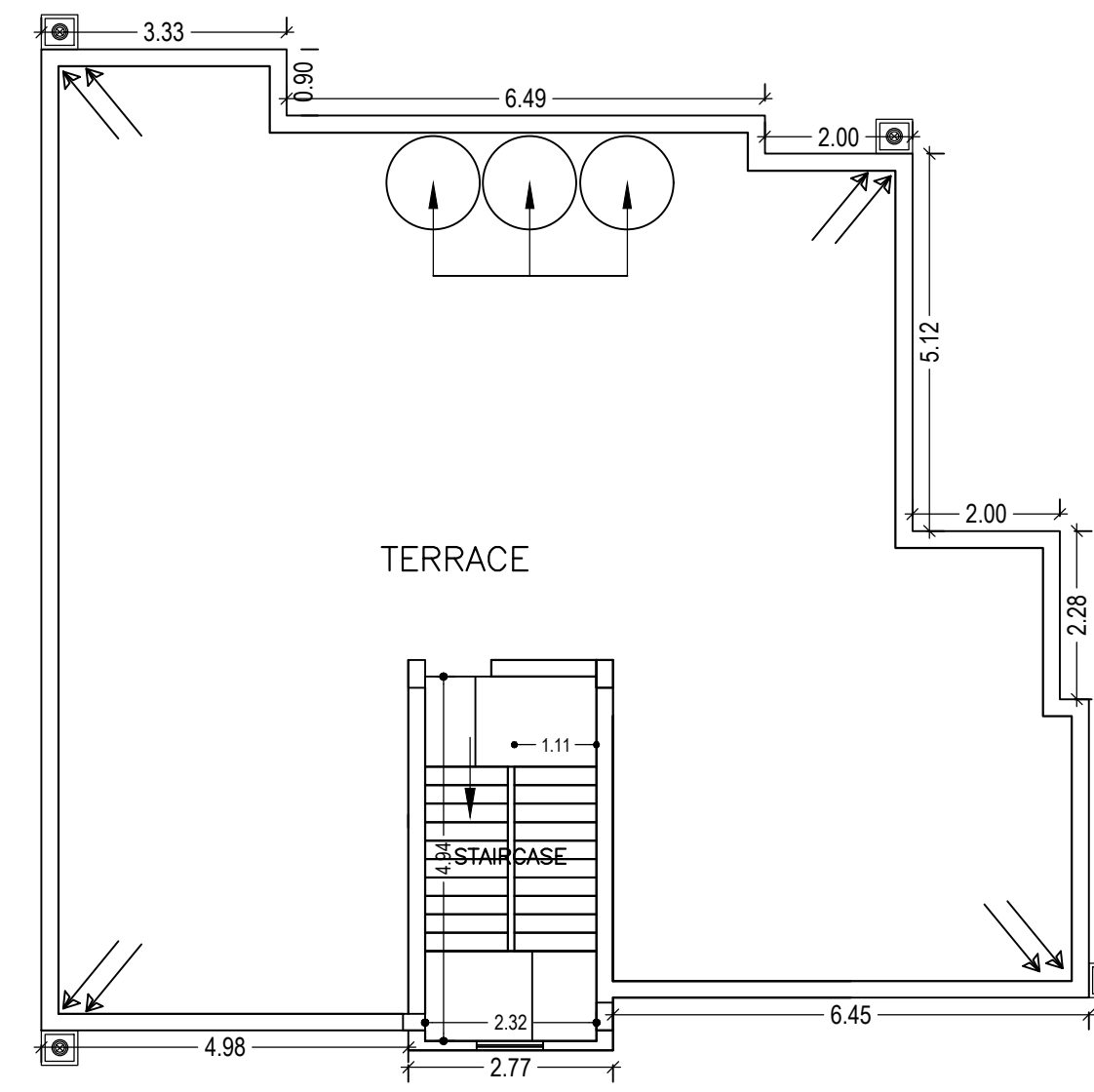

TERRACE FLOOR PLAN
(SCALE 1:100)

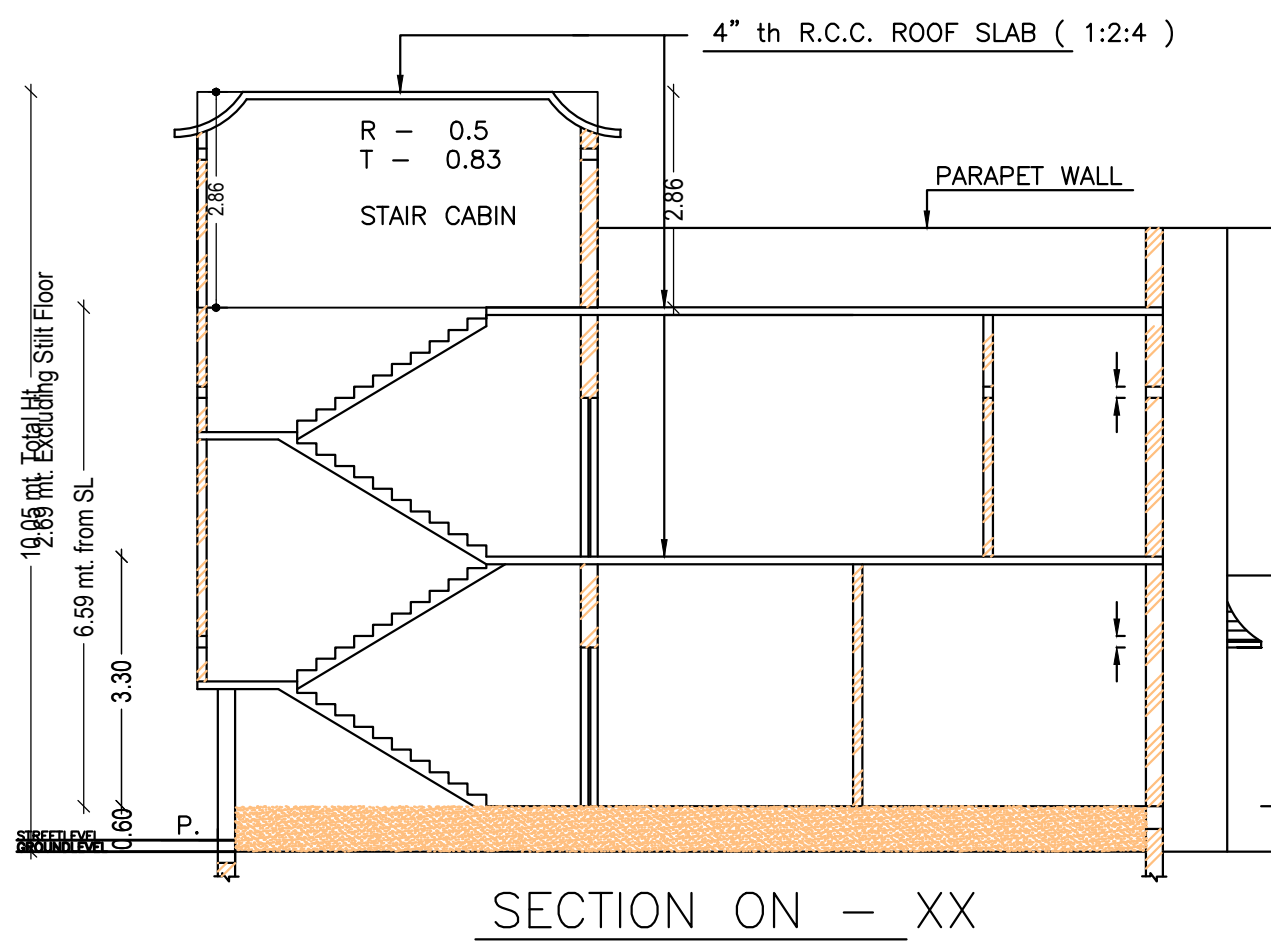
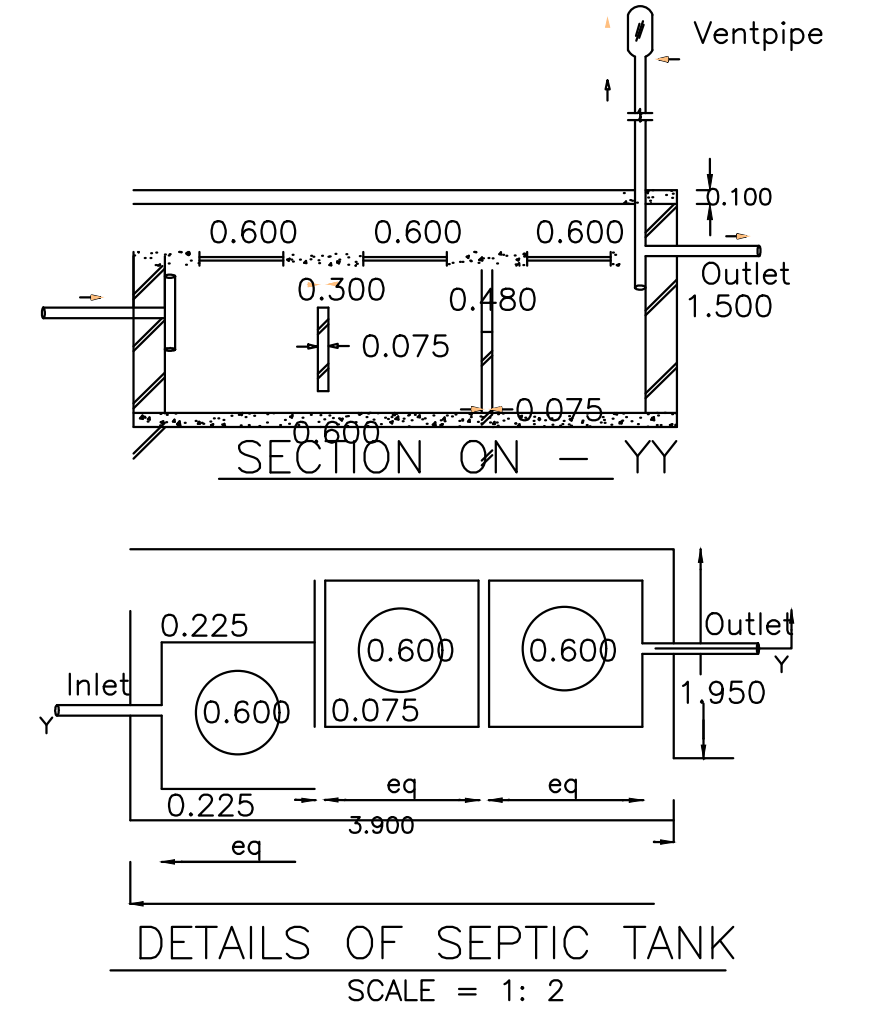

SECTION ON - XX

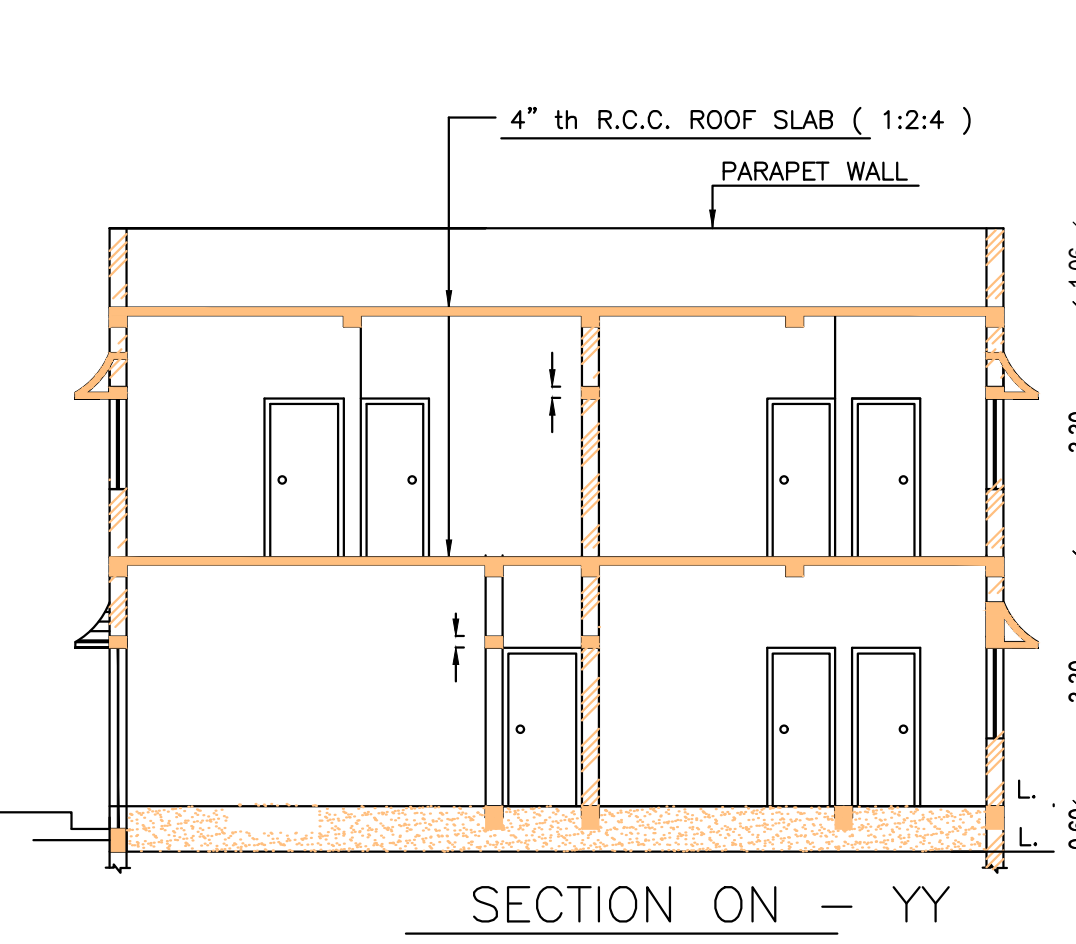

SECTION ON - YY

SCHEDULE OF DOOR:

BUILDING NAME	NAME	LENGTH	HEIGHT	NOS
A (SMT KUMARI SHIVANI)	D2	0.76	2.13	10
A (SMT KUMARI SHIVANI)	D1	0.90	2.13	07
A (SMT KUMARI SHIVANI)	D	1.05	2.13	04

SCHEDULE OF WINDOW/VENTILATION:

BUILDING NAME	NAME	LENGTH	HEIGHT	NOS
A (SMT KUMARI SHIVANI)	V	0.76	0.76	03
A (SMT KUMARI SHIVANI)	W3	0.90	1.52	03
A (SMT KUMARI SHIVANI)	G	0.90	1.52	01
A (SMT KUMARI SHIVANI)	W2	1.20	1.52	07
A (SMT KUMARI SHIVANI)	W1	1.62	1.52	02
A (SMT KUMARI SHIVANI)	W	1.80	1.52	10

Building :A (SMT KUMARI SHIVANI)

Floor Name	Total Built Up Area (Sq.mt.)	Proposed FAR Area (Sq.mt.) Resi.	Total FAR Area (Sq.mt.)	Total Consumed Additional FAR Area (Sq.mt.)	Tnmt (No.)
Ground Floor	158.84	158.84	158.84	158.84	01
First Floor	161.83	161.83	161.83	161.83	00
Terrace Floor	0.00	0.00	0.00	0.00	00
Total :	320.67	320.67	320.67	320.67	01
Total Number of Same Buildings :	1				
Total :	320.67	320.67	320.67	320.67	01

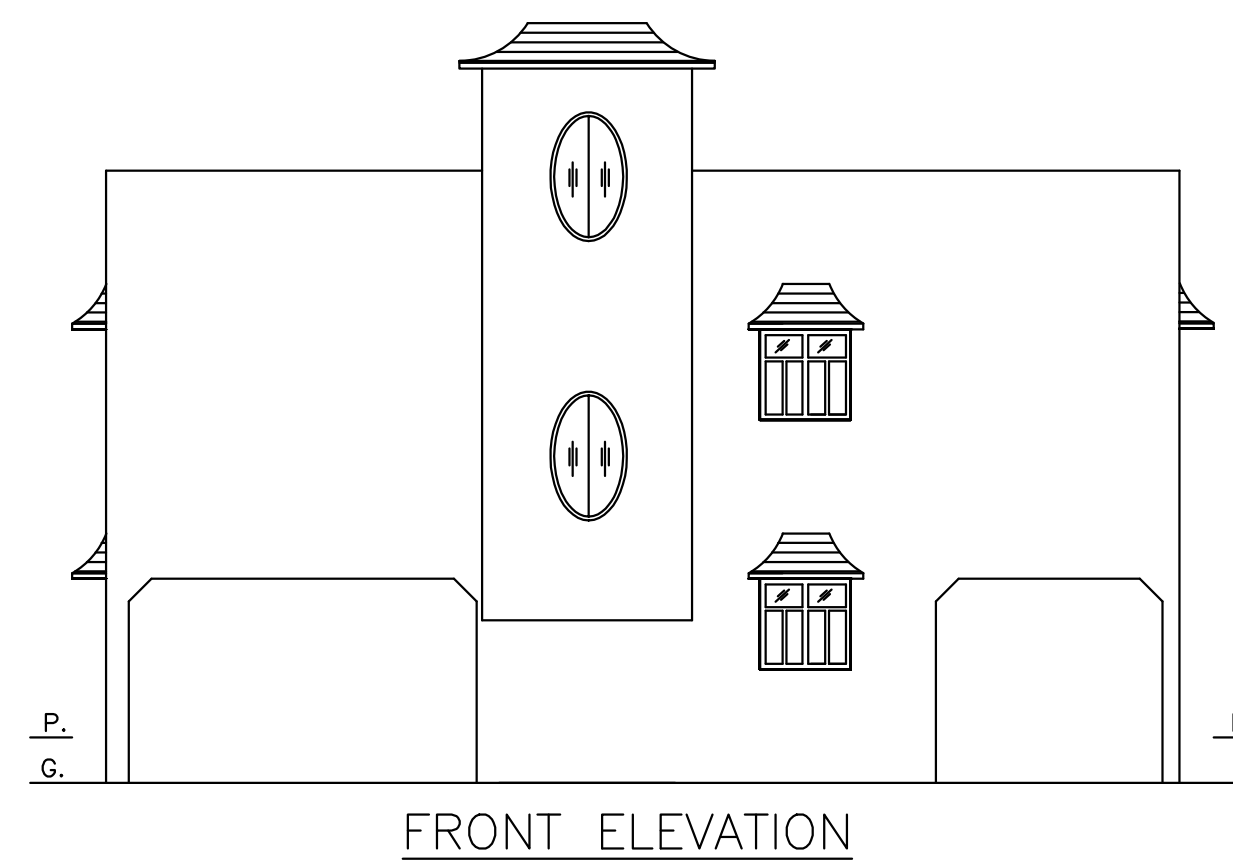

FRONT ELEVATION



SITE PLAN

LTP NAME AND SIGNATURE AMARENDRA KUMAR DMC/ENG/0009/2016	STRUCTURAL ENG'S NAME AND SIGNATURE	BUILDER NAME AND SIGNATURE
--	-------------------------------------	----------------------------



RIGHT SIDE ELEVATION

LTP NAME AND SIGNATURE	STRUCTURAL ENG'S NAME AND SIGNATURE	BUILDER NAME AND SIGNATURE
AMARENDRA KUMAR DMC/ENG/0009/2016		