

UnitBUA Table for Building :A (A)

FLOOR	Name	UnitBUA Type	UnitBUA Area	Carpet Area	No. of Rooms	No. of Tenement
GROUND FLOOR PLAN	SPLIT 1	FLAT	197.65	197.53	9	1
FIRST FLOOR PLAN	SPLIT 1	FLAT	0.00	0.00	9	0
Total:	-	-	197.65			1

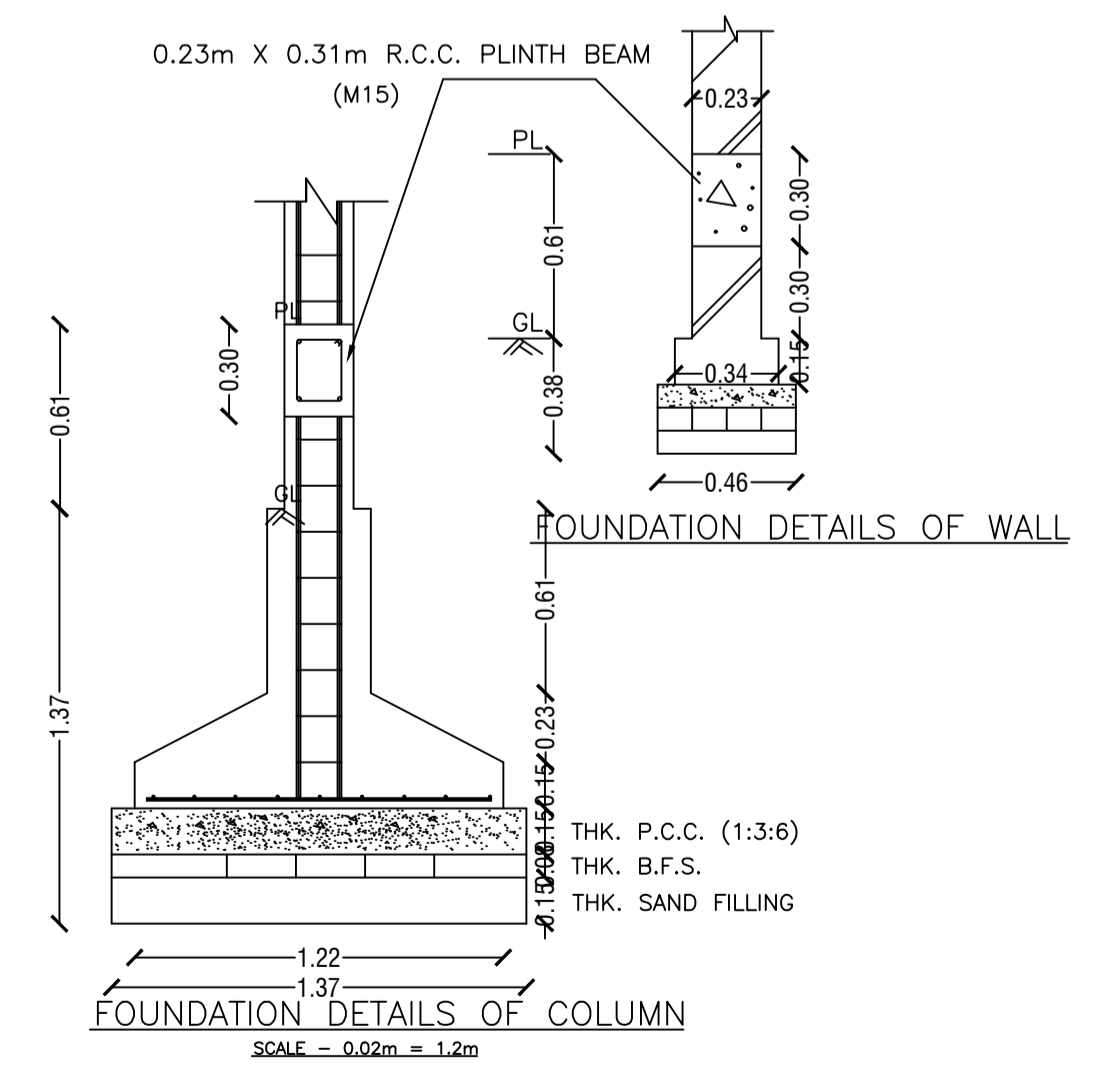
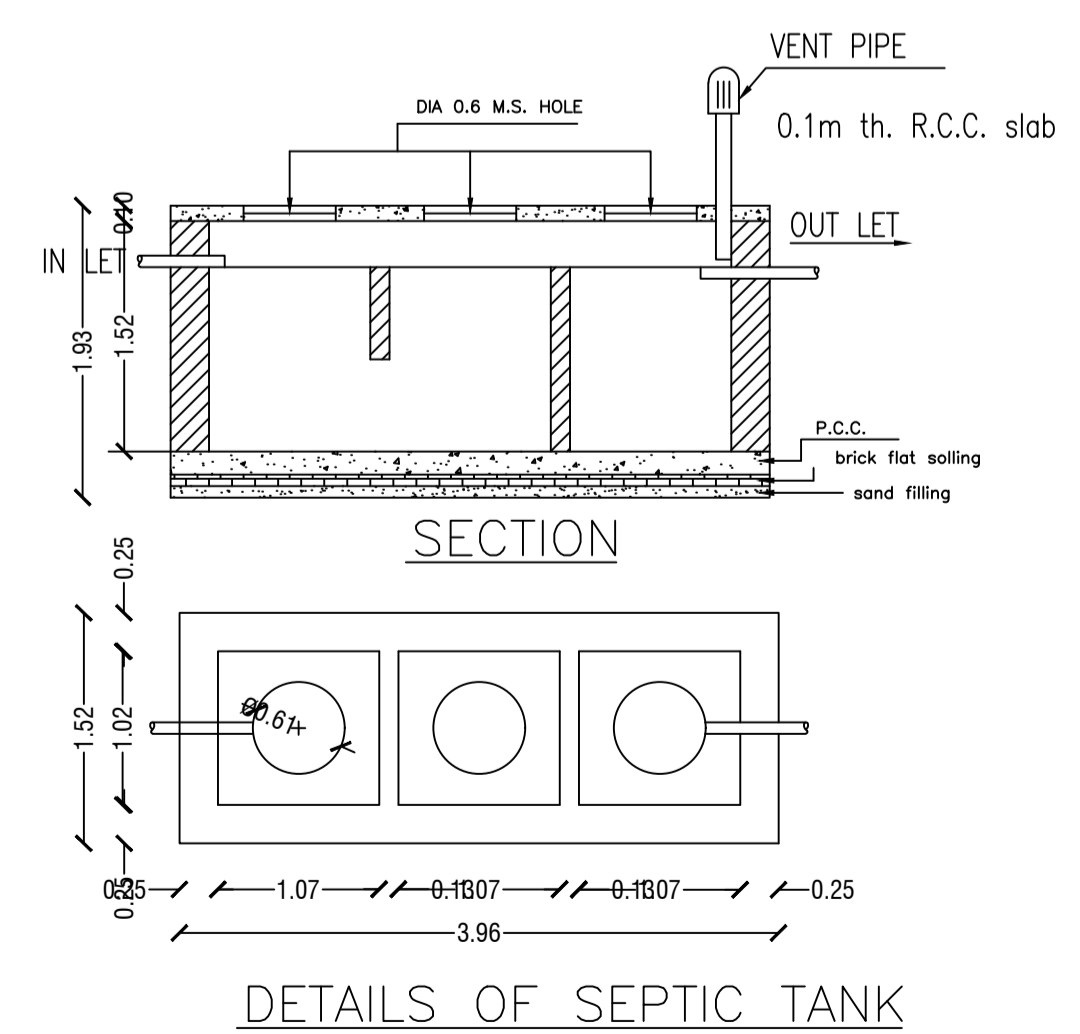
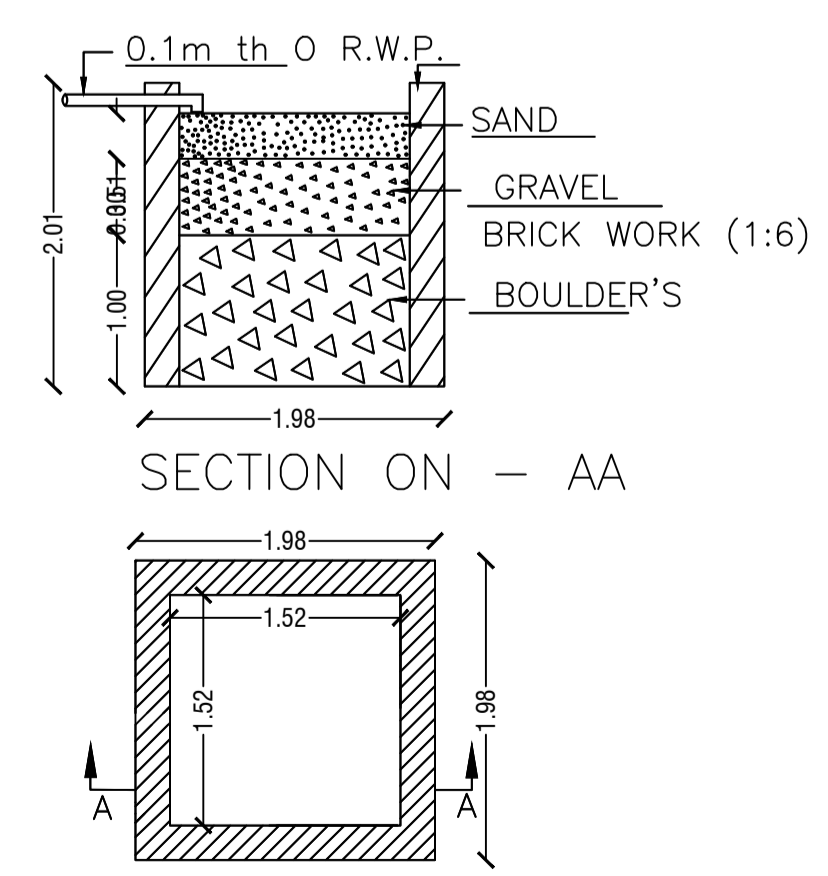

SCHEDULE OF DOOR:

BUILDING NAME	NAME	LENGTH	HEIGHT	NOS
A (A)	d	1.00	2.10	20

SCHEDULE OF WINDOW/VENTILATION:

BUILDING NAME	NAME	LENGTH	HEIGHT	NOS
A (A)	w	1.20	1.20	35

AREA STATEMENT		VERSION NO. : 1.0.24
DHANBAD MUNICIPAL CORPORATION		VERSION DATE: 30/03/2018
PROJECT DETAIL:		
Region: JHARKHAND URBAN	Plot Use: Residential	
LOCAL BODIES	Plot SubUse: Boarding	
District: DHANBAD	Plot/ReligiousStructure: NA	
Authority: DHANBAD MUNICIPAL CORPORATION	Plot/ReligiousStructure: NA	
Inward No: DMC/BP/0097/W/16/2017	Plot/SubPlot No: 70	
Application Type: General Proposal	North: Plot No. - 70	
Project Type: Building Permission	South: Plot No. - 70	
Nature of Development: New	East: Road Width - 4.26	
Location of Development Area: Old Area	West: Plot No. - RITA DEVI	
AREA DETAILS:		
AREA OF PLOT (Minimum)	(A)	163.39 SQ.MT.
Deduction for NetPlot Area		
Surrender Free of Cost		4.06
Total		4.06
NET AREA OF PLOT(Gross Plot Area - Deduction from Gross Plot area)	(A-Deductions)	159.33
Deduction for Balance Plot Area(from Gross Plot Area)		
Surrender Free of Cost		4.06
Common Plot		23.30
Total		27.36
BALANCE AREA OF PLOT(Net Plot Area - Recreational/Amenity space)	(A-Deductions)	136.03
PLOT AREA FOR COVERAGE(Net Plot Area)	(A-Deductions)	159.33
Plot Area for FAR (Net Plot Area + RoadWidening Area)	(A-Deductions)	163.39
COVERAGE CHECK		
Permissible Coverage area (70.00 %)		111.53
Proposed Coverage Area (62.02 %)		98.82
Total Prop. Coverage Area (62.02 %)		98.82
Balance coverage area (7.98 %)		12.71
FAR CHECK		
Perm. FAR Area (2.50)		408.48
Total Perm. FAR area		408.48
Residential FAR		197.65
Proposed FAR Area		197.65
Total Proposed FAR Area		197.65
Consumed FAR (Factor)		1.21
Balance FAR Area		210.83
BUILT UP AREA CHECK		
Total Proposed BuiltUp Area		197.64
ARCHITECT (Regd)		NISHANT KUMAR
ENGINEER (Regd)		
SUPERVISOR (Regd)		
OWNER (Regd)		SMT ASHA DEVI
DEVELOPMENT AUTHORITY		LOCAL BODY

COLOR INDEX

PLOT BOUNDARY	Black
ABUTTING ROAD	Green
PROPOSED CONSTRUCTION	Red
COMMON PLOT	Yellow
ROAD WIDENING AREA	Blue
EXISTING (To be retained)	Grey
EXISTING (To be demolished)	White

Buildingwise Floor FAR Details

Floor Name	Building Name		Total	
	Proposed Built Up Area (Sq.mt.)	Proposed FAR Area (Sq.mt.)	Total Proposed Built Up Area (Sq.mt.)	Total FAR Area (Sq.mt.)
Ground Floor	98.82	98.82	98.82	98.82
First Floor	98.82	98.82	98.82	98.82
Terrace Floor	0.00	0.00	0.00	0.00
Total :	197.64	197.64	197.64	197.64

Building USE/SUBUSE Details

Building Name	Building Use	Building SubUse	Building Structure
A (A)	Residential	Residential Bldg/Apartment	Non-Highrise

FAR & Tenement Details (Table 4c-1)

Building	No. of Same Bldg	Total Built Up Area (Sq.mt.)	Proposed FAR Area (Sq.mt.) Resi.	Total FAR Area (Sq.mt.)	Total Consumed Additional FAR Area (Sq.mt.)	Tnmt (No.)
A (A)	1	197.64	197.64	197.64	197.64	01
Grand Total :	1	197.64	197.64	197.64	197.64	01

Building :A (A)

Floor Name	Total Built Up Area (Sq.mt.)	Proposed FAR Area (Sq.mt.) Resi.	Total FAR Area (Sq.mt.)	Total Consumed Additional FAR Area (Sq.mt.)	Tnmt (No.)
First Floor	98.82	98.82	98.82	98.82	01
Terrace Floor	98.82	98.82	98.82	98.82	00
Total :	197.64	0.00	0.00	0.00	00
Total Number of Same Buildings :	1				01
Total :	197.64	197.64	197.64	197.64	01

LTP NAME AND SIGNATURE	STRUCTURAL ENG'S NAME AND SIGNATURE	BUILDER NAME AND SIGNATURE
NISHANT KUMAR DMC/ENG/0006/2016		

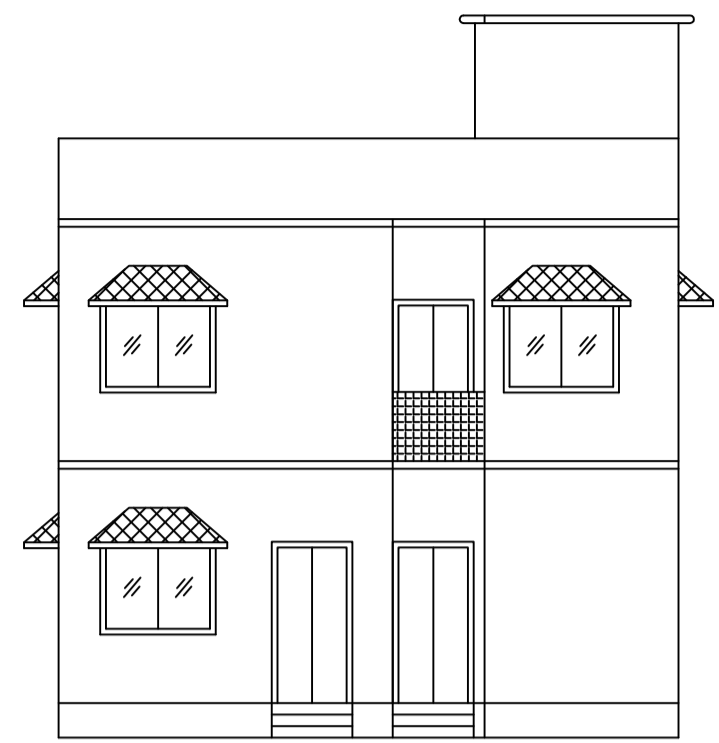

FRONT ELEVATION

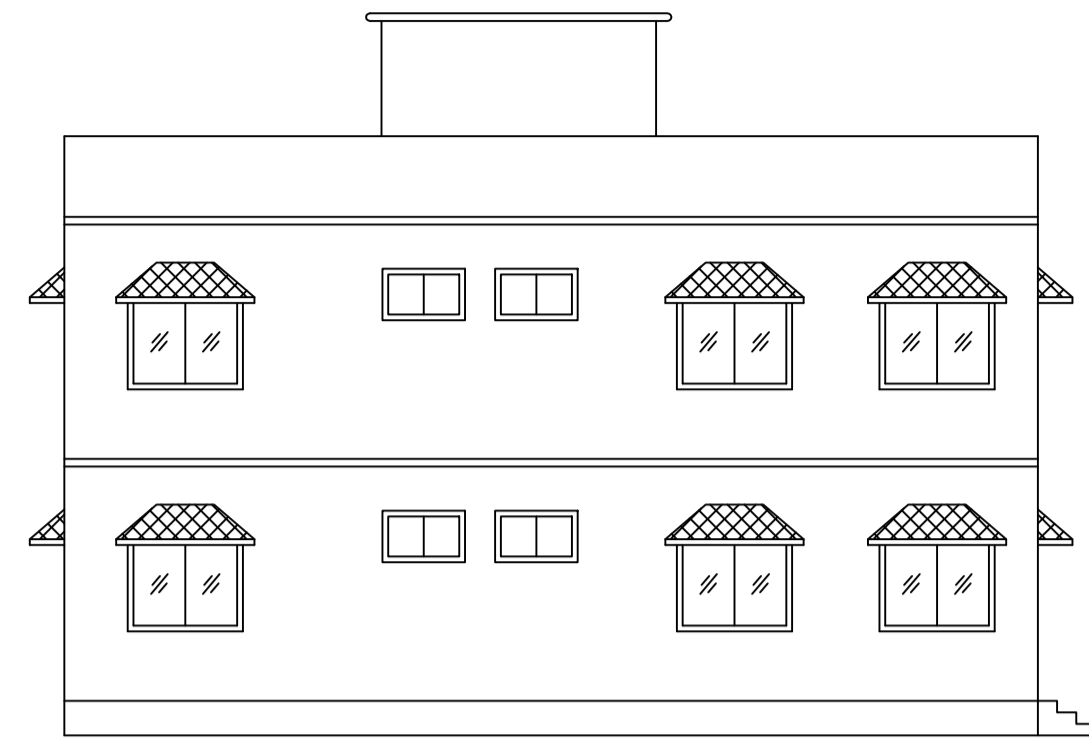

LEFT SIDE ELEVATION

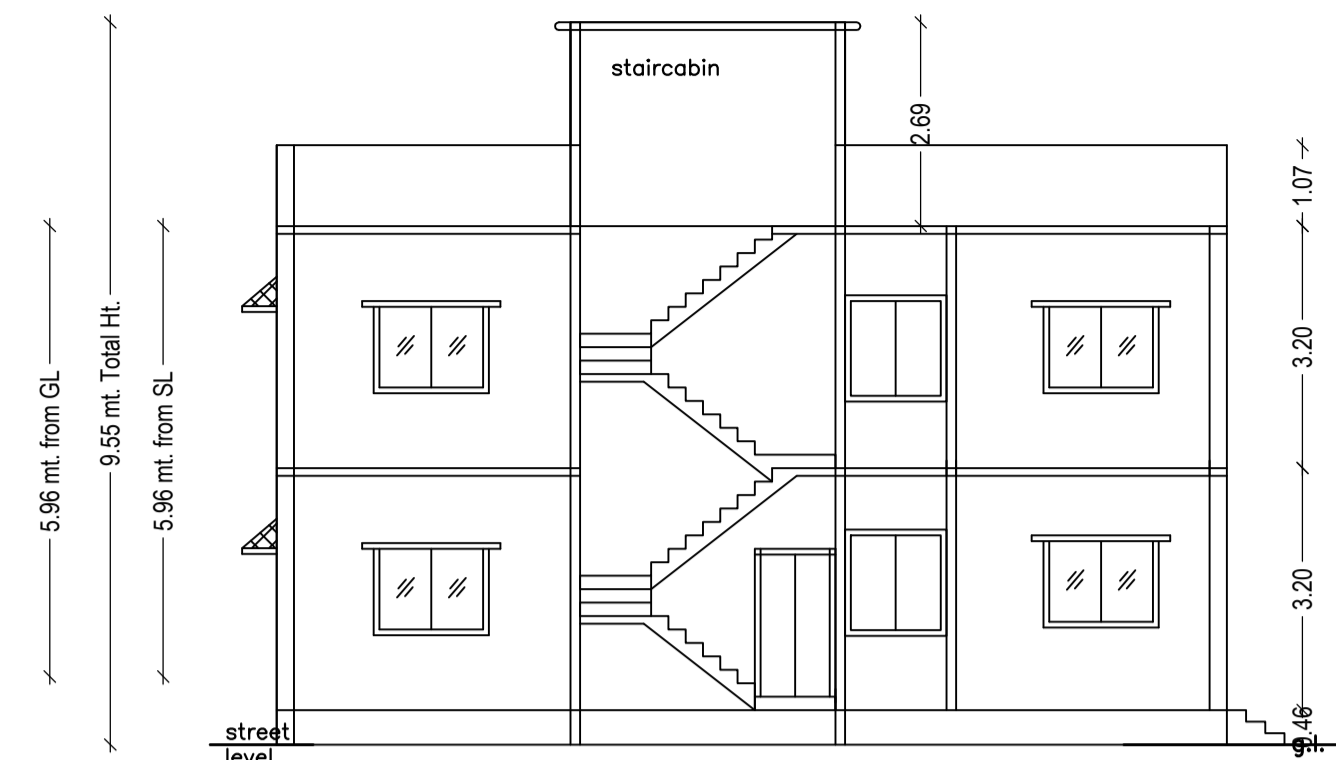

SECTION AT X-X

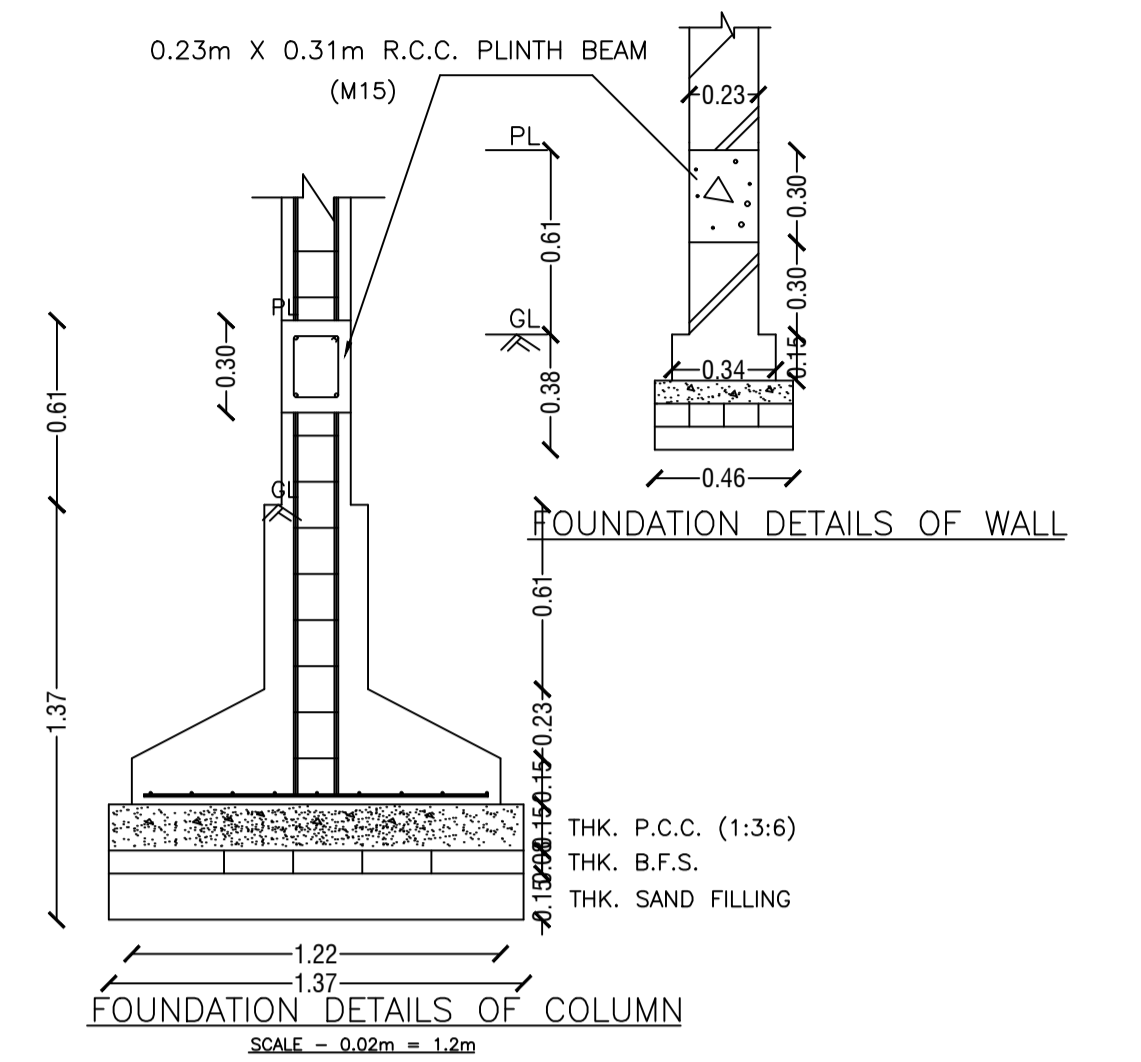

FOUNDATION DETAILS OF WALL
FOUNDATION DETAILS OF COLUMN
SCALE - 0.02m = 1.2m

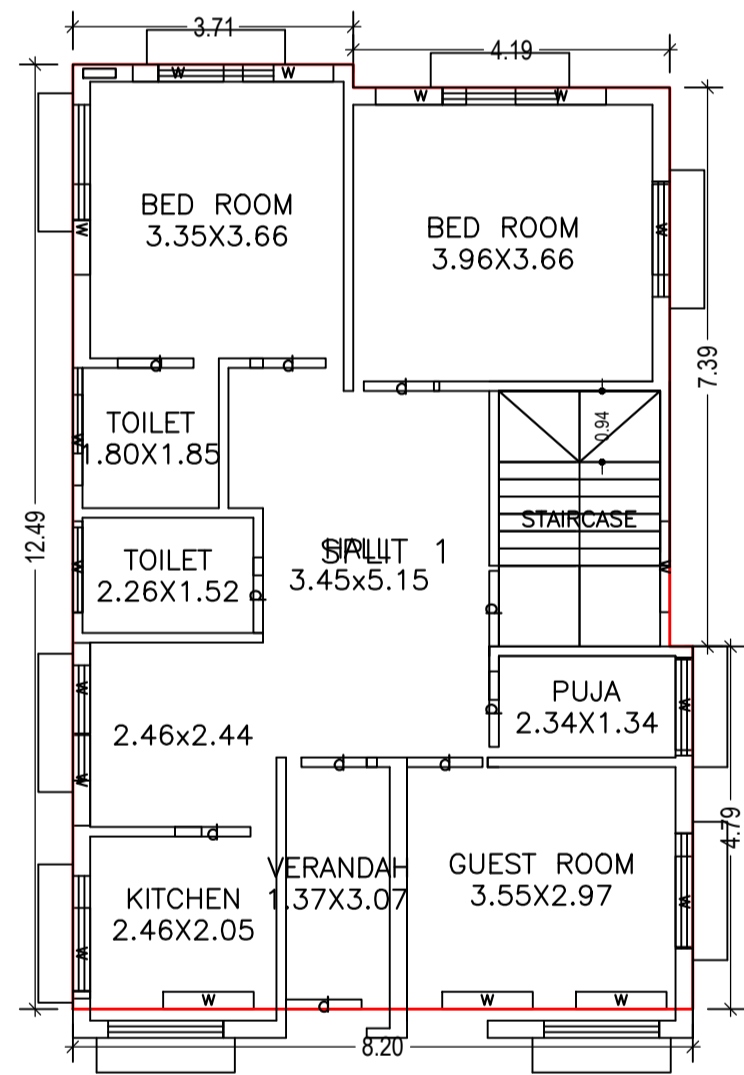

GROUND FLOOR PLAN
(Proposed)
(SCALE 1:100)

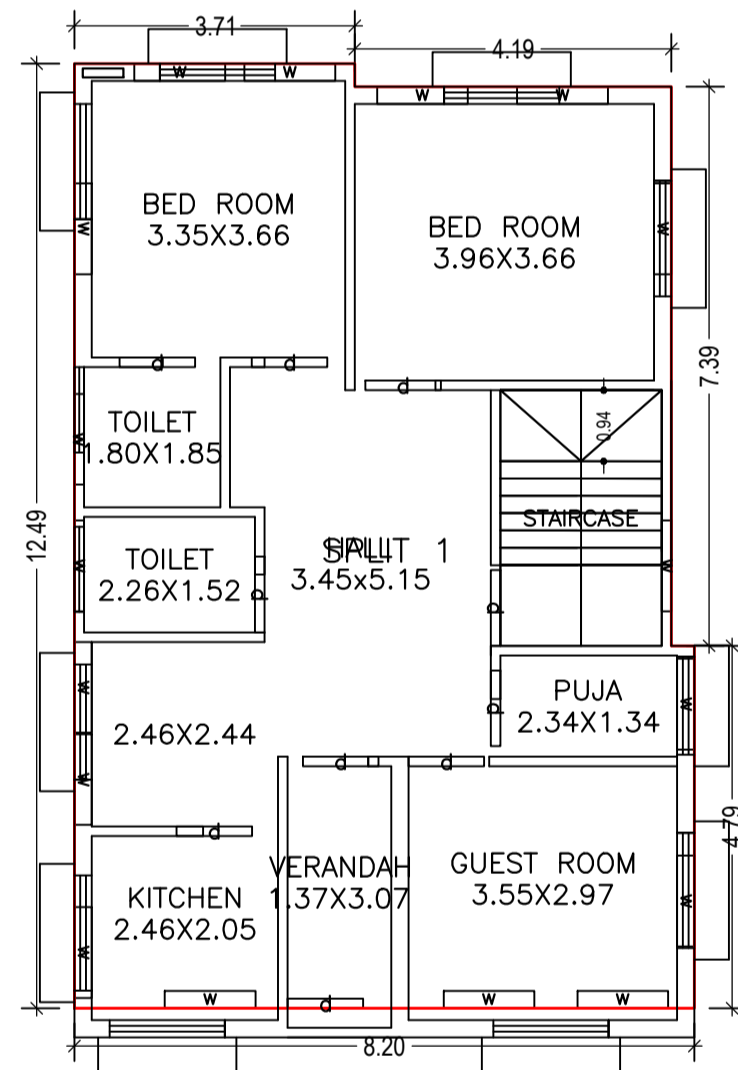

FIRST FLOOR PLAN
(Proposed)
(SCALE 1:100)

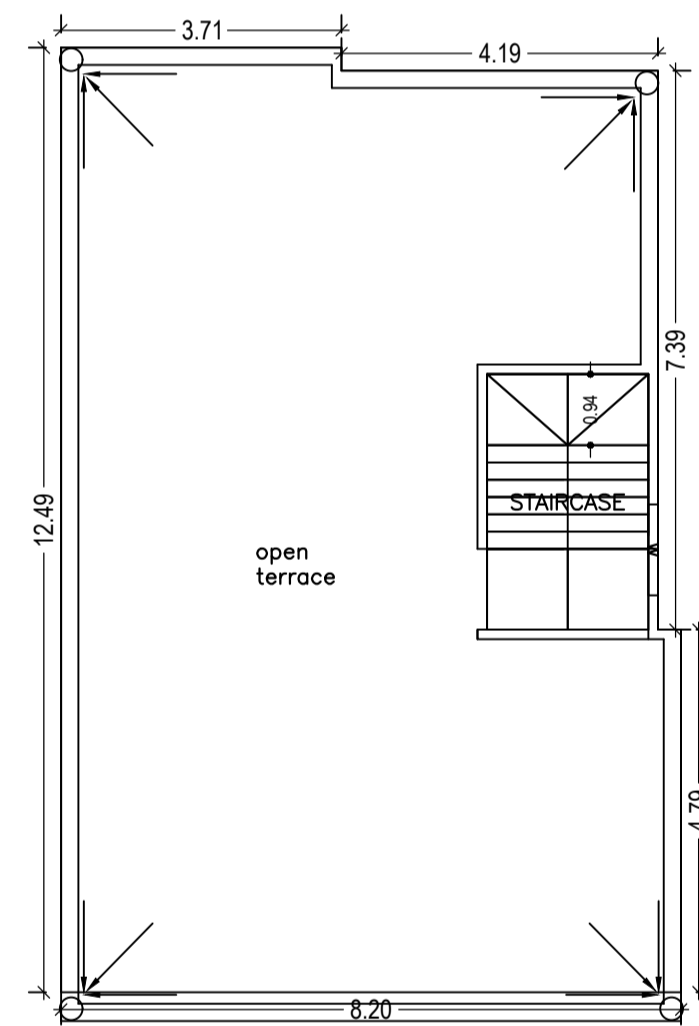

TERRACE FLOOR PLAN
(SCALE 1:100)

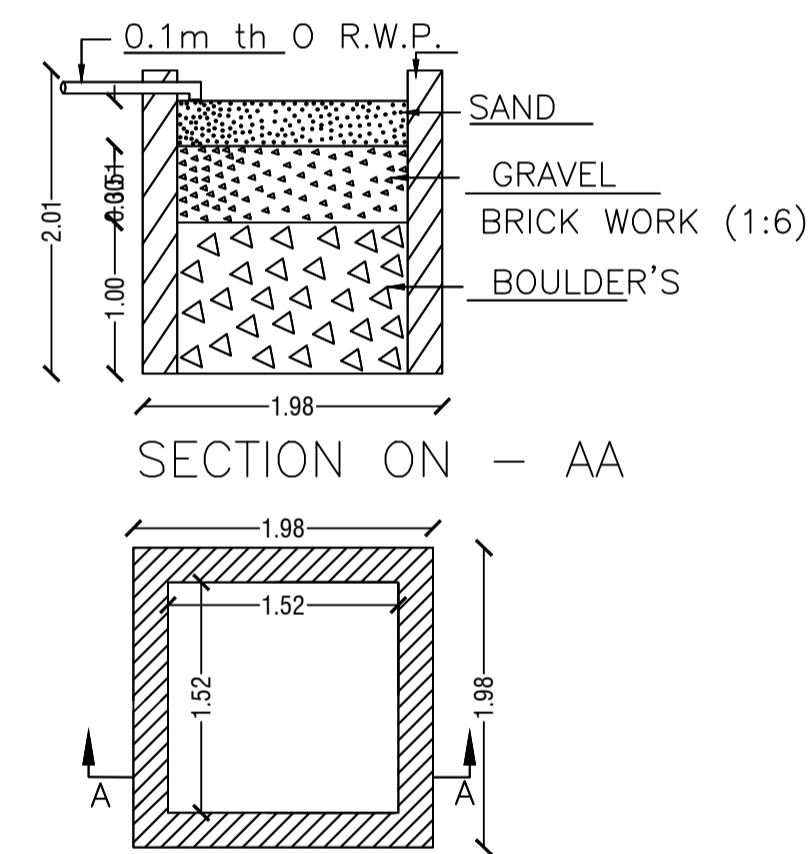

SECTION ON - AA

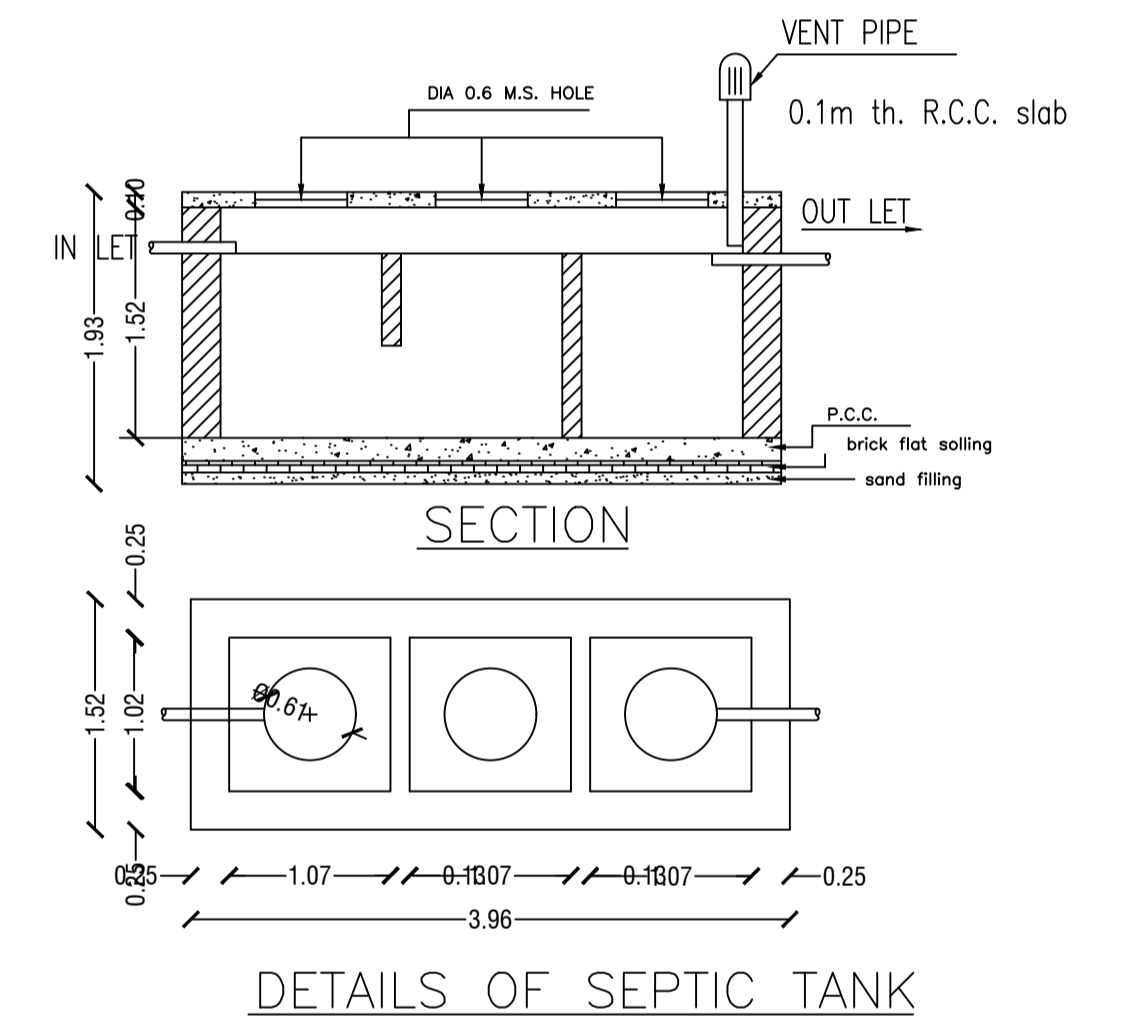

DETAILS OF SEPTIC TANK

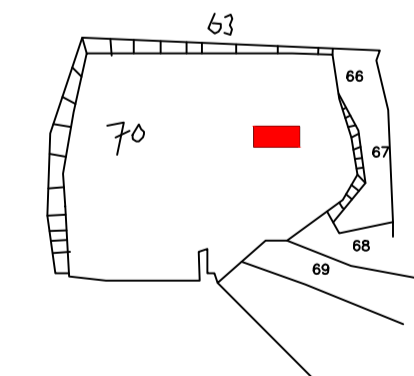

LTP NAME AND SIGNATURE	STRUCTURAL ENG'S NAME AND SIGNATURE	BUILDER NAME AND SIGNATURE
NISHANT KUMAR DMC/ENG/0006/2016		