

SITE PLAN
SITE PLAN

FAR & Tenement Details (Table 4c-1)

Building	No. of Same Bldg	Total Built Up Area (Sq.mt.)	Proposed FAR Area (Sq.mt.) Res.	Total FAR Area (Sq.mt.)	Total Consumed Additional FAR Area (Sq.mt.)	Tnmt (No.)
A (RESIDENTIAL)	1	319.10	319.10	319.10	319.10	01
Grand Total :	1	319.10	319.10	319.10	319.10	01

Building :A (RESIDENTIAL)

Floor Name	Total Built Up Area (Sq.mt.)	Proposed FAR Area (Sq.mt.) Res.	Total FAR Area (Sq.mt.)	Total Consumed Additional FAR Area (Sq.mt.)	Tnmt (No.)
Ground Floor	159.55	159.55	159.55	159.55	01
First Floor	159.55	159.55	159.55	159.55	00
Terrace Floor	0.00	0.00	0.00	0.00	00
Total :	319.10	319.10	319.10	319.10	01
Total Number of Same Buildings :	1				
Total :	319.10	319.10	319.10	319.10	01

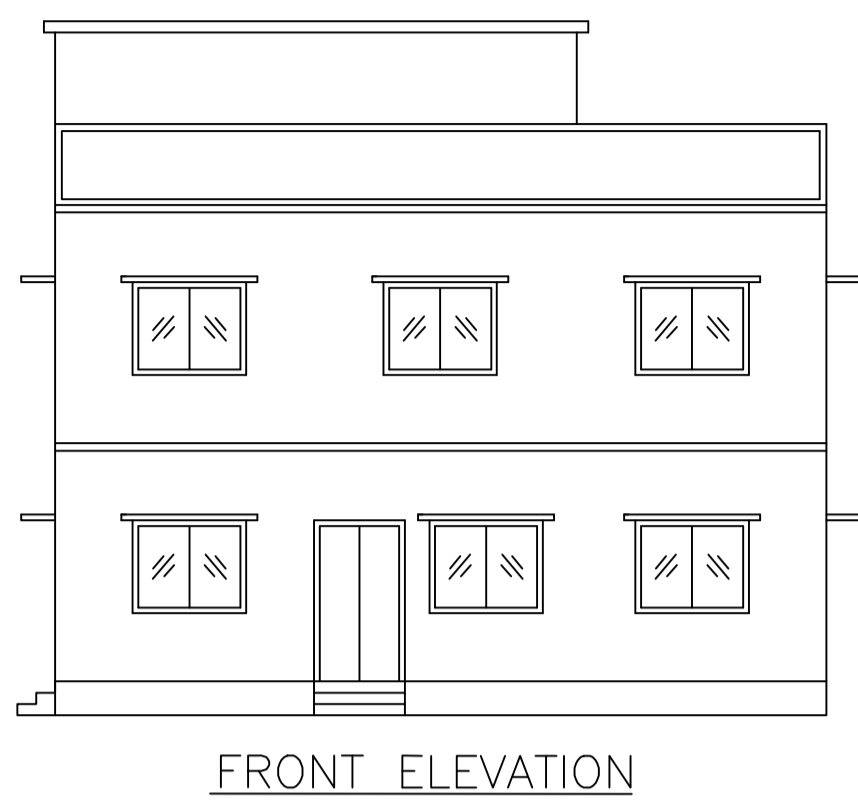

FRONT ELEVATION

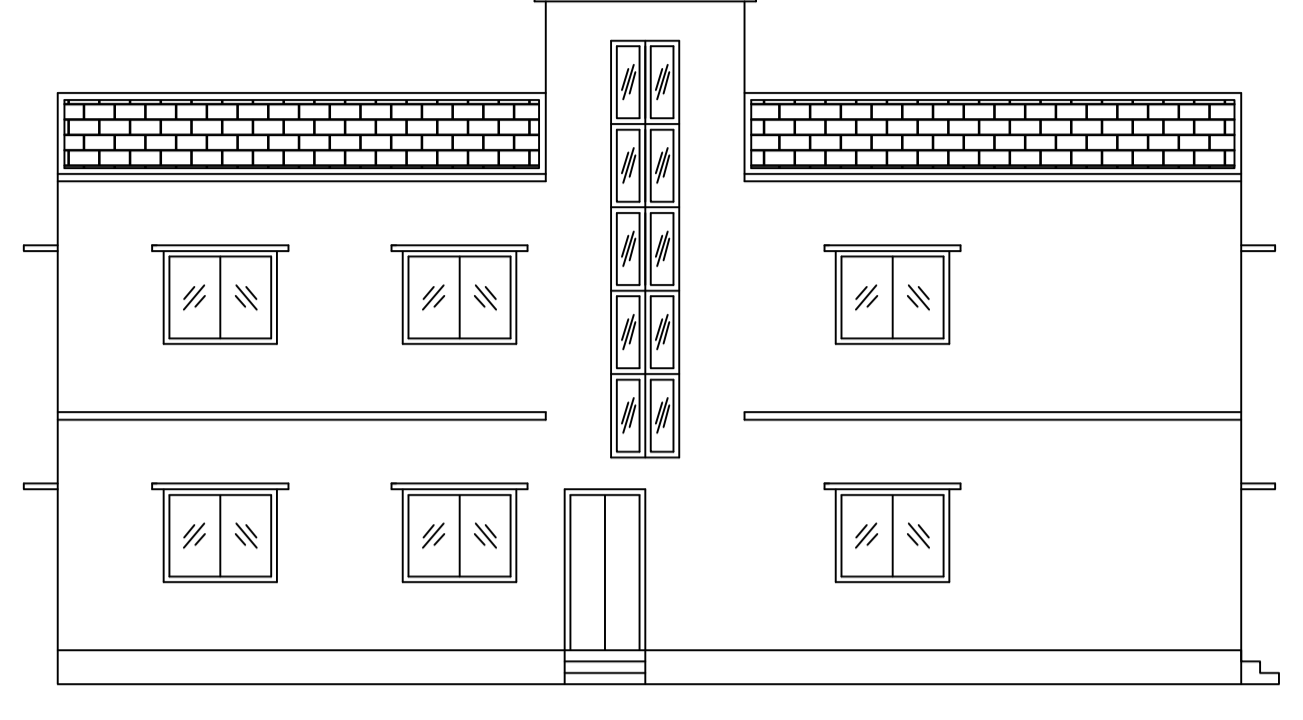

LEFT SIDE ELEVATION

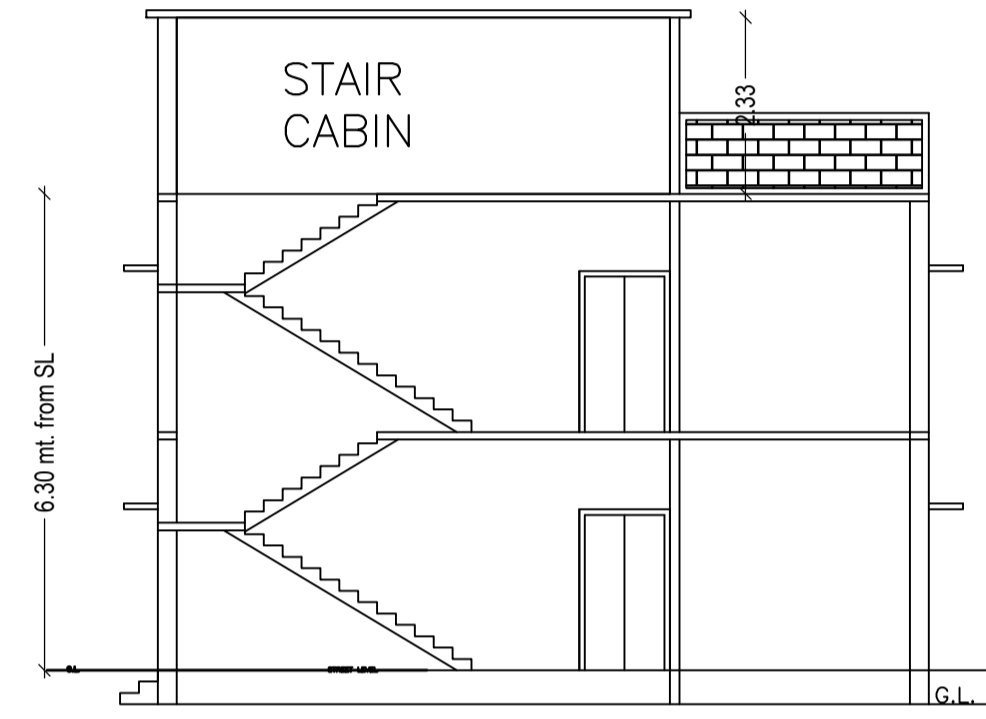

SECTION ON X-X

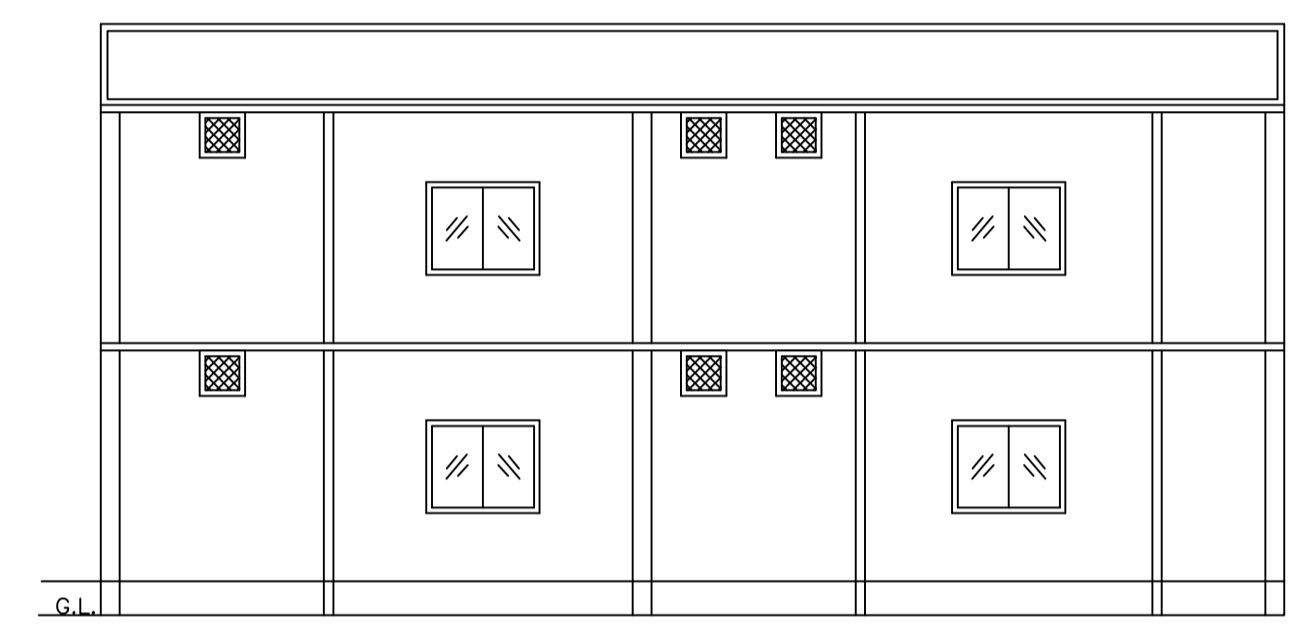

SECTION ON Y-Y

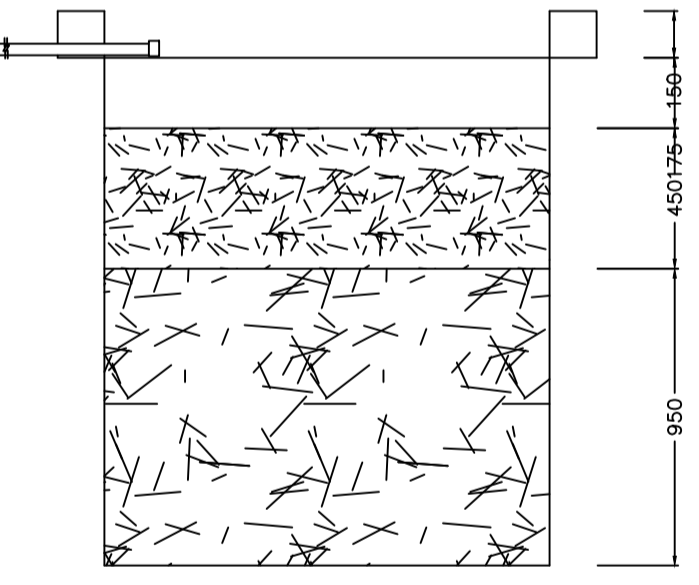

SECTION AT Y-Y

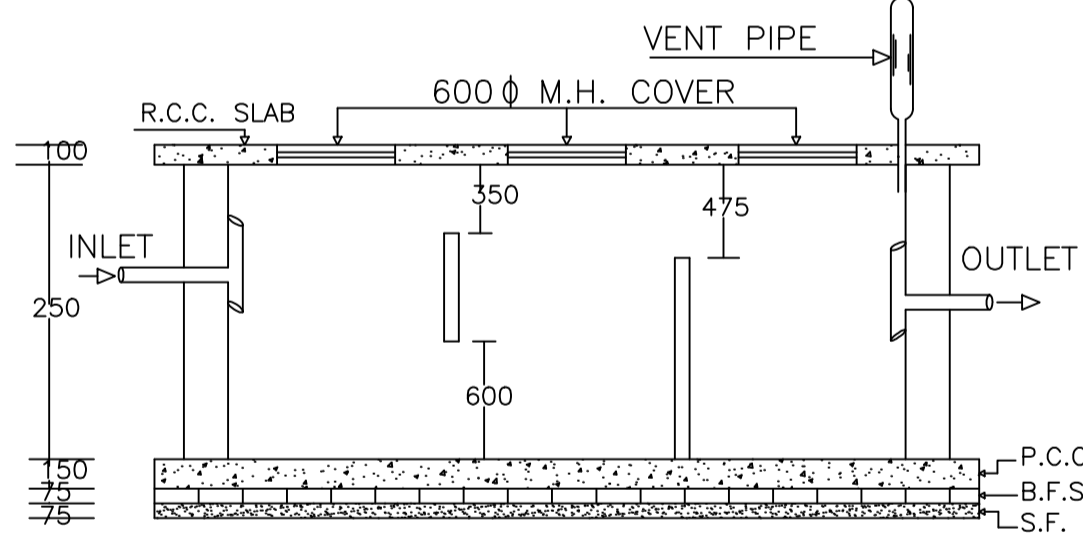

PLAN OF SEPTIC TANK

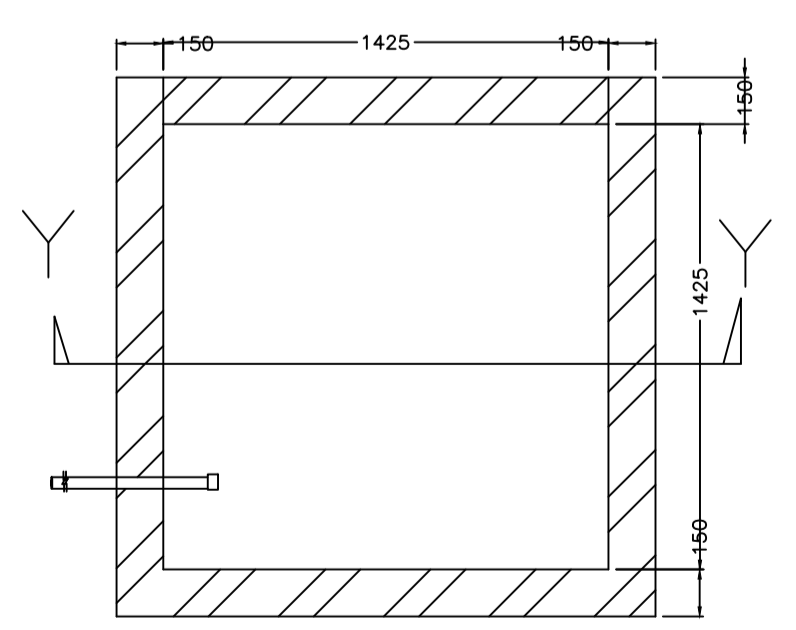

PLAN OF RECHARGE WELL

WATER HARVESTING

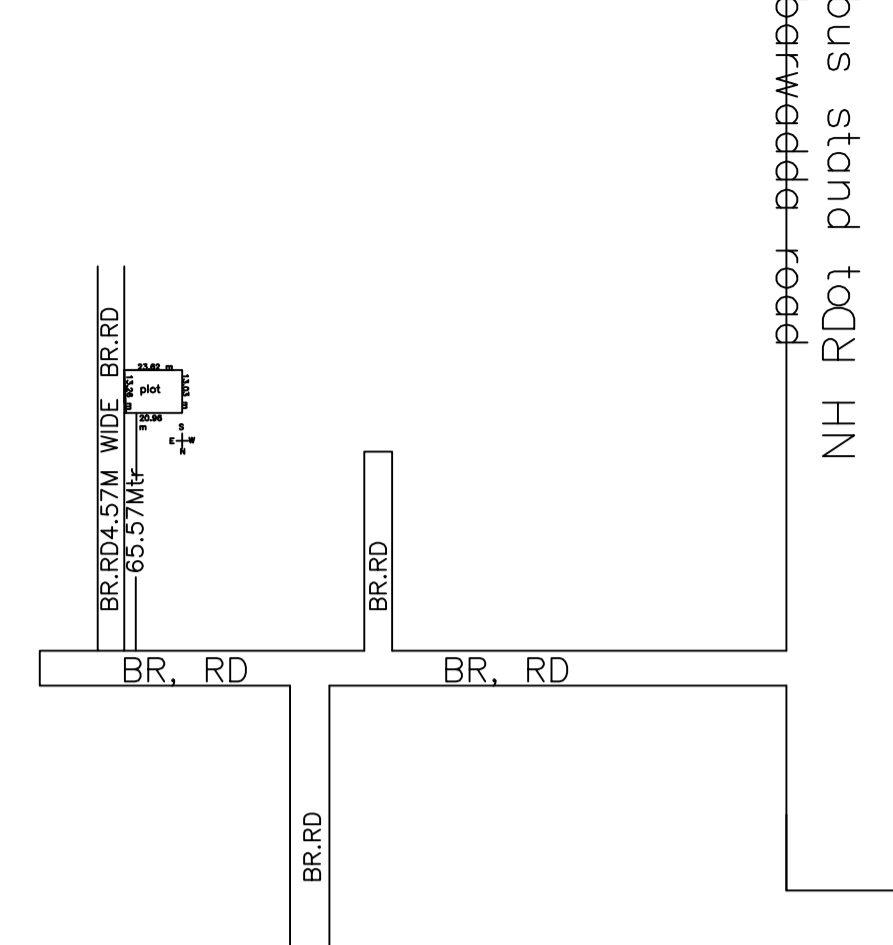

LOCATION PLAN

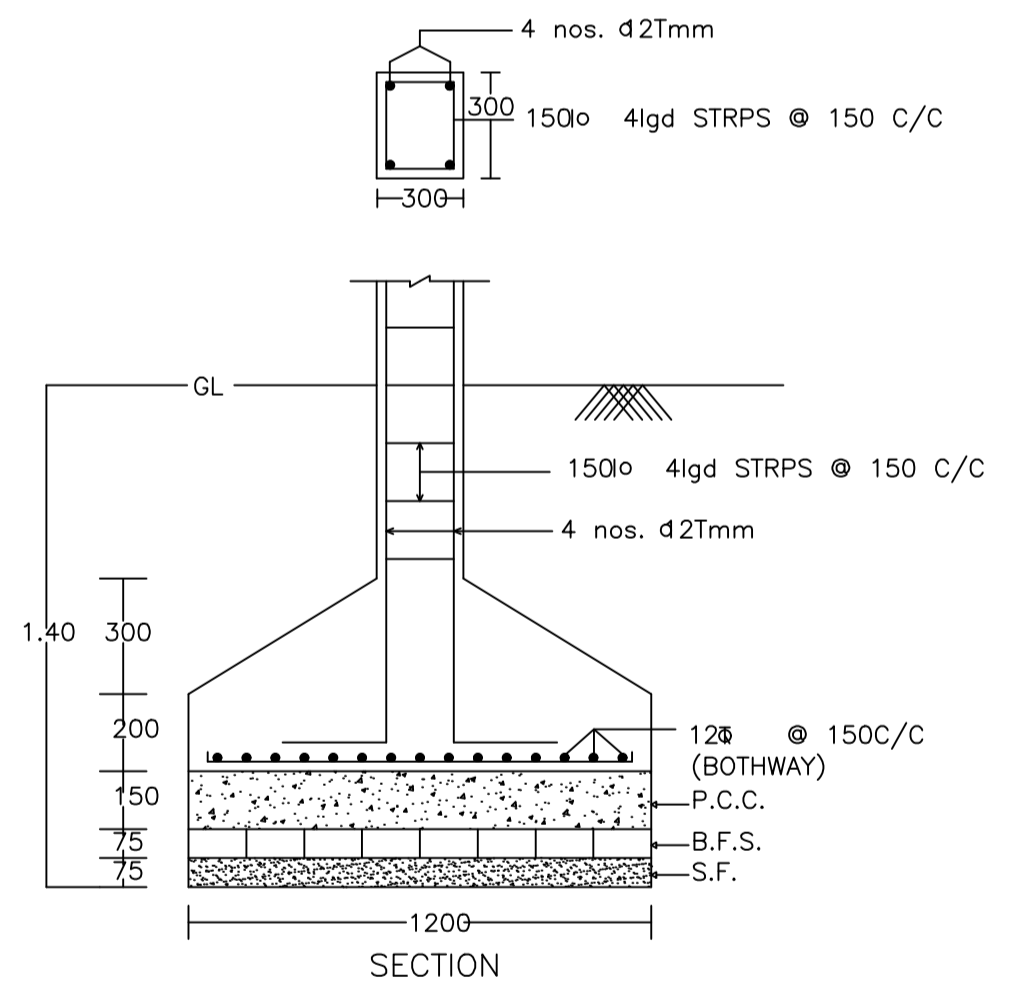

SECTION

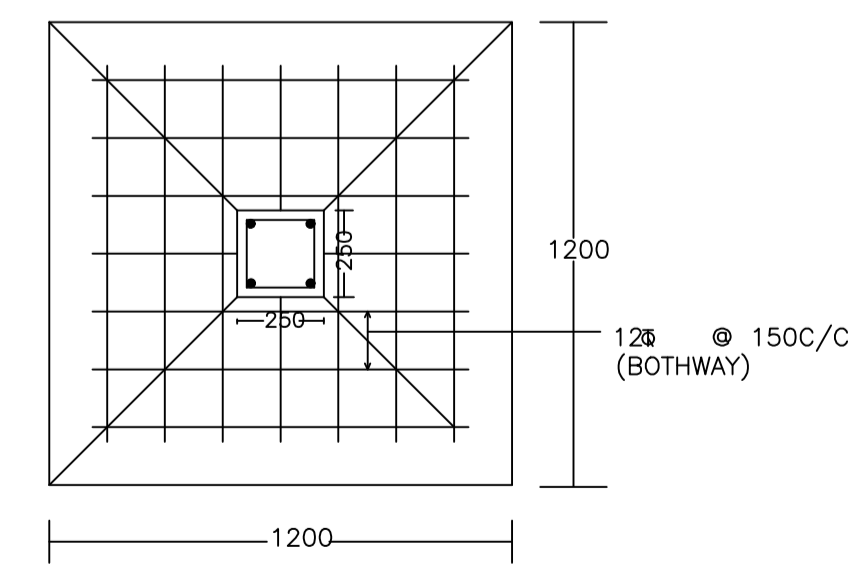

PLAN

DETAIL OF COLUMNS

AREA STATEMENT		VERSION NO. : 1.0.25
DHANBAD MUNICIPAL CORPORATION		VERSION DATE: 12/04/2018
PROJECT DETAIL:		
Region: JHARKHAND URBAN	Plot Use: Residential	
LOCAL BODIES	Plot SubUse: Bungalow/ Dwelling / Non Apartment	
District: DHANBAD	Plot/Nearby/Religious/Structure: NA	
Authority: DHANBAD MUNICIPAL CORPORATION	Plot/SubPlot No: 1737	
Inward No: DMC/BP/163/W22/2017	North: Plot No. - PART OF PLOT NO.1737	
Application Type: General Proposal	South: Plot No. - PART OF PLOT NO.1737	
Project Type: Building Permission	East: Road Width - 4.57	
Nature of Development: New	West: Plot No. - PART OF PLOT NO.1737	
Location of Development Area: Old Area		
AREA DETAILS:		
AREA OF PLOT (Minimum)	(A)	SQ.MT. 289.44
Deduction for NetPlot Area		11.97
Surrender Free of Cost		11.97
NET AREA OF PLOT(Gross Plot Area - Deduction from Gross Plot area)	(A-Deductions)	277.48
Deduction for Balance Plot Area(from Gross Plot Area)		11.97
Surrender Free of Cost		38.06
Common Plot		50.03
BALANCE AREA OF PLOT(Net Plot Area - Recreational/Amenity space)	(A-Deductions)	239.41
PLOT AREA FOR COVERAGE(Net Plot Area)	(A-Deductions)	277.48
Plot Area for FAR (Net Plot Area + Road/Widening Area)	(A-Deductions)	289.44
COVERAGE CHECK		
Permissible Coverage area (60.00 %)		166.49
Proposed Coverage Area (57.50 %)		159.55
Total Prop. Coverage Area (57.5 %)		159.55
Balance coverage area (2.50 %)		6.94
FAR CHECK		
Perm. FAR Area (1.50)		434.16
Total Perm. FAR area		434.16
Residential FAR		319.10
Proposed FAR Area		319.10
Total Proposed FAR Area		319.10
Consumed FAR (Factor)		1.10
Balance FAR Area		115.06
BUILT UP AREA CHECK		
Total Proposed BuiltUp Area		319.10
ARCHITECT (Regd)		PARTHA - PAL
ENGINEER (Regd)		
SUPERVISOR (Regd)		
OWNER (Regd)		VINOD KUMAR SAW
DEVELOPMENT AUTHORITY		LOCAL BODY

COLOR INDEX	
PLOT BOUNDARY	Black
ABUTTING ROAD	Red
PROPOSED CONSTRUCTION	Green
COMMON PLOT	Yellow
ROAD WIDENING AREA	Blue
EXISTING (To be retained)	Orange
EXISTING (To be demolished)	Purple

Buildingwise Floor FAR Details

Floor Name	Building Name A (RESIDENTIAL)		Total	
	Proposed Built Up Area (Sq.mt.)	Proposed FAR Area (Sq.mt.)	Total Proposed Built Up Area (Sq.mt.)	Total FAR Area (Sq.mt.)
Ground Floor	159.55	159.55	159.55	159.55
First Floor	159.55	159.55	159.55	159.55
Terrace Floor	0.00	0.00	0.00	0.00
Total :	319.10	319.10	319.10	319.10

Building USE/SUBUSE Details

Building Name	Building Use	Building SubUse	Building Structure
A (RESIDENTIAL)	Residential	Residential Bldg/Apartment	Non-Highrise

SCHEDULE OF DOOR:

BUILDING NAME	NAME	LENGTH	HEIGHT	NOS
A (RESIDENTIAL)	D2	0.90	2.10	10
A (RESIDENTIAL)	D1	1.05	2.10	08
A (RESIDENTIAL)	D	1.20	2.10	05

SCHEDULE OF WINDOW/VENTILATION:

BUILDING NAME	NAME	LENGTH	HEIGHT	NOS
A (RESIDENTIAL)	V	0.60	0.60	06
A (RESIDENTIAL)	W1	1.50	1.20	16
A (RESIDENTIAL)	W1	1.80	1.20	02
A (RESIDENTIAL)	W1	1.96	1.20	02

UnitBUA Table for Building :A (RESIDENTIAL)

FLOOR	Name	UnitBUA Type	UnitBUA Area	Carpet Area	No. of Rooms	No. of Tenement
GROUND FLOOR PLAN	SPLIT SPLIT 1	FLAT	266.00	265.20	12	1
FIRST FLOOR PLAN	SPLIT SPLIT 1	FLAT	0.00	0.00	12	0
Total:	-	-	266.00	265.20	24	1

LTP NAME AND SIGNATURE	STRUCTURAL ENG'S NAME AND SIGNATURE	BUILDER NAME AND SIGNATURE
PARTHA - PAL DMC/ENG/0021/2016		

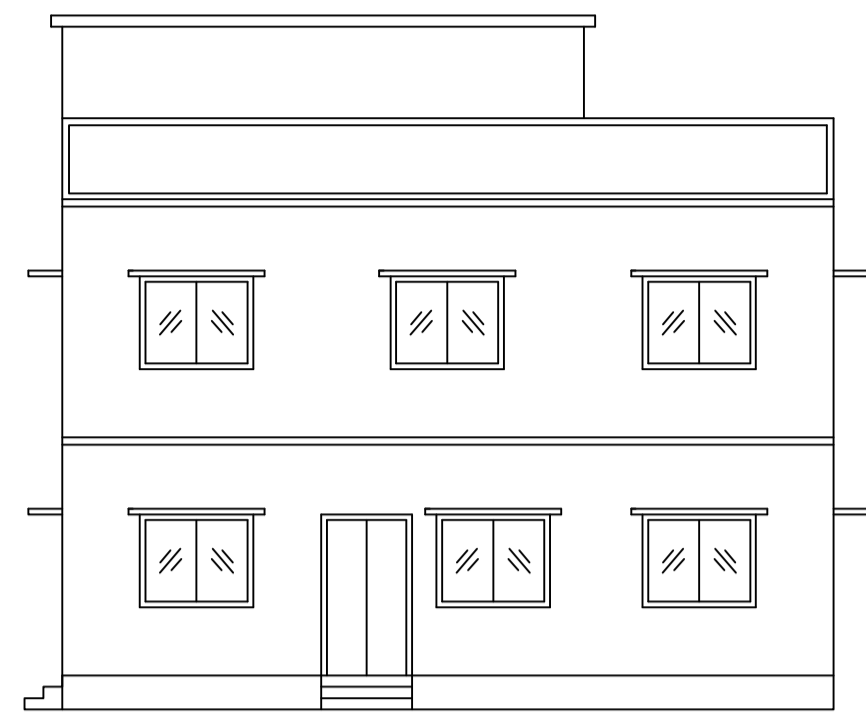

FRONT ELEVATION

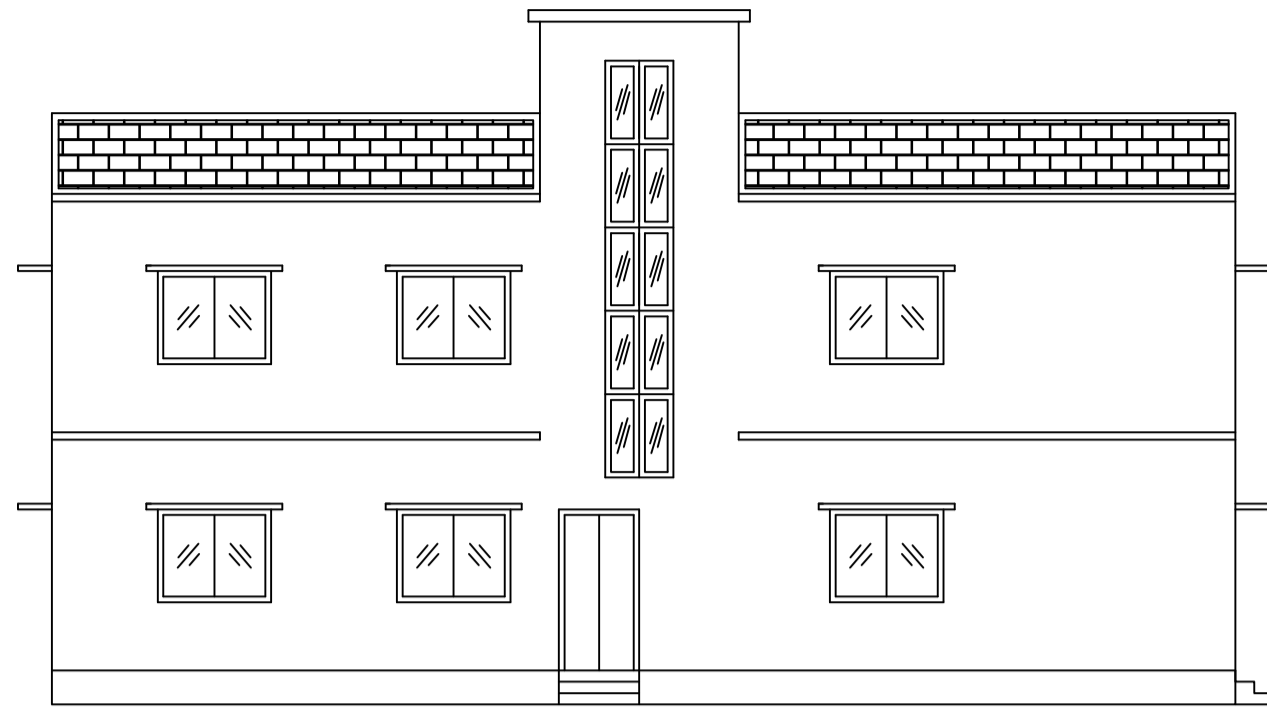

LEFT SIDE ELEVATION

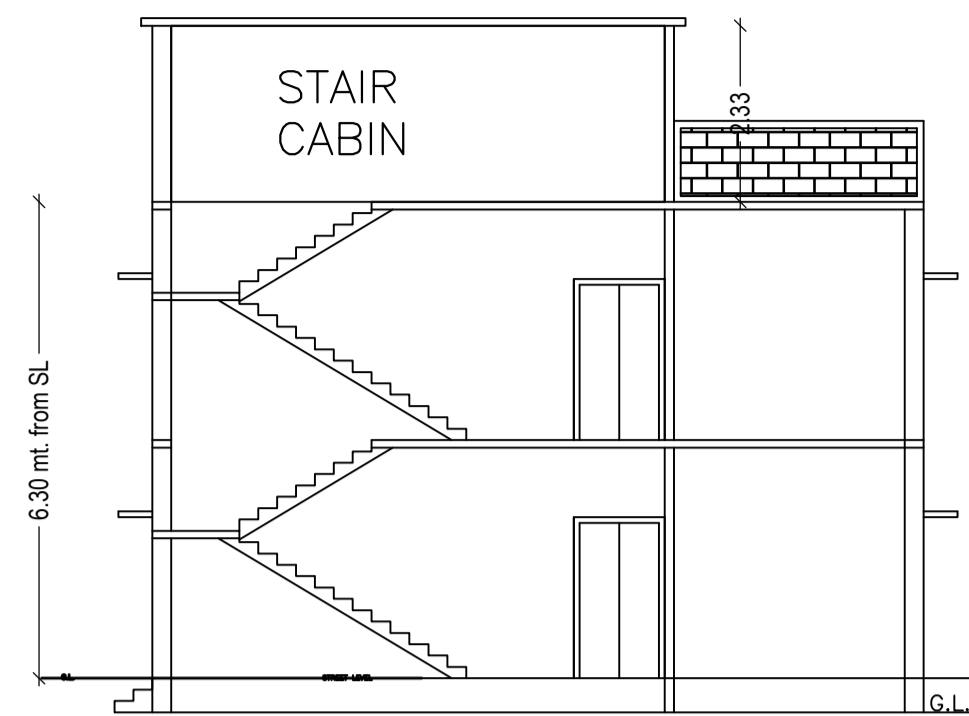

SECTION ON X-X

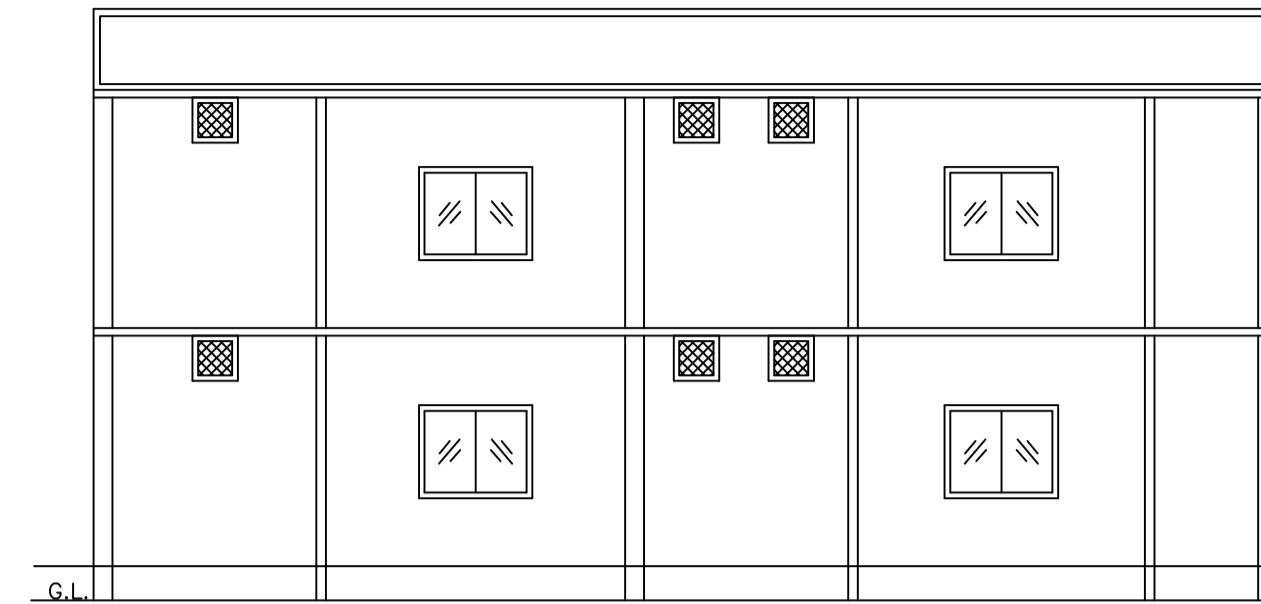

SECTION ON Y-Y

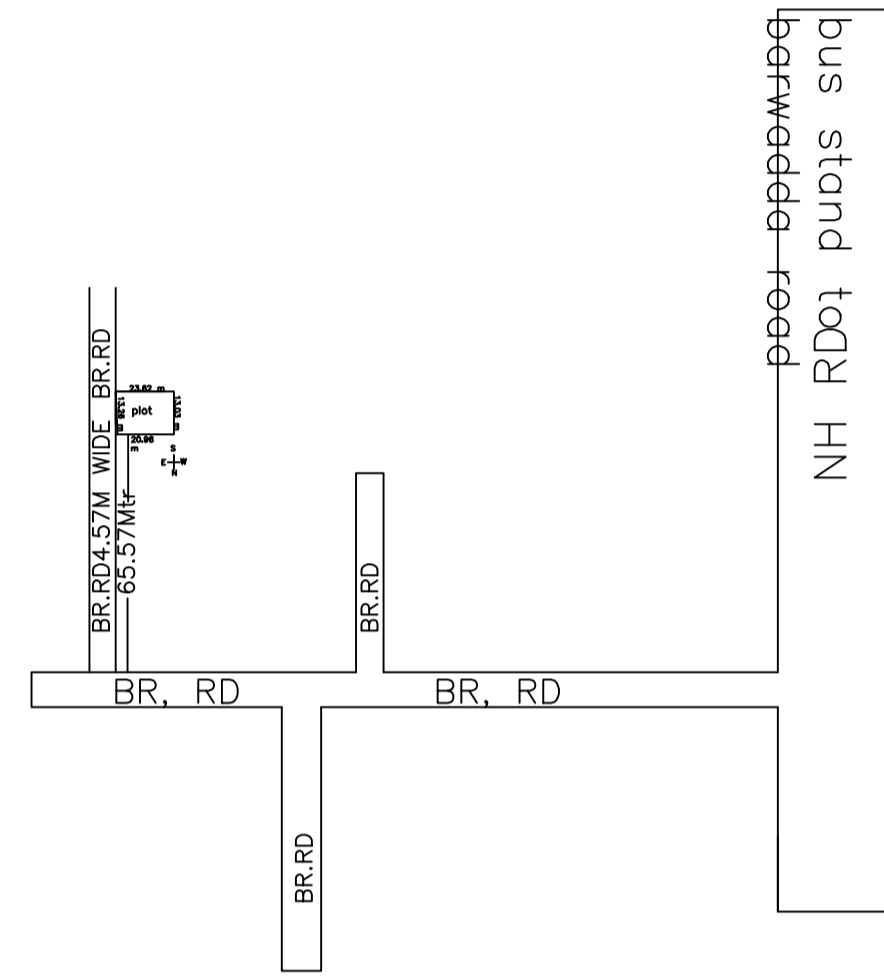

LOCATION PLAN

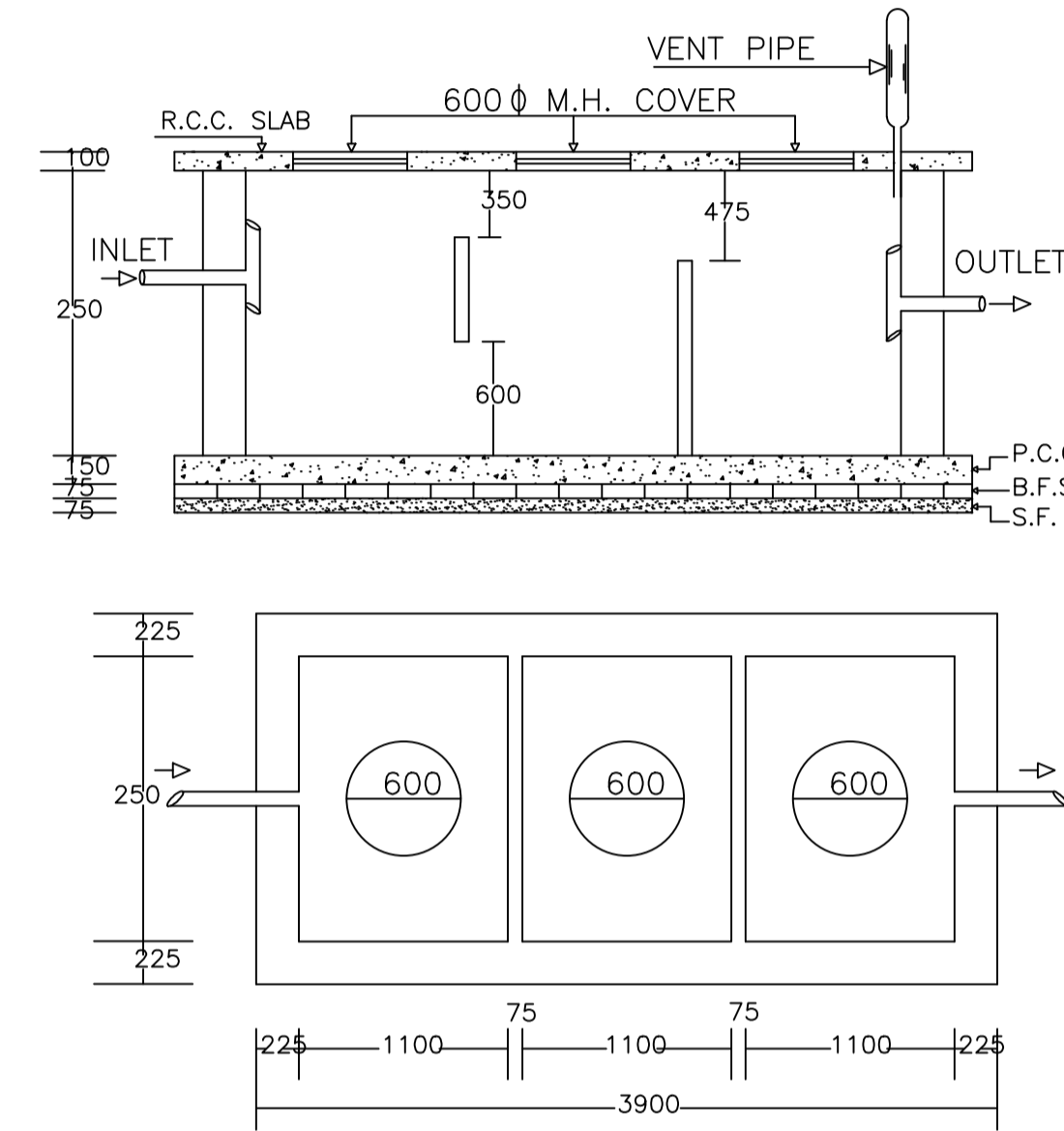

PLAN OF SEPTIC TANK

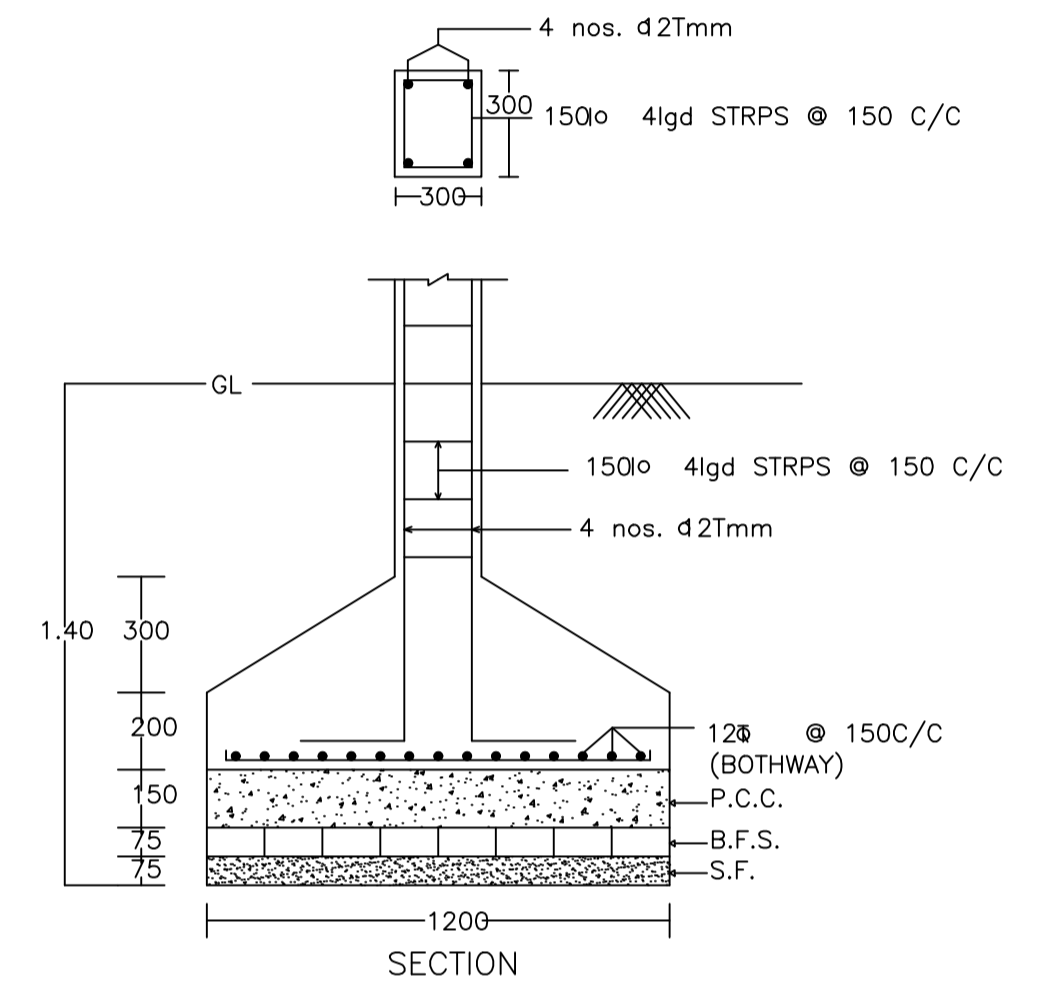

SECTION

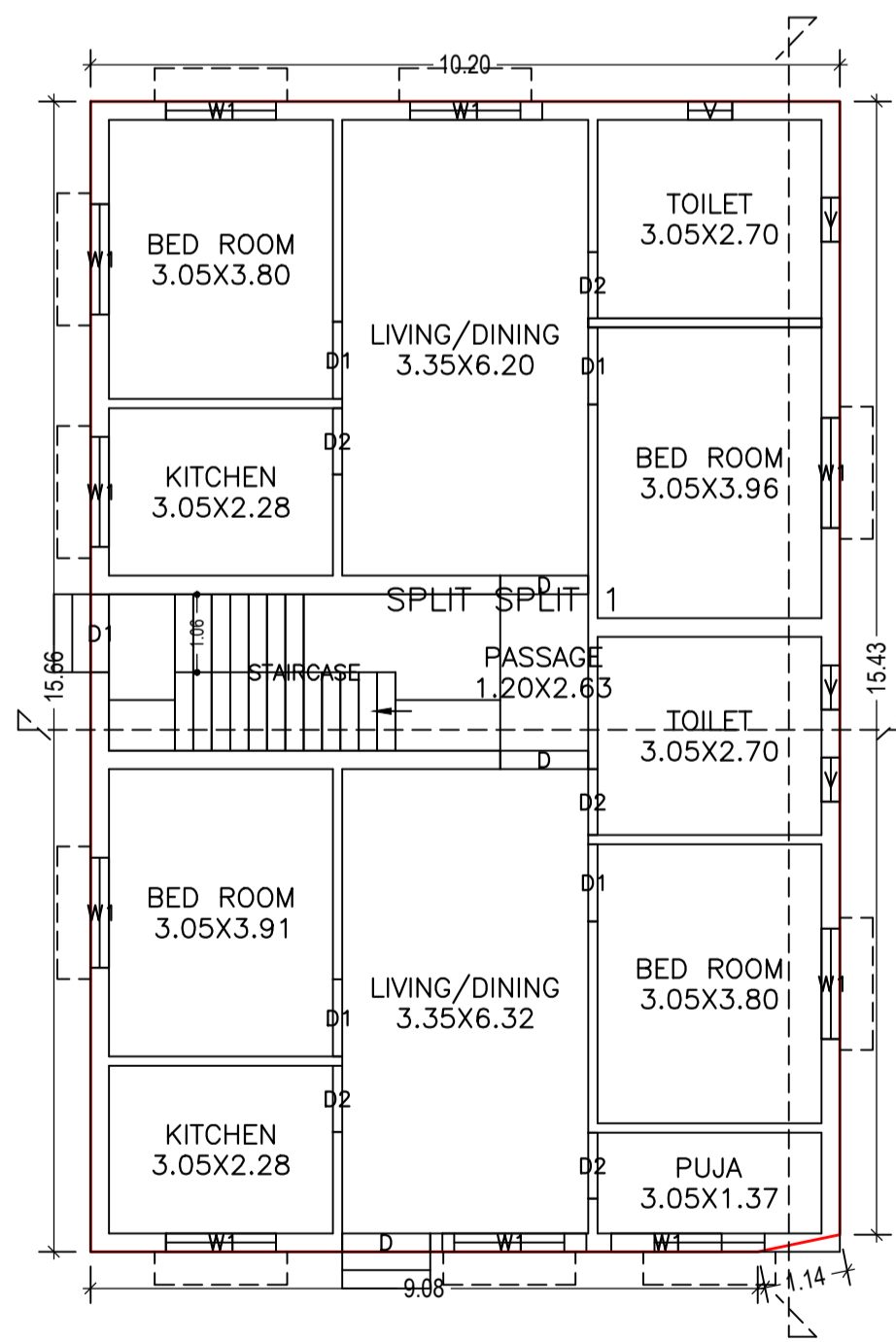

GROUND FLOOR PLAN
(Proposed)
(SCALE 1:100)

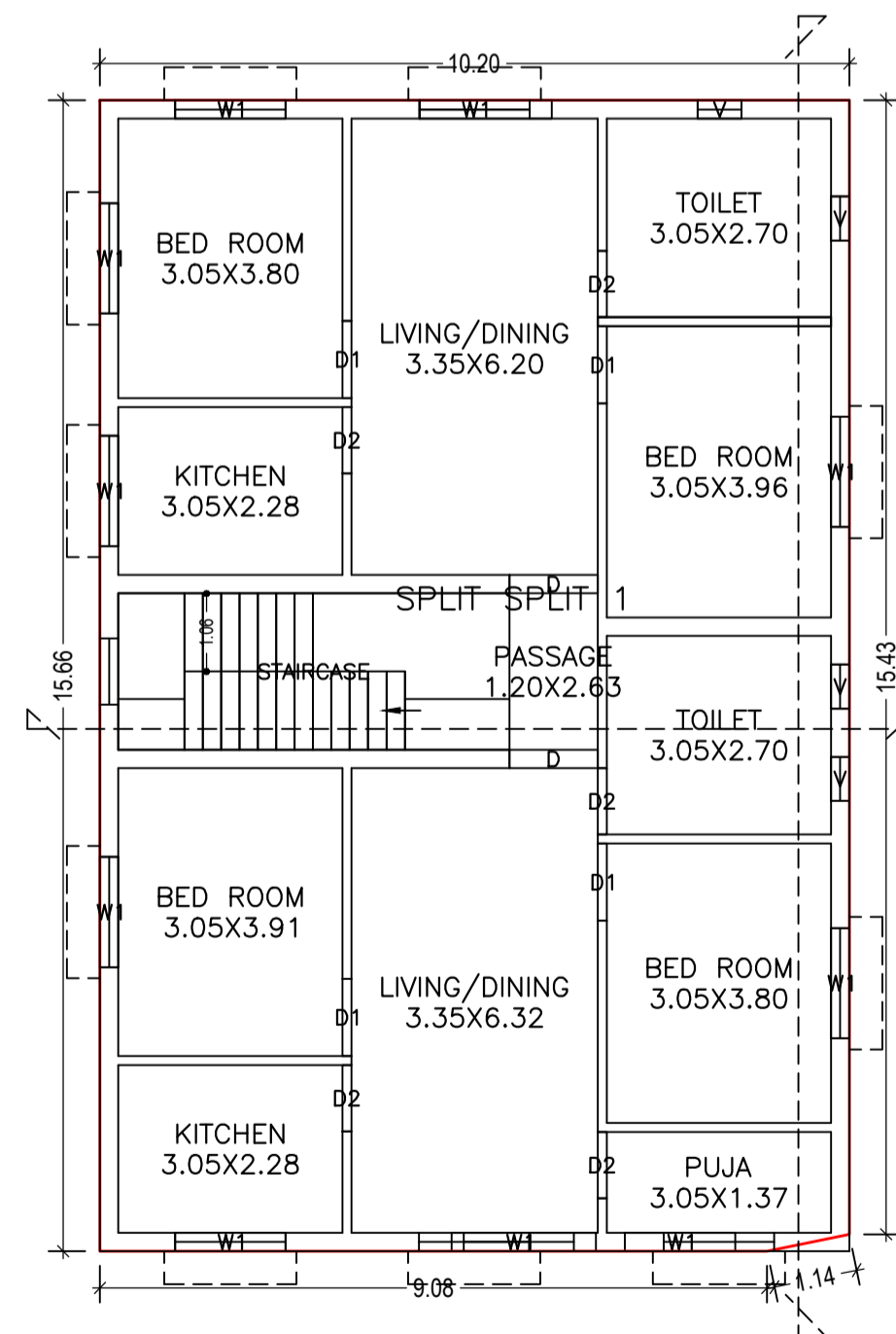

FIRST FLOOR PLAN
(Proposed)
(SCALE 1:100)

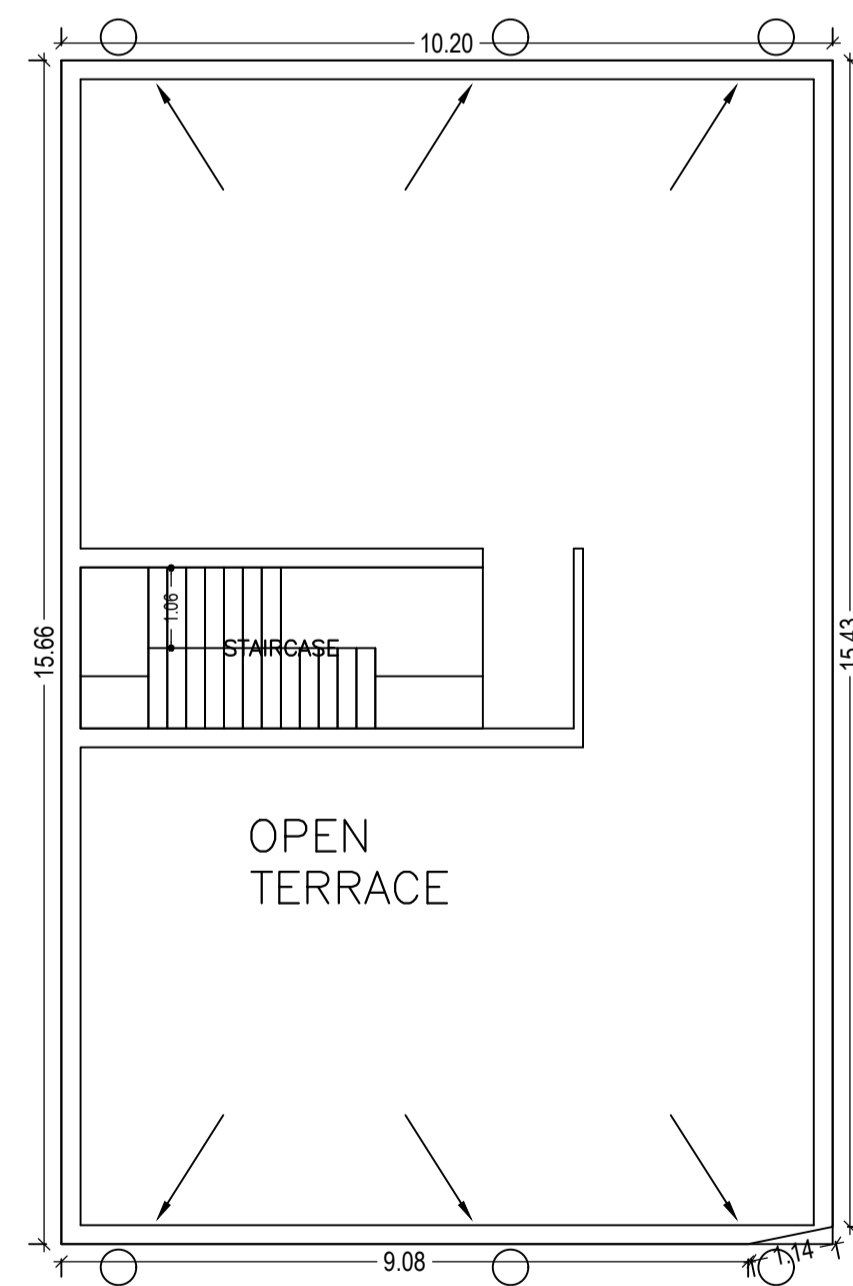

TERRACE FLOOR PLAN
(SCALE 1:100)

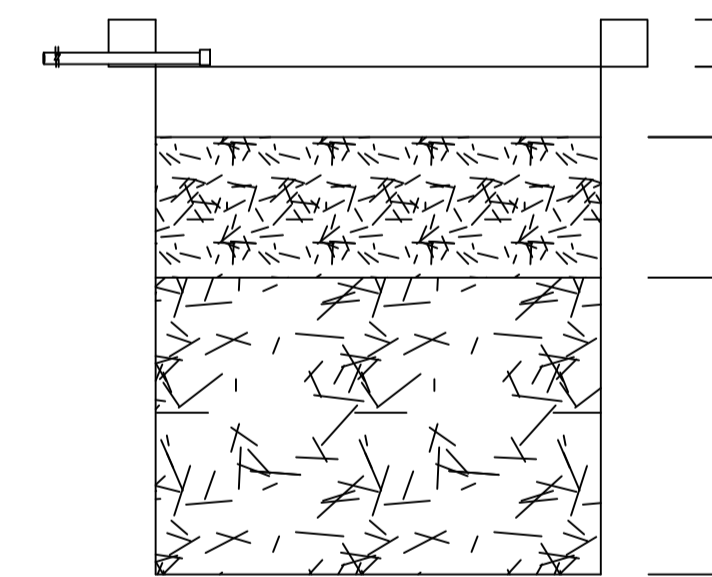

SECTION AT Y-Y

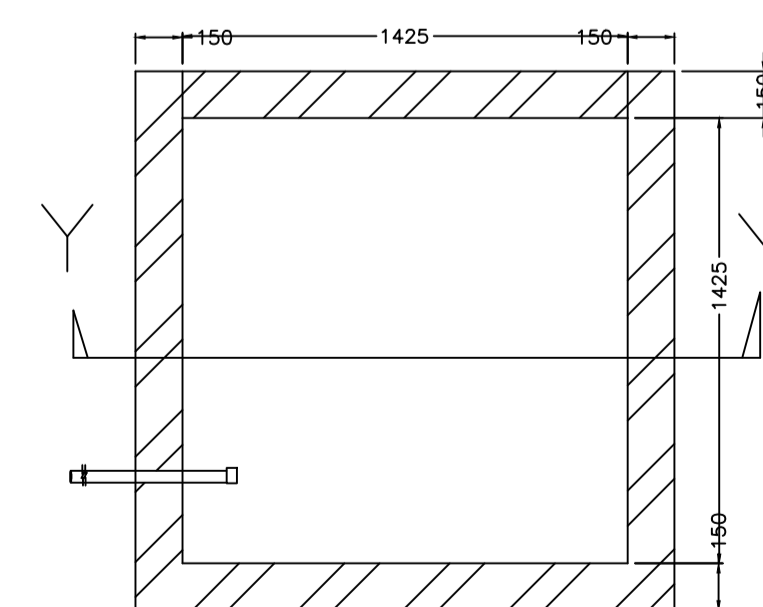

PLAN OF RECHARGE WELL

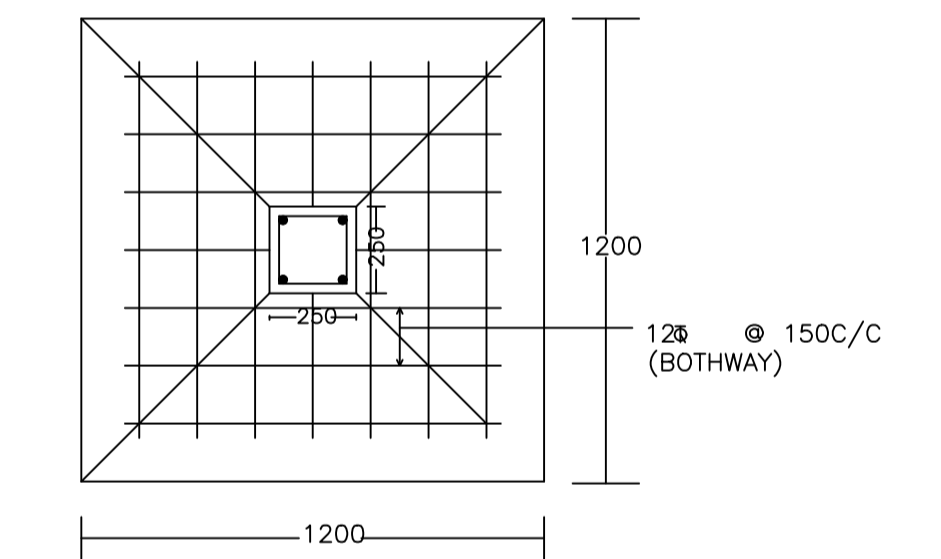

PLAN

DETAIL OF COLUMNS

WATER HARVESTING

LTP NAME AND SIGNATURE	STRUCTURAL ENG'S NAME AND SIGNATURE	BUILDER NAME AND SIGNATURE
PARTHA - PAL DMC/ENG/00212016		