

SITE PLAN  
SCALE: 1:100

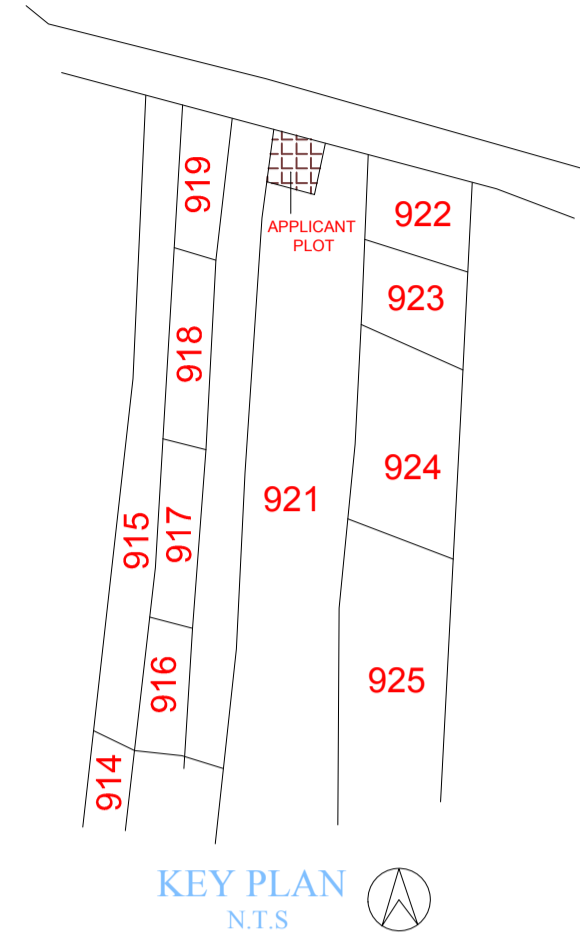

KEY PLAN  
N.T.S.

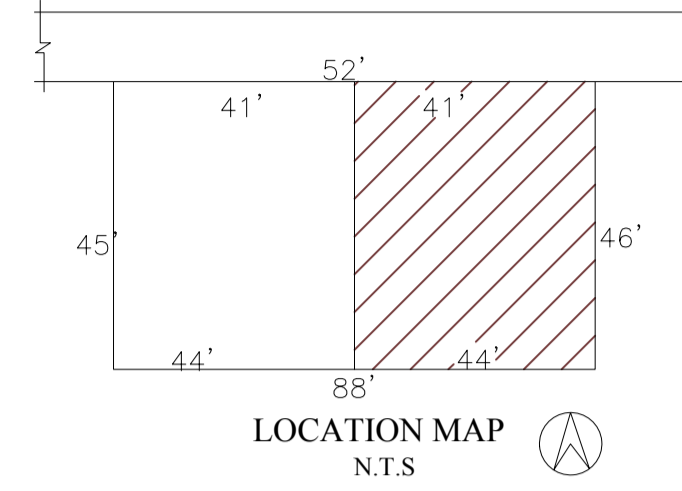

LOCATION MAP  
N.T.S.

SITE PLAN

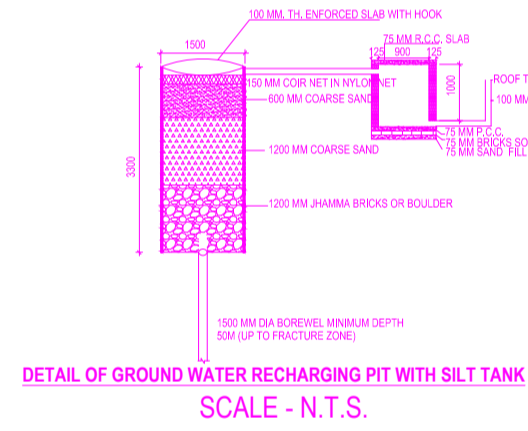

DETAIL OF GROUND WATER RECHARGING PIT WITH SILT TANK  
SCALE - N.T.S.

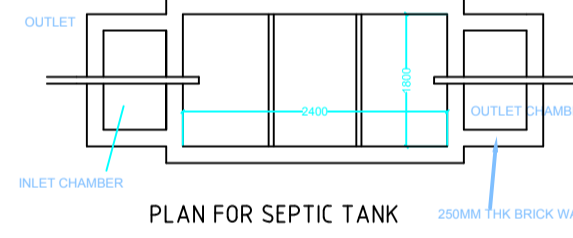

PLAN FOR SEPTIC TANK

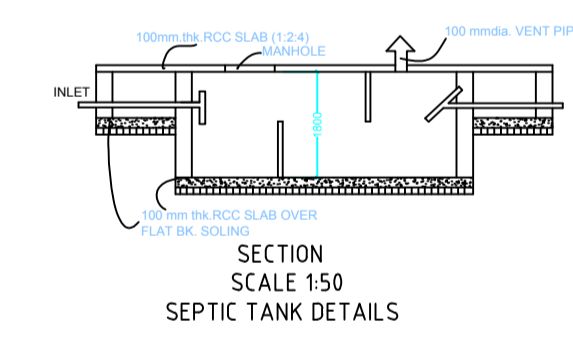

SECTION SCALE 1:50  
SEPTIC TANK DETAILS

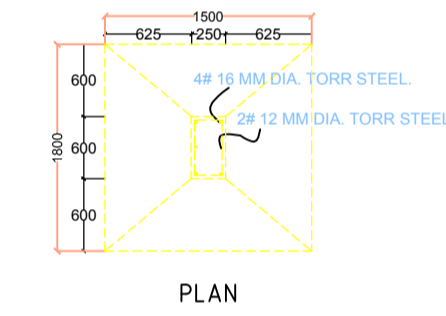

FOUNDATION DETAILS (ISOLATED R.C.C FOOTING)

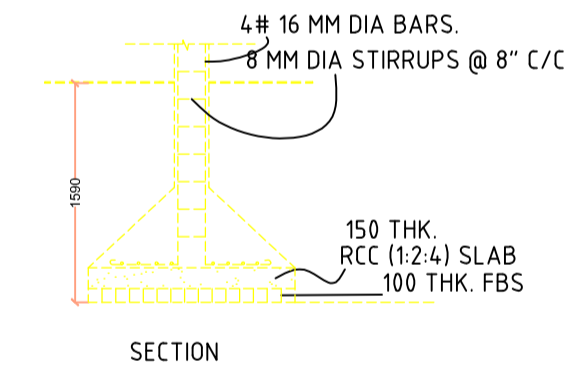

SECTION

Building :A (BUILDING)

Floor Name	Total Built Up Area (Sq.mt.)	Proposed FAR Area (Sq.mt.)	Total FAR Area (Sq.mt.)	Total Consumed Additional FAR Area (Sq.mt.)	Trmt (No.)
Ground Floor	87.85	87.85	87.85	87.85	01
First Floor	87.85	87.85	87.85	87.85	00
Second Floor	87.85	87.85	87.85	87.85	00
Terrace Floor	0.00	0.00	0.00	0.00	00
Total :	263.55	263.55	263.55	263.55	01
Total Number of Same Buildings :	1				
Total :	263.55	263.55	263.55	263.55	01

SCHEDULE OF DOOR:

BUILDING NAME	NAME	LENGTH	HEIGHT	NOS
A (BUILDING)	D1	0.75	2.10	05
A (BUILDING)	D2	0.90	2.10	03
A (BUILDING)	D1	0.98	2.10	05
A (BUILDING)	D	1.05	2.10	07

SCHEDULE OF WINDOW/VENTILATION:

BUILDING NAME	NAME	LENGTH	HEIGHT	NOS
A (BUILDING)	V	0.60	0.60	05
A (BUILDING)	W2	0.60	2.10	08
A (BUILDING)	W1	1.20	1.20	15
A (BUILDING)	W	1.80	1.20	07

THIS IS TO CERTIFY THAT SEISMIC LOADS HAVE BEEN TAKEN UNDER CONSIDERATION WHILE DESIGNING THE STRUCTURE OF THIS BUILDING. THE DESIGN HAS BEEN DONE AS PER I.S. 1893/ 1894 & I.S. 4326/1993

AREA STATEMENT		VERSION NO. : 1.0.18
DHANBAD MUNICIPAL CORPORATION		VERSION DATE: 18/11/2017
PROJECT DETAIL:		
Region: JHARKHAND URBAN LOCAL BODIES	Plot Use: Residential	
District: DHANBAD	Plot SubUse: Boarding	
Authority: DHANBAD MUNICIPAL CORPORATION	PlotNearby/ReligiousStructure: NA	
Inward No: DMC/CP/0078/W/18/2017	Plot/SubPlot No: 921	
Application Type: General Proposal	North: Road Width - 6.67	
Project Type: Building Permission	South: Plot No. - MANORMA SINHA	
Nature of Development: New	East: Plot No. - 921 PART INDU DEVI	
Location of Development Area: Old Area	West: Plot No. - RATAN RAI	
AREA DETAILS:		
AREA OF PLOT (Minimum)	(A)	SQ.MT. 163.84
Deduction for NetPlot Area		
Road Widening Area		5.14
Total		5.14
NET AREA OF PLOT(Gross Plot Area - Deduction from Gross Plot area)	(A-Deductions)	158.70
Deduction for Balance Plot Area(from Gross Plot Area)		
Road Widening Area		5.14
Common Plot		17.09
Total		22.22
BALANCE AREA OF PLOT(Net Plot Area - Recreational/Amenity space)	(A-Deductions)	141.62
PLOT AREA FOR COVERAGE(Net Plot Area)	(A-Deductions)	158.70
Plot Area for FAR (Net Plot Area + RoadWidening Area)	(A-Deductions)	158.70
COVERAGE CHECK		
Permissible Coverage area ( 70.00 % )		111.09
Proposed Coverage Area ( 55.35 % )		87.85
Total Prop. Coverage Area ( 55.35 % )		87.85
Balance coverage area ( 14.64 % )		23.24
FAR CHECK		
Perm. FAR Area ( 2.50 )		396.76
Total Perm. FAR area		396.76
Residential FAR		263.54
Proposed FAR Area		263.54
Total Proposed FAR Area		263.54
Consumed FAR (Factor)		1.66
Balance FAR Area		133.22
BUILT UP AREA CHECK		
Total Proposed BuiltUp Area		263.55
ARCHITECT (Regd)		GOPIKANT MAHATO
ENGINEER (Regd)		
SUPERVISOR (Regd)		
OWNER (Regd)		SMT. RENU CHOUDHARY
DEVELOPMENT AUTHORITY		LOCAL BODY

COLOR INDEX	
PLOT BOUNDARY	Black
ABUTTING ROAD	Red
PROPOSED CONSTRUCTION	Green
COMMON PLOT	Yellow
ROAD WIDENING AREA	Blue
EXISTING (To be retained)	White
EXISTING (To be demolished)	Grey

Buildingwise Floor FAR Details

Floor Name	Building Name A (BUILDING)		Total	
	Proposed Built Up Area (Sq.mt.)	Proposed FAR Area (Sq.mt.)	Total FAR Area (Sq.mt.)	Total FAR Area (Sq.mt.)
Ground Floor	87.85	87.85	87.85	87.85
First Floor	87.85	87.85	87.85	87.85
Second Floor	87.85	87.85	87.85	87.85
Terrace Floor	0.00	0.00	0.00	0.00
Total :	263.55	263.55	263.55	263.55

Building USE/SUBUSE Details

Building Name	Building Use	Building SubUse	Building Structure
A (BUILDING)	Residential	Residential Bldg/Apartment	Non-Highrise

FAR & Tenement Details (Table 4c-1)

Building	No. of Same Bldg	Total Built Up Area (Sq.mt.)	Proposed FAR Area (Sq.mt.)	Total FAR Area (Sq.mt.)	Total Consumed Additional FAR Area (Sq.mt.)	Trmt (No.)
A (BUILDING)	1	263.55	263.55	263.55	263.55	01
Grand Total :	1	263.55	263.55	263.55	263.55	01

UnitBUA Table for Building :A (BUILDING)

FLOOR	Name	UnitBUA Type	UnitBUA Area	Carpet Area	No. of Rooms	No. of Tenement
GROUND FLOOR PLAN	SPLIT A	FLAT	191.61	170.27	4	1
TYPICAL - 1& 2 FLOOR PLAN	SPLIT A	FLAT	0.00	0.00	8	0
Total:	-	-	191.61	170.27	20	1

LTP NAME AND SIGNATURE	STRUCTURAL ENG'S NAME AND SIGNATURE	BUILDER NAME AND SIGNATURE
GOPIKANT MAHATO DMC/ARC/0001/2016		

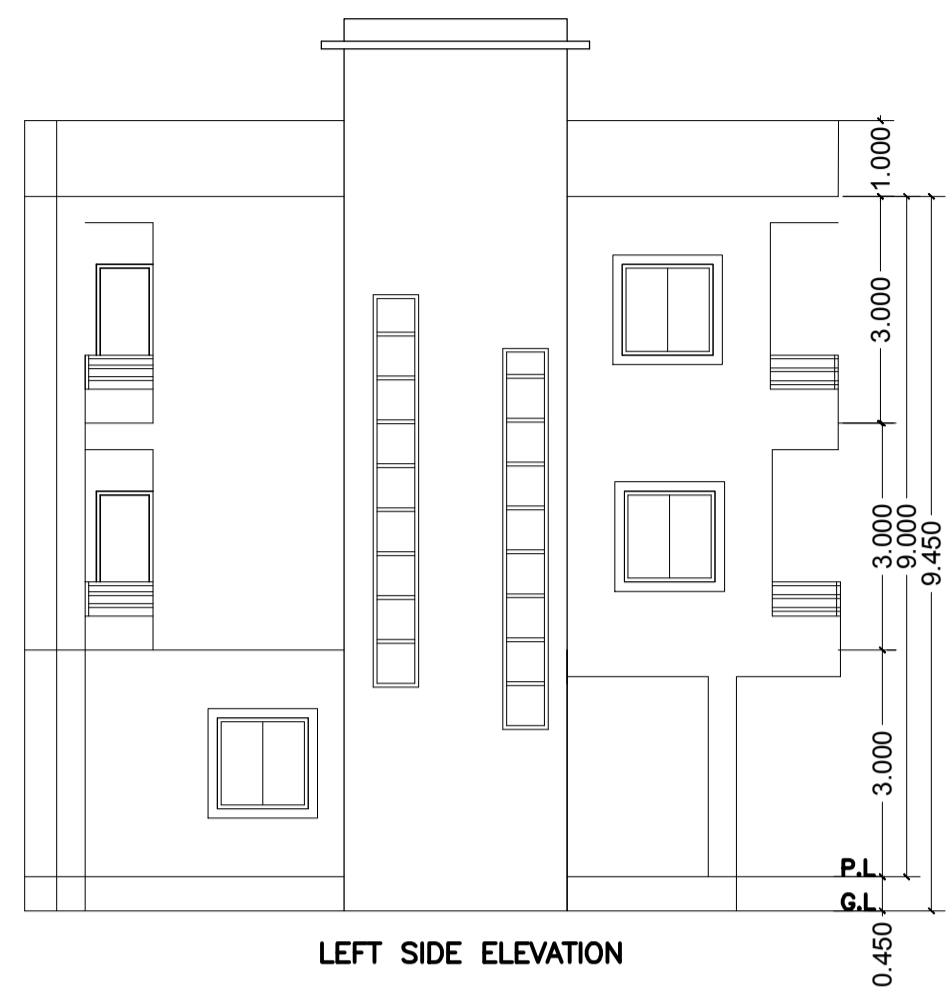

LEFT SIDE ELEVATION

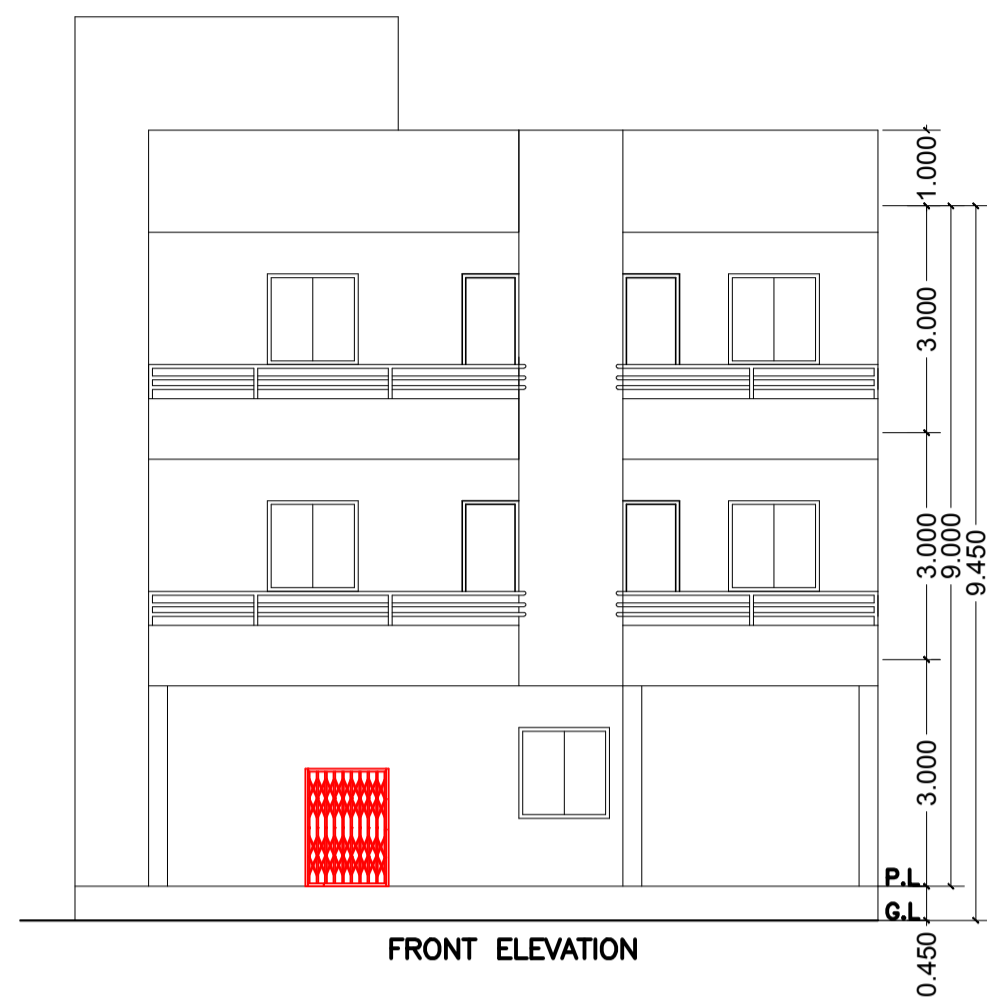

FRONT ELEVATION

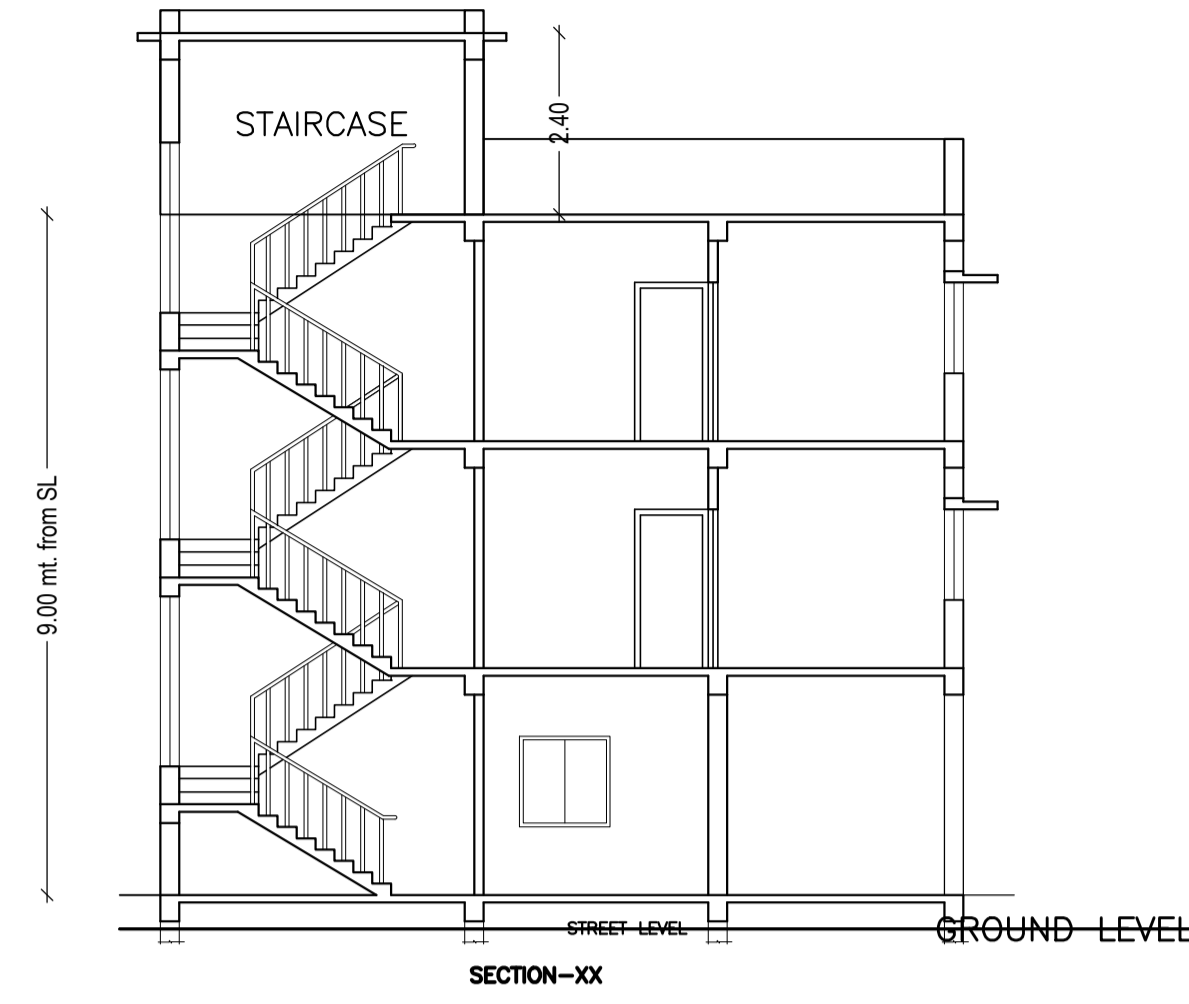

SECTION-XX

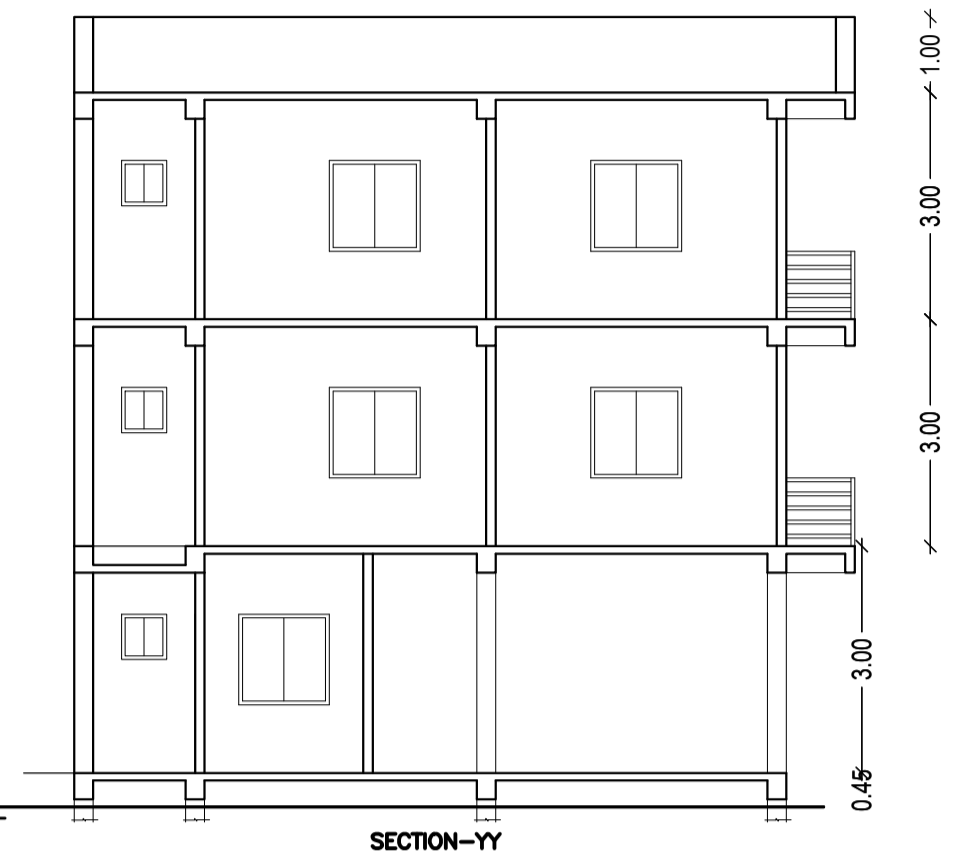

SECTION-YY

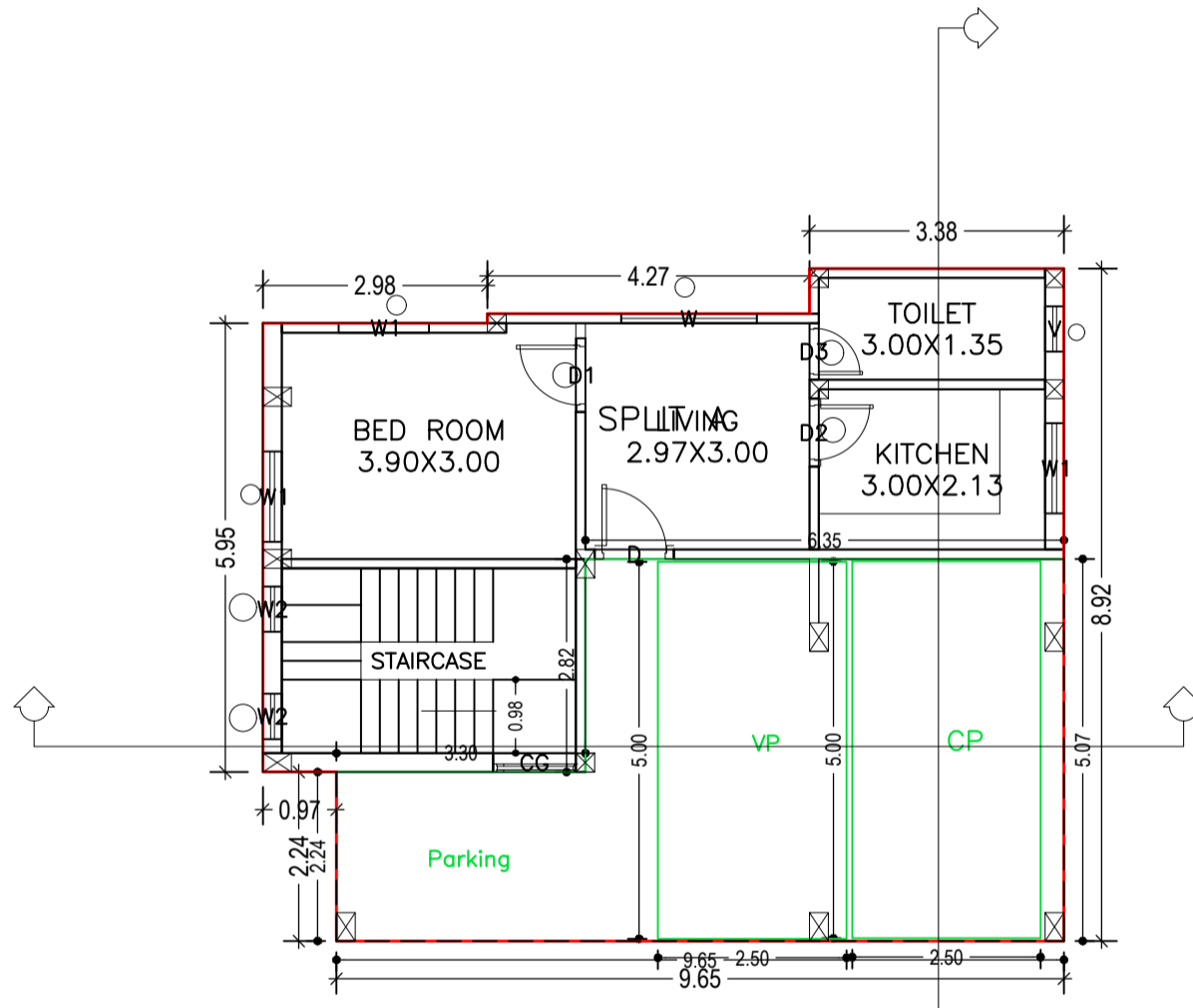

GROUND FLOOR PLAN (Proposed) (SCALE 1:100)

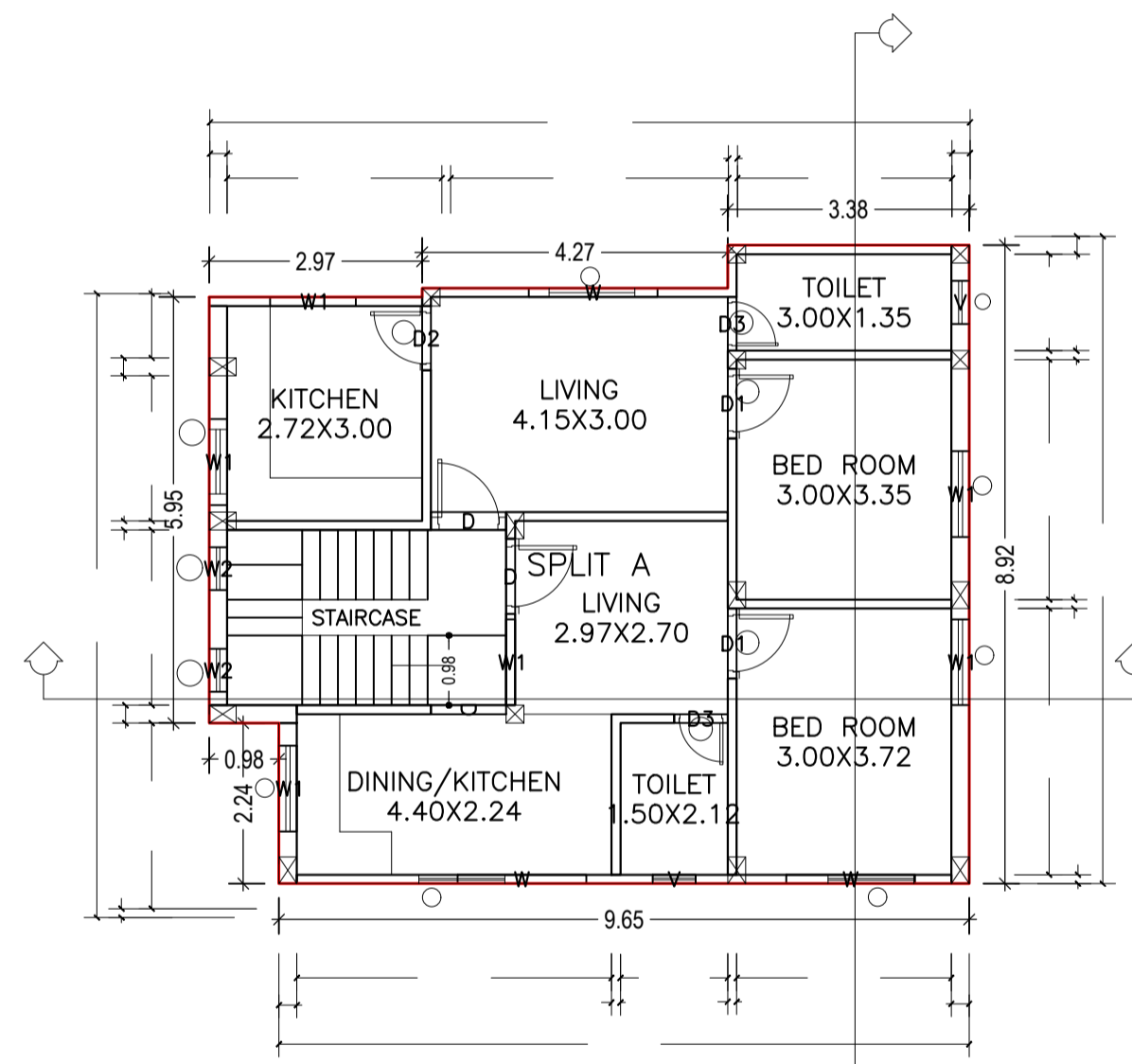

TYPICAL - 1& 2 FLOOR PLAN (Proposed) (SCALE 1:100)

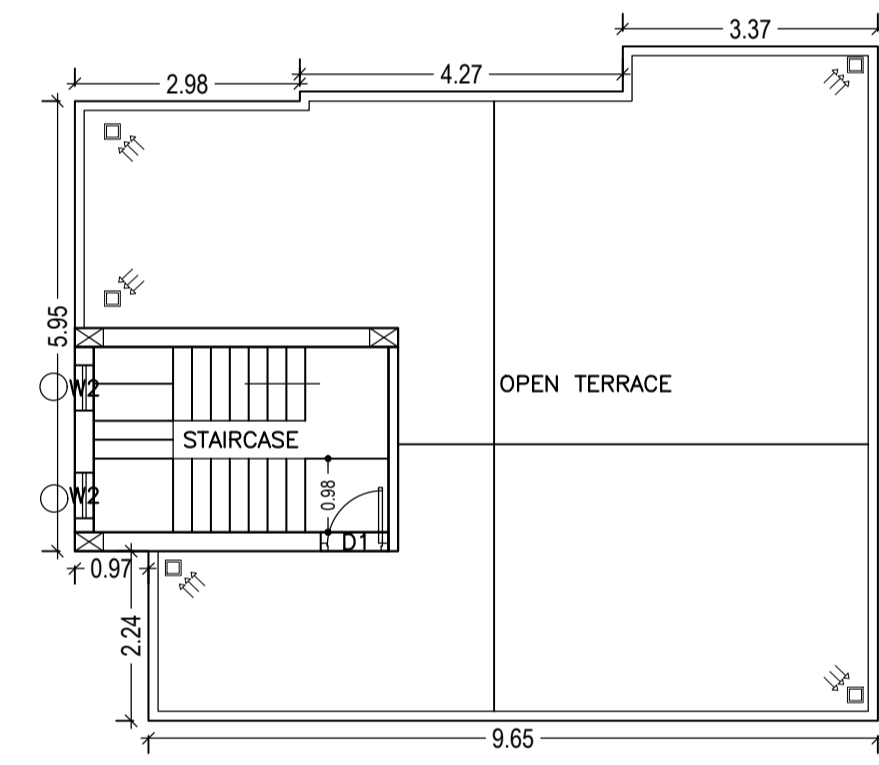

TERRACE FLOOR PLAN (SCALE 1:100)

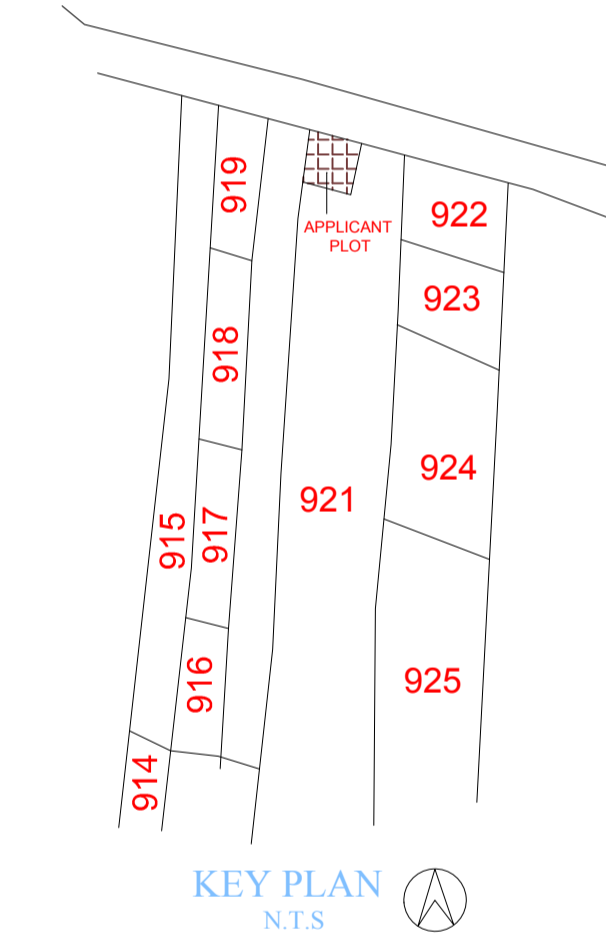

KEY PLAN N.T.S.

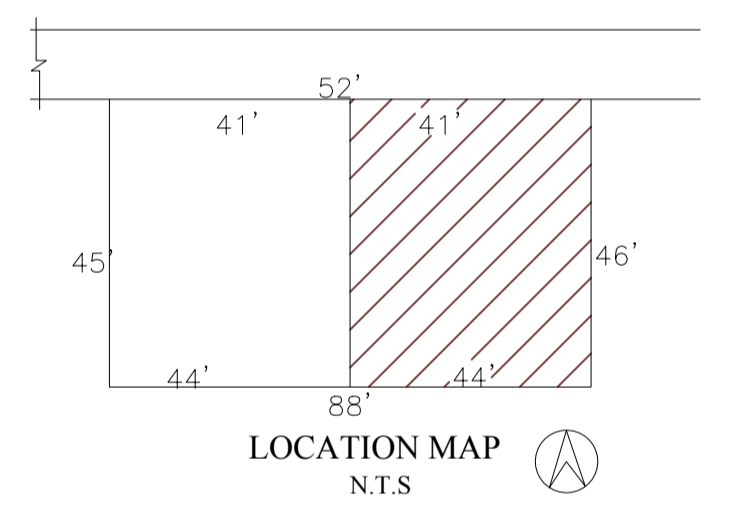

LOCATION MAP N.T.S.

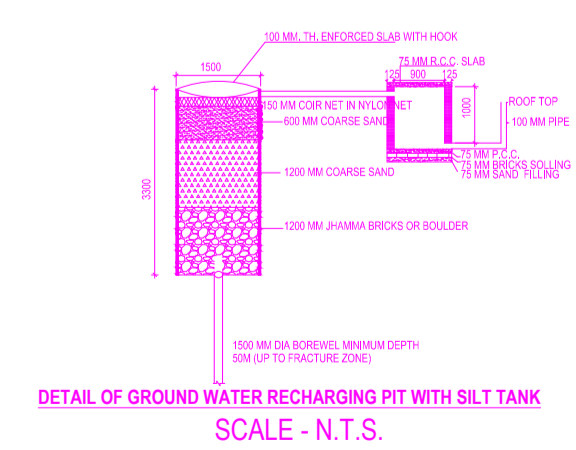

DETAIL OF GROUND WATER RECHARGING PIT WITH SILT TANK SCALE - N.T.S.

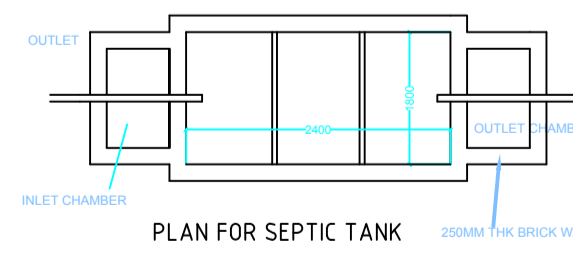

PLAN FOR SEPTIC TANK

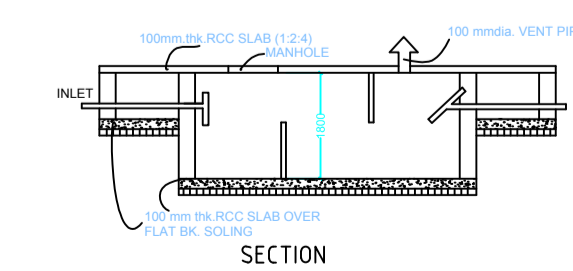

SECTION 150 SEPTIC TANK DETAILS

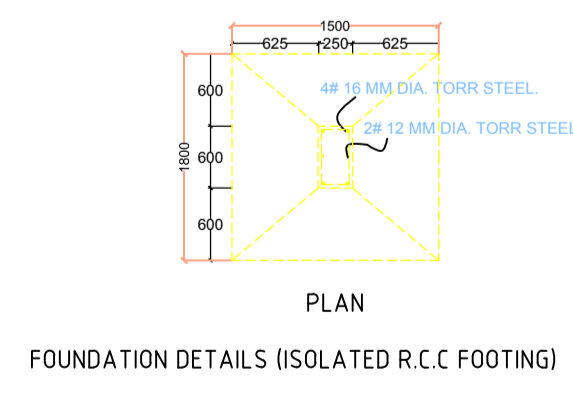

PLAN

FOUNDATION DETAILS (ISOLATED R.C.C FOOTING)

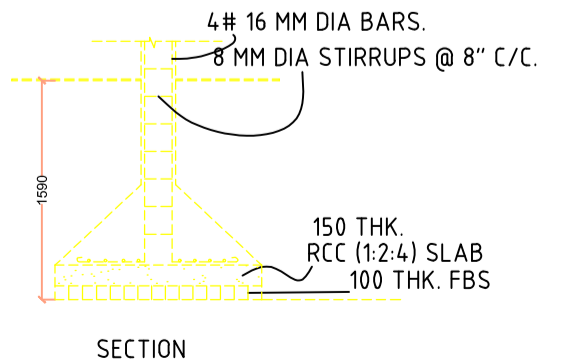

SECTION

LTP NAME AND SIGNATURE	STRUCTURAL ENG'S NAME AND SIGNATURE	BUILDER NAME AND SIGNATURE
GOPIKANT MAHATO DMCI/ARC/0001/2016		