

AREA STATEMENT (DHANBAD MUNICIPAL CORPORATION)		VERSION NO.: 1.0.14
PROJECT DETAIL :		VERSION DATE: 11/07/2017
Region: JHARKHAND URBAN LOCAL BODIES	Plot Use: Residential	
District: DHANBAD	Plot SubUse: Residential Bldg/Apartment	
Authority: DHANBAD MUNICIPAL CORPORATION	Plot/Nearby/Religious Structure: NA	
Inward No: DMC/BP/0094/W21/2017	Plot/Su/Plot No: 702	
Application Type: General Proposal	North: Plot No - 696, 697	
Project Type: Building Permission	South: Road Width - 3.66	
Nature of Development: New	East: Plot No. - 703	
Location of Development Area: Old Area	West: Plot No. - 702	
AREA DETAILS :		SQ.MT.
AREA OF PLOT (Minimum)	(A)	129.41
NET AREA OF PLOT (Gross Plot Area - Deduction from Gross Plot area)	(A-Deductions)	129.41
Deduction for Balance Plot Area (from Gross Plot Area)		
Common Plot		17.79
Total		17.79
BALANCE AREA OF PLOT (Net Plot Area - Recreational/Amenity space)	(A-Deductions)	111.62
PLOT AREA FOR COVERAGE (Net Plot Area)	(A-Deductions)	129.41
Plot Area for FAR (Net Plot Area + Road Widening Area)	(A-Deductions)	129.41
COVERAGE CHECK		
Permissible Coverage area (70.00 %)		90.59
Proposed Coverage Area (56.44 %)		73.04
Total Prop. Coverage Area (56.44 %)		73.04
Balance coverage area (13.56 %)		17.55
FAR CHECK		
Perm. FAR Area (1.50)		194.12
Total Perm. FAR area		194.12
Residential FAR		146.08
Proposed FAR Area		146.08
Total Proposed FAR Area		146.08
Consumed FAR (Factor)		1.13
Balance FAR Area		48.04
BUILT UP AREA CHECK		
Total Proposed BuiltUp Area		146.08
ARCHITECT (Regd)		KUMARI RINKU RANI
ENGINEER (Regd)		
SUPERVISOR (Regd)		
OWNER (Regd)		SRI PRADIP KUMAR CHATTERJEE
DEVELOPMENT AUTHORITY		LOCAL BODY

COLOR INDEX	
PLOT BOUNDARY	Black
ABUTTING ROAD	Green
PROPOSED CONSTRUCTION	Red
COMMON PLOT	Yellow
ROAD WIDENING AREA	Blue
EXISTING (To be retained)	Light Blue
EXISTING (To be demolished)	Light Yellow

Buildingwise Floor FAR Details				
Floor Name	Building Name		Total	
	Proposed Built Up Area (Sq.mt.)	Proposed FAR Area (Sq.mt.)	Total Proposed Built Up Area (Sq.mt.)	Total FAR Area (Sq.mt.)
Ground Floor	73.04	73.04	73.04	73.04
First Floor	73.04	73.04	73.04	73.04
Terrace Floor	0.00	0.00	0.00	0.00
Total :	146.08	146.08	146.08	146.08

Building USE/SUBUSE Details			
Building Name	Building Use	Building SubUse	Building Structure
A (A)	Residential	Residential Bldg/Apartment	Non-Highrise

FAR & Tenement Details (Table 4c-1)						
Building	No. of Same Bldg	Total Built Up Area (Sq.mt.)	Proposed FAR Area (Sq.mt.)	Total FAR Area (Sq.mt.)	Total Consumed Additional FAR Area (Sq.mt.)	Tnmt (No.)
			Resi.			
A (A)	1	146.08	146.08	146.08	146.08	01
Grand Total :	1	146.08	146.08	146.08	146.08	1.00

Building : A (A)					
Floor Name	Total Built Up Area (Sq.mt.)	Proposed FAR Area (Sq.mt.)	Total FAR Area (Sq.mt.)	Total Consumed Additional FAR Area (Sq.mt.)	Tnmt (No.)
		Resi.			
Ground Floor	73.04	73.04	73.04	73.04	01
First Floor	73.04	73.04	73.04	73.04	00
Terrace Floor	0.00	0.00	0.00	0.00	00
Total :	146.08	146.08	146.08	146.08	01
Total Number of Same Buildings :	1				
Total :	146.08	146.08	146.08	146.08	01

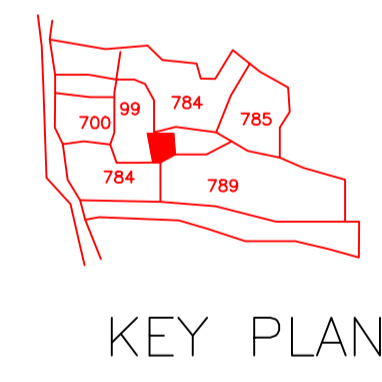

SCHEDULE OF DOOR:				
BUILDING NAME	NAME	LENGTH	HEIGHT	NOS
A (A)	D	0.79	2.10	02
A (A)	D	1.00	2.10	08
A (A)	D1	1.00	2.10	02

SCHEDULE OF WINDOW/VENTILATION:				
BUILDING NAME	NAME	LENGTH	HEIGHT	NOS
A (A)	W	1.29	1.20	02
A (A)	W	1.50	1.20	21

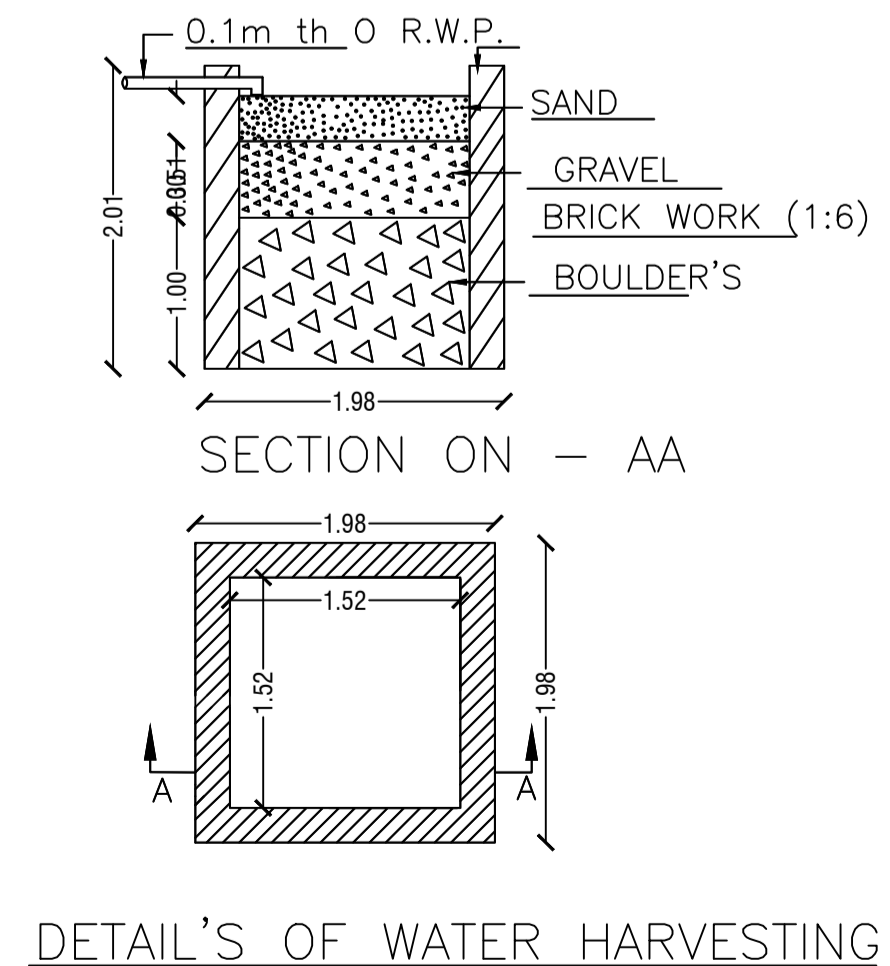
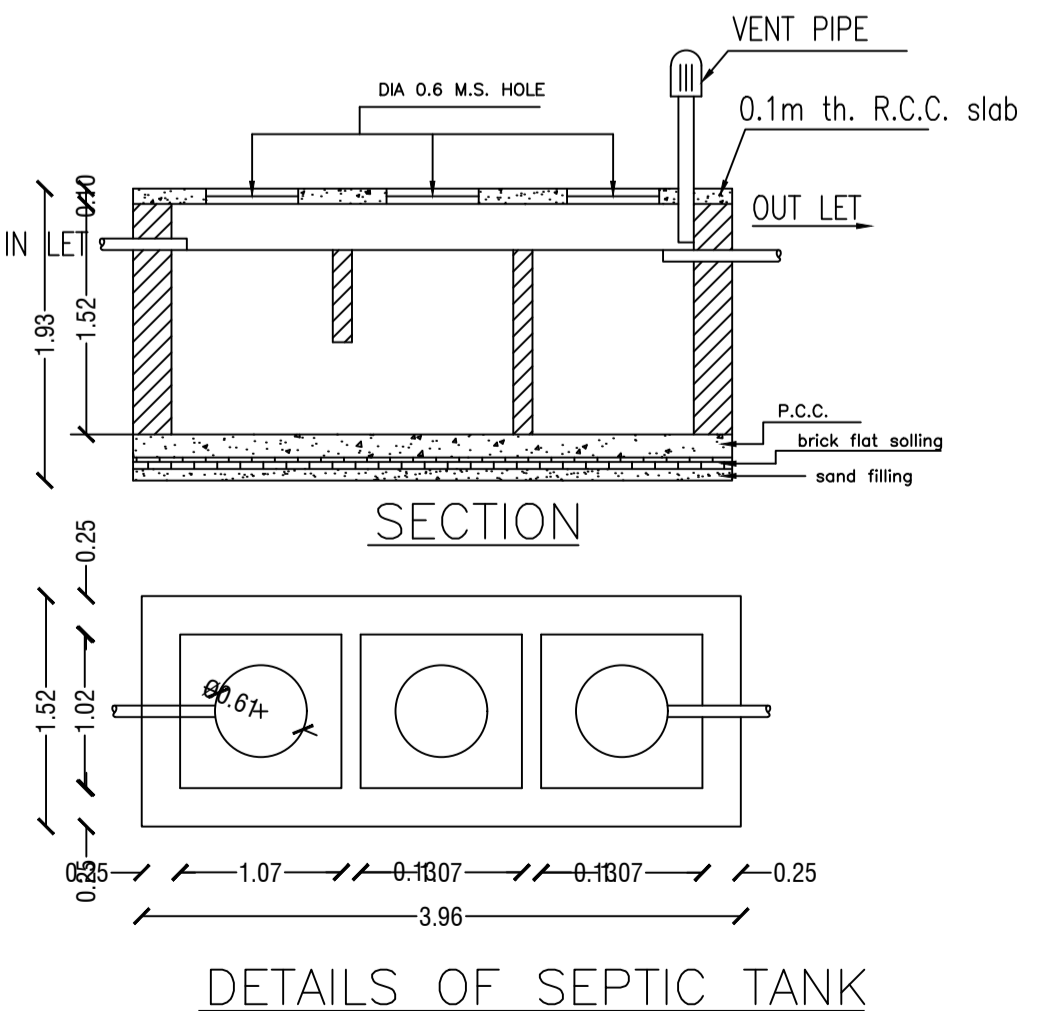

LTP NAME AND SIGNATURE	STRUCTURAL ENG'S NAME AND SIGNATURE	BUILDER NAME AND SIGNATURE
KUMARI RINKU RANI DMC/ENG/0016/2016		