

GROUND FLOOR PLAN (Proposed) (SCALE 1:100)

FIRST FLOOR PLAN (Proposed) (SCALE 1:100)

TERRACE FLOOR PLAN (SCALE 1:100)

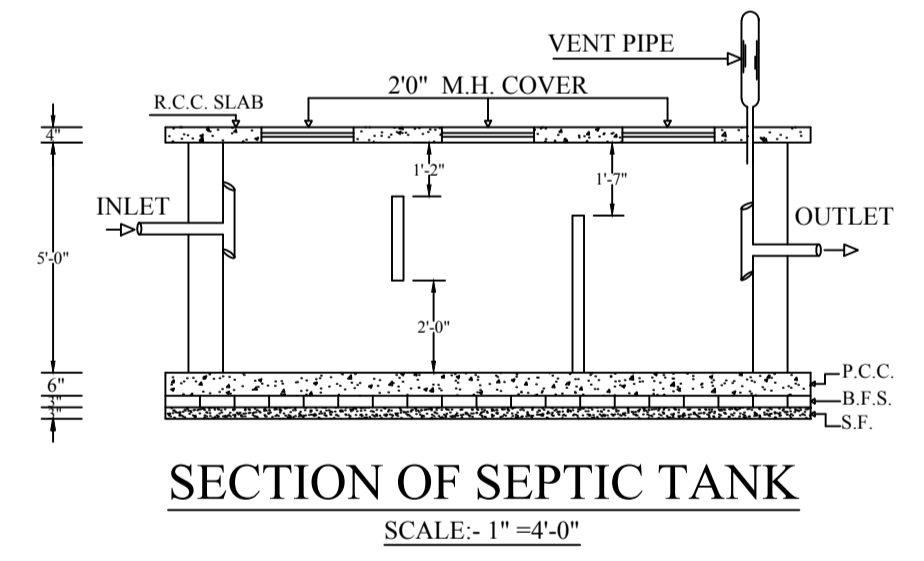
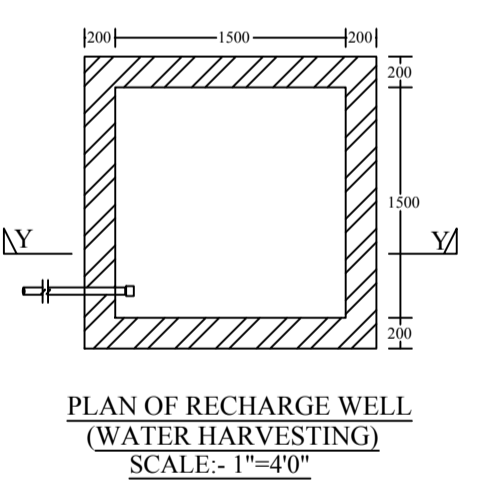
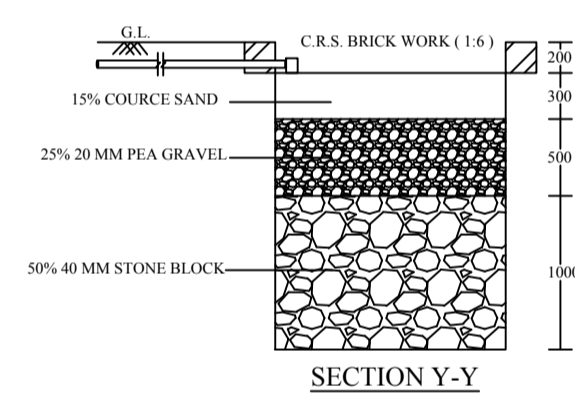

SECTION OF SEPTIC TANK (SCALE:- 1" = 4'-0")

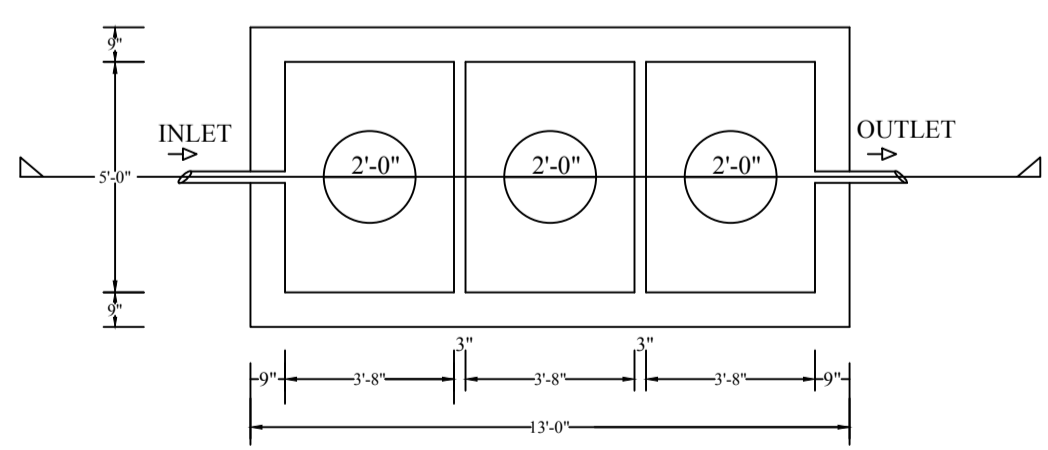

PLAN OF SEPTIC TANK (SCALE:- 1" = 4'-0")

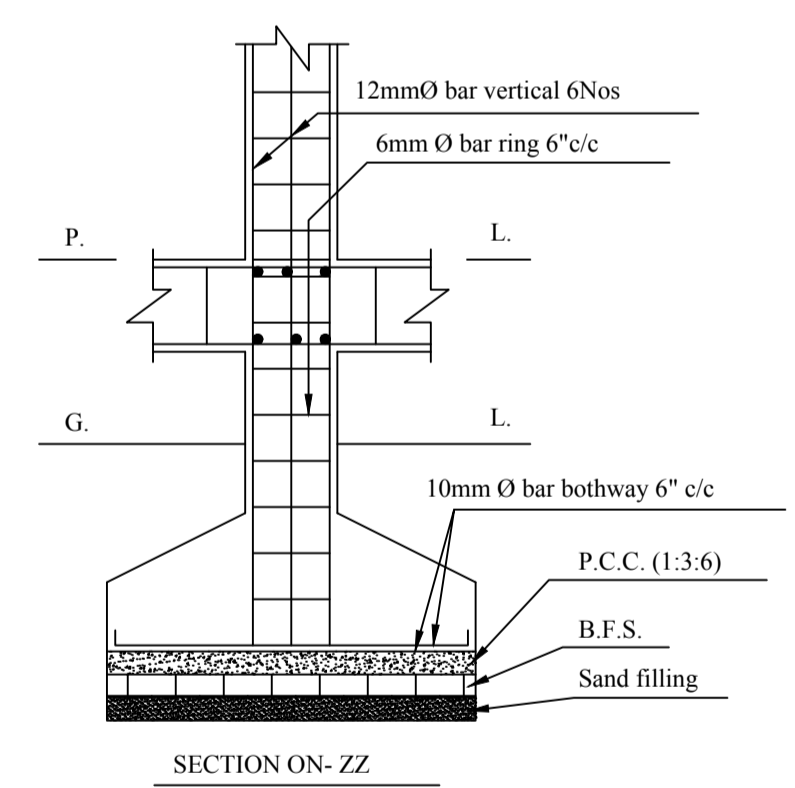

SECTION ON-ZZ

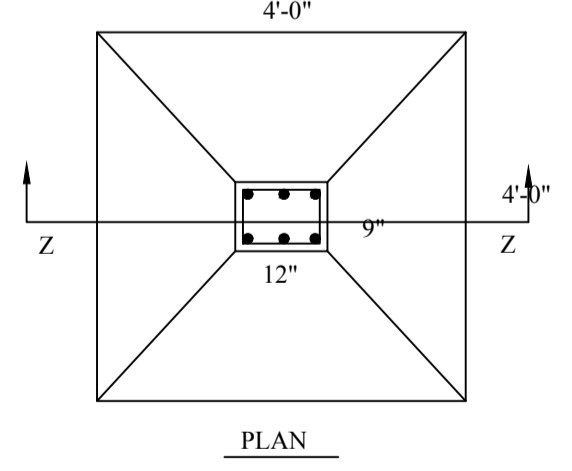

PLAN

*DETAILS OF COLUMN FOOTING (SCALE :- 1" = 2'-0")

AREA STATEMENT (DHANBAD MUNICIPAL CORPORATION)	VERSION NO.: 1.0.14	VERSION DATE: 11/07/2017
PROJECT DETAIL:	Region: JHARKHAND URBAN LOCAL BODIES	Plot Use: Residential
	District: DHANBAD	Plot SubUse: Residential Bldg/Apartment
	Authority: DHANBAD MUNICIPAL CORPORATION	PlotNearby/Religious/Structure: NA
	Inward No: DMC/BP/0063/W18/2017	Plot/SubPlot No: 1879
	Application Type: General Proposal	North: Survey No. - Hafiz Rizwan
	Project Type: Building Permission	South: Road Width - 3.66
	Nature of Development: New	East: Survey No. - Hasim & Kasim
	Location of Development Area: New Area	West: Survey No. - Anjum Ara
AREA DETAILS:		SQ.MT.
AREA OF PLOT (Minimum)	(A)	133.08
NET AREA OF PLOT (Gross Plot Area - Deduction from Gross Plot area)	(A-Deductions)	133.08
Deduction for Balance Plot Area (from Gross Plot Area)		
Common Plot		21.28
Total		21.28
BALANCE AREA OF PLOT (Net Plot Area - Recreational/Amenity space)	(A-Deductions)	111.80
PLOT AREA FOR COVERAGE (Net Plot Area)	(A-Deductions)	133.08
Plot Area for FAR (Net Plot Area + Road Widening Area)	(A-Deductions)	133.08
COVERAGE CHECK		
Permissible Coverage area (70.00 %)		93.16
Proposed Coverage Area (62.61 %)		83.32
Total Prop. Coverage Area (62.61 %)		83.32
Balance coverage area (7.39 %)		9.84
FAR CHECK		
Perm. FAR Area (1.50)		199.62
Total Perm. FAR area		199.62
Residential FAR		140.78
Proposed FAR Area		140.78
Total Proposed FAR Area		140.78
Consumed FAR (Factor)		1.06
Balance FAR Area		58.84
BUILT UP AREA CHECK		
Total Proposed BuiltUp Area		166.64
ARCHITECT (Regd)		MANISH KUMAR SINGH
ENGINEER (Regd)		
SUPERVISOR (Regd)		
OWNER (Regd)		Mohammad Mehrab Siddiqui
DEVELOPMENT AUTHORITY		LOCAL BODY

COLOR INDEX	
PLOT BOUNDARY	Black
ABUTTING ROAD	Green
PROPOSED CONSTRUCTION	Red
COMMON PLOT	Yellow
ROAD WIDENING AREA	Blue
EXISTING (To be retained)	Light Blue
EXISTING (To be demolished)	Light Yellow

Floor Name	Building Name A (BUILDING)		Total	
	Proposed Built Up Area (Sq.mt.)	Proposed FAR Area (Sq.mt.)	Total Proposed Built Up Area (Sq.mt.)	Total FAR Area (Sq.mt.)
Ground Floor	83.32	57.46	83.32	57.46
First Floor	83.32	83.32	83.32	83.32
Terrace Floor	0.00	0.00	0.00	0.00
Total :	166.64	140.78	166.64	140.78

Building USE/SUBUSE Details			
Building Name	Building Use	Building SubUse	Building Structure
A (BUILDING)	Residential	Residential Bldg/Apartment	Non-Highrise

FAR & Tenement Details (Table 4c-1)							
Building	No. of Same Bldg	Total Built Up Area (Sq.mt.)	Deductions (Area in Sq.mt.)	Proposed FAR Area (Sq.mt.)	Total FAR Area (Sq.mt.)	Total Consumed Additional FAR Area (Sq.mt.)	Trmt (No.)
A (BUILDING)	1	166.64	25.86	140.78	140.78	140.78	01
Grand Total :	1	166.64	25.86	140.78	140.78	140.78	1.00

Building :A (BUILDING)						
Floor Name	Total Built Up Area (Sq.mt.)	Deductions (Area in Sq.mt.)	Proposed FAR Area (Sq.mt.)	Total FAR Area (Sq.mt.)	Total Consumed Additional FAR Area (Sq.mt.)	Trmt (No.)
Ground Floor	83.32	25.86	57.46	57.46	57.46	01
First Floor	83.32	0.00	83.32	83.32	83.32	00
Terrace Floor	0.00	0.00	0.00	0.00	0.00	00
Total :	166.64	0.00	140.78	140.78	140.78	01
Total Number of Same Buildings	1					
Total :	166.64	25.86	140.78	140.78	140.78	01

SCHEDULE OF DOOR:				
BUILDING NAME	NAME	LENGTH	HEIGHT	NOS
A (BUILDING)	D3	0.76	2.10	03
A (BUILDING)	D2	0.91	2.10	02
A (BUILDING)	D1	1.07	2.10	08
SCHEDULE OF WINDOW/VENTILATION:				
BUILDING NAME	NAME	LENGTH	HEIGHT	NOS
A (BUILDING)	V	0.67	1.20	03
A (BUILDING)	W2	1.22	1.20	02
A (BUILDING)	W1	1.83	1.20	14

LTP NAME AND SIGNATURE
MANISH KUMAR SINGH
DMC/ENG/0003/2016

STRUCTURAL ENG'S NAME AND SIGNATURE

BUILDER NAME AND SIGNATURE