

site plan

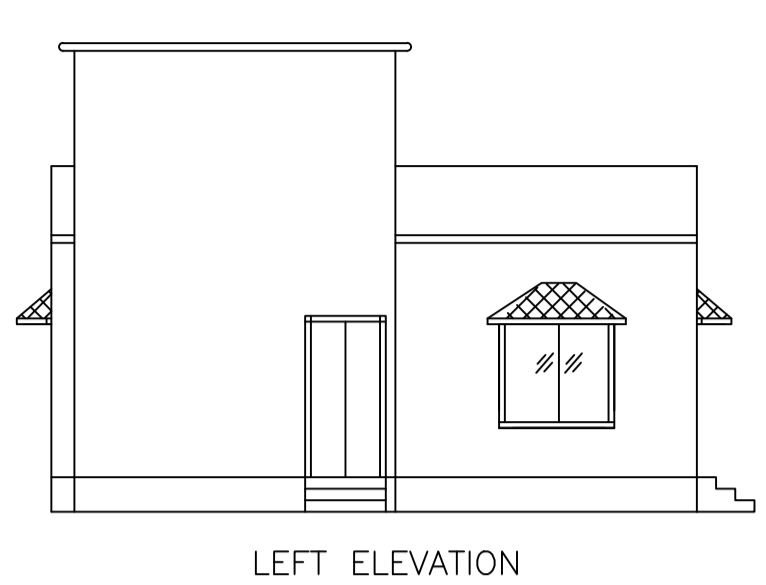

LEFT ELEVATION



FRONT ELEVATION

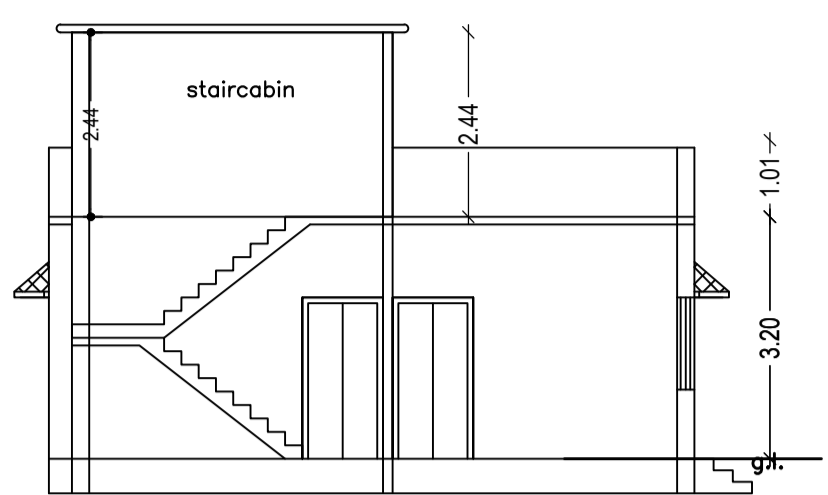

SECTION ON X-X

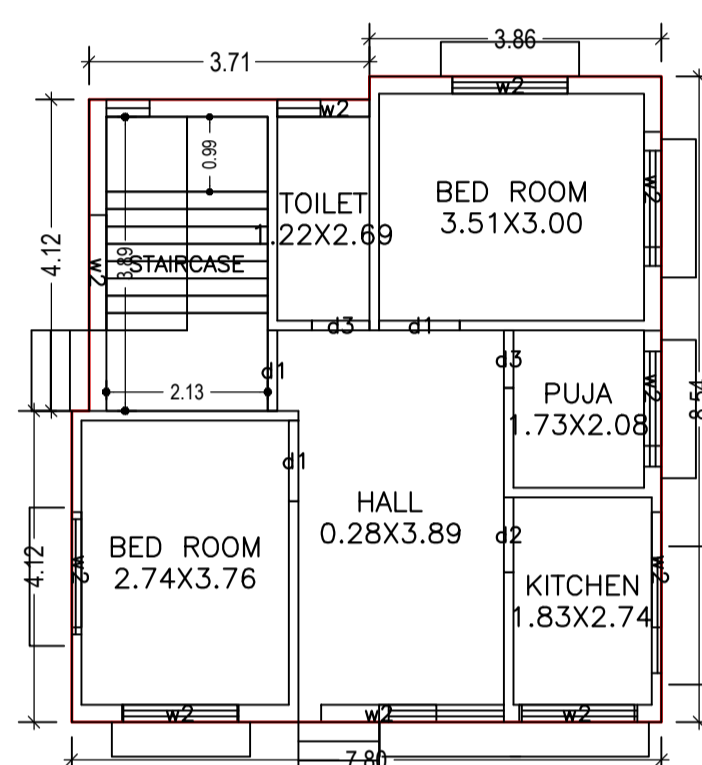

GROUND FLOOR PLAN (Proposed) (SCALE 1:100)

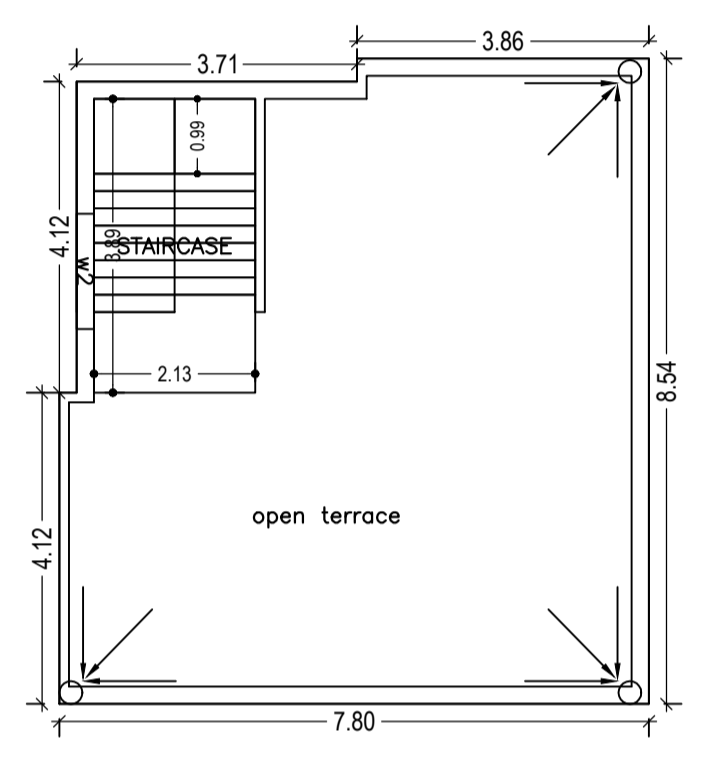

TERRACE FLOOR PLAN (SCALE 1:100)

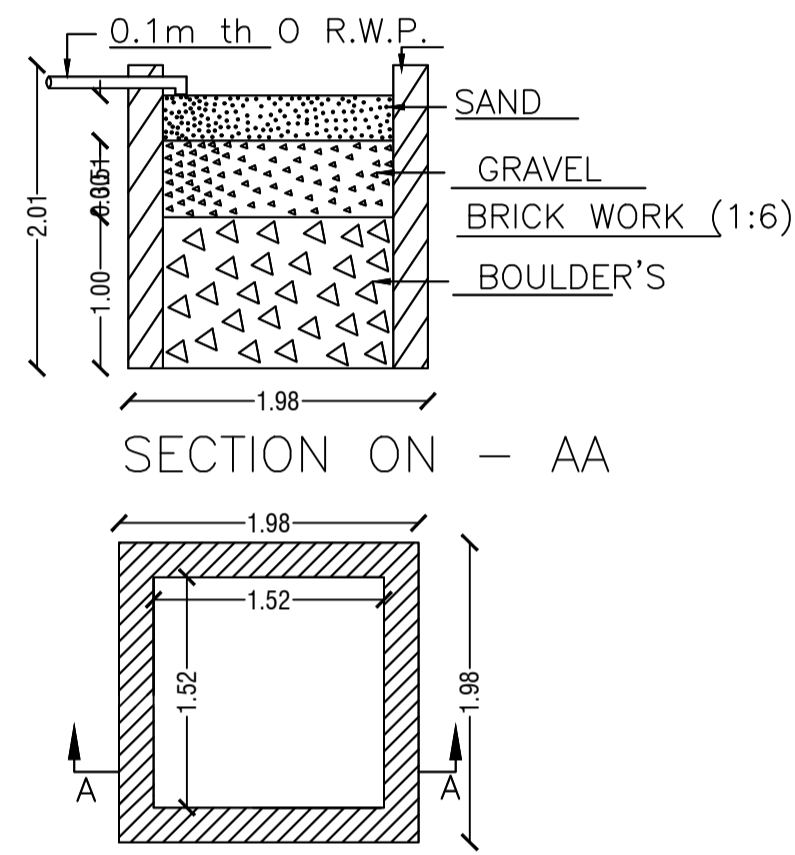

DETAIL'S OF WATER HARVESTING

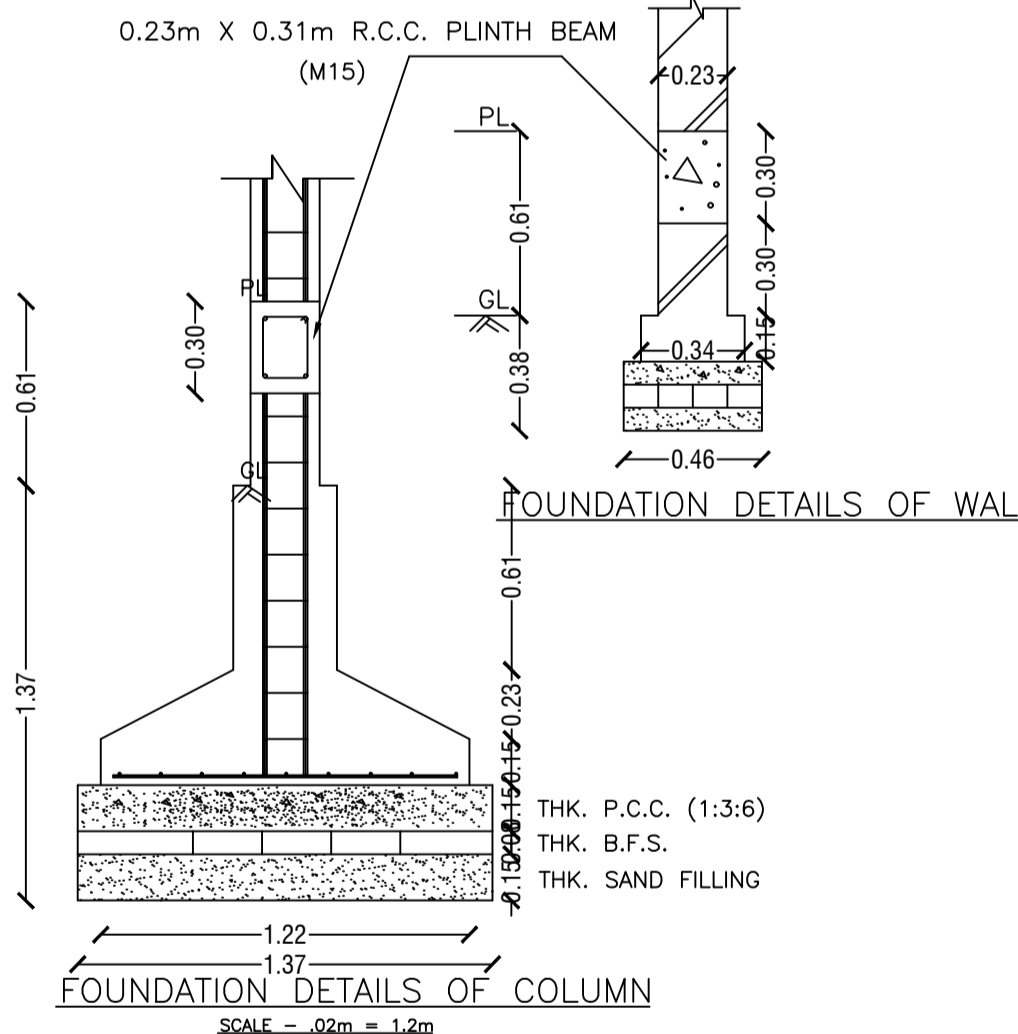

FOUNDATION DETAILS OF WALL

FOUNDATION DETAILS OF COLUMN

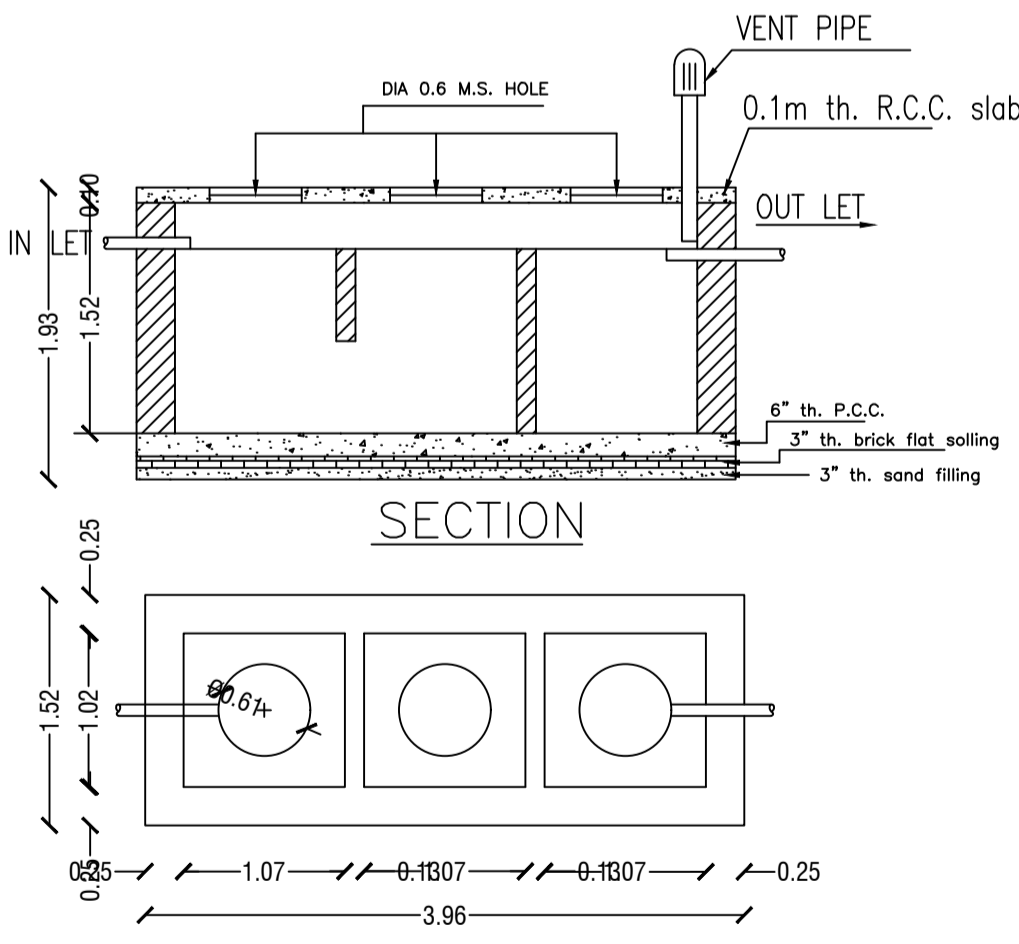

DETAILS OF SEPTIC TANK

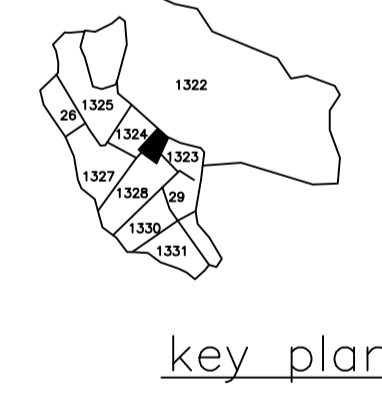

key plan

AREA STATEMENT (DHANBAD MUNICIPAL CORPORATION)		VERSION NO.: 1.0.14
PROJECT DETAIL :		VERSION DATE: 11/07/2017
Region: JHARKHAND URBAN LOCAL BODIES	Plot Use: Residential	
District: DHANBAD	Plot SubUse: Residential Bldg/Apartment	
Authority: DHANBAD MUNICIPAL CORPORATION	PlotNearby/ReligiousStructure: NA	
Inward No: DMC/BP/0051/W23/2017	Plot/SubPlot No: 1323, 1324 & 1328	
Application Type: General Proposal	North: Plot No. - Vendors Niz	
Project Type: Building Permission	South: Plot No. - Ajay Singh, 1328(p)	
Nature of Development: New	East: Road Width - 4.27	
Location of Development Area: Old Area	West: Plot No. - 1324(p)	
AREA DETAILS :		SQ.MT.
AREA OF PLOT (Minimum)	(A)	148.57
NET AREA OF PLOT(Gross Plot Area - Deduction from Gross Plot area)	(A-Deductions)	148.57
Deduction for Balance Plot Area(from Gross Plot Area)		
Common Plot		33.18
Total		33.18
BALANCE AREA OF PLOT(Net Plot Area - Recreational/Amenity space)	(A-Deductions)	115.38
PLOT AREA FOR COVERAGE(Net Plot Area)	(A-Deductions)	148.57
Plot Area for FAR (Net Plot Area + RoadWidening Area)	(A-Deductions)	148.57
COVERAGE CHECK		
Permissible Coverage area ( 70.00 % )		104.00
Proposed Coverage Area ( 43.37 % )		64.44
Total Prop. Coverage area ( 43.37 % )		64.44
Balance coverage area ( 26.63 % )		39.56
FAR CHECK		
Perm. FAR Area ( 1.50 )		222.86
Total Perm. FAR area		222.86
Residential FAR		64.44
Proposed FAR Area		64.44
Total Proposed FAR Area		64.44
Consumed FAR (Factor)		0.43
Balance FAR Area		158.42
BUILT UP AREA CHECK		
Total Proposed BuiltUp Area		64.44
ARCHITECT (Regd)		NISHANT KUMAR
ENGINEER (Regd)		
SUPERVISOR (Regd)		
OWNER (Regd)		Megha Singh
DEVELOPMENT AUTHORITY		LOCAL BODY

COLOR INDEX	
PLOT BOUNDARY	Black
ABUTTING ROAD	Green
PROPOSED CONSTRUCTION	Red
COMMON PLOT	Yellow
ROAD WIDENING AREA	Blue
EXISTING (To be retained)	Orange
EXISTING (To be demolished)	Light Blue

Buildingwise Floor FAR Details				
Floor Name	Building Name		Total	
	Proposed Built Up Area (Sq.mt.)	Proposed FAR Area (Sq.mt.)	Total Proposed Built Up Area (Sq.mt.)	Total FAR Area (Sq.mt.)
Ground Floor	64.44	64.44	64.44	64.44
Terrace Floor	0.00	0.00	0.00	0.00
Total :	64.44	64.44	64.44	64.44

Building USE/SUBUSE Details			
Building Name	Building Use	Building SubUse	Building Structure
A (A)	Residential	Residential Bldg/Apartment	Non-Highrise

FAR & Tenement Details (Table 4c-1)						
Building	No. of Same Bldg	Total Built Up Area (Sq.mt.)	Proposed FAR Area (Sq.mt.)	Total FAR Area (Sq.mt.)	Total Consumed Additional FAR Area (Sq.mt.)	Tnmt (No.)
A (A)	1	64.44	64.44	64.44	64.44	01
Grand Total :	1	64.44	64.44	64.44	64.44	1.00

SCHEDULE OF DOOR:				
BUILDING NAME	NAME	LENGTH	HEIGHT	NOS
A (A)	d3	0.76	2.10	02
A (A)	d2	0.99	2.10	01
A (A)	d1	1.07	2.10	03

SCHEDULE OF WINDOW/VENTILATION:				
BUILDING NAME	NAME	LENGTH	NOS	
A (A)	w2	1.22	1.20	
A (A)	w2	1.52	1.20	10

Building :A (A)					
Floor Name	Total Built Up Area (Sq.mt.)	Proposed FAR Area (Sq.mt.)	Total FAR Area (Sq.mt.)	Total Consumed Additional FAR Area (Sq.mt.)	Tnmt (No.)
Ground Floor	64.44	64.44	64.44	64.44	01
Terrace Floor	0.00	0.00	0.00	0.00	00
Total :	64.44	64.44	64.44	64.44	01
Total Number of Same Buildings	1				
Total :	64.44	64.44	64.44	64.44	01

LTP NAME AND SIGNATURE	STRUCTURAL ENG'S NAME AND SIGNATURE	BUILDER NAME AND SIGNATURE
NISHANT KUMAR DMC/ENG/0006/2016		