

FRONT ELEVATION
SCALE- 1"=8'

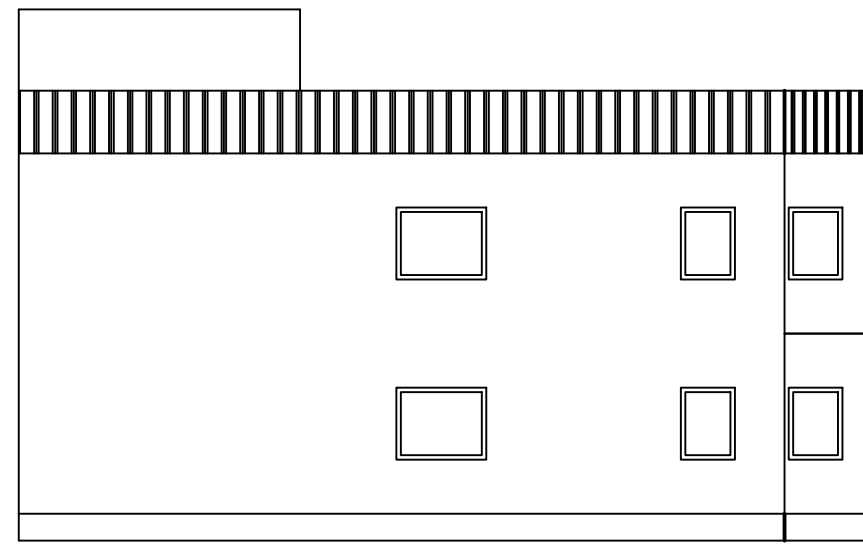

RIGHT SIDE ELEVATION
SCALE- 1"=8'

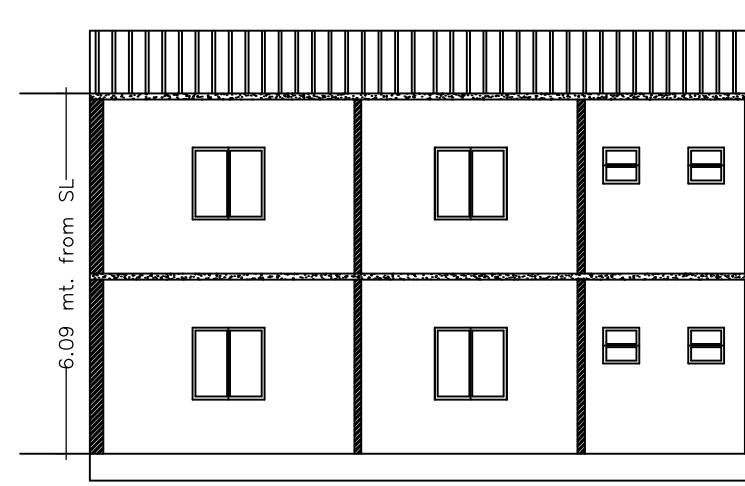

SECTION AT X-X
SCALE- 1"=8'

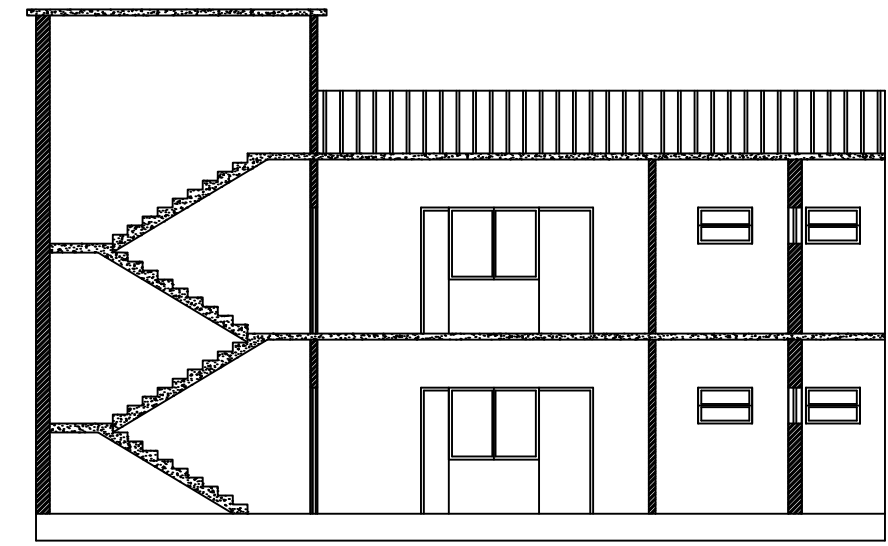

SECTION AT Y-Y
SCALE- 1"=8'

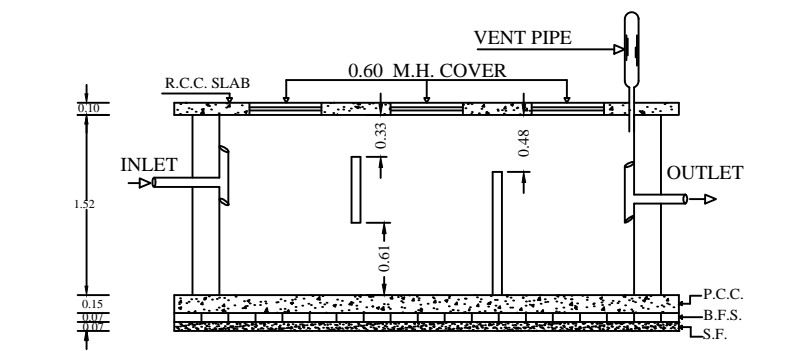

SECTION OF SEPTIC TANK
SCALE:- 1"=4'-0"

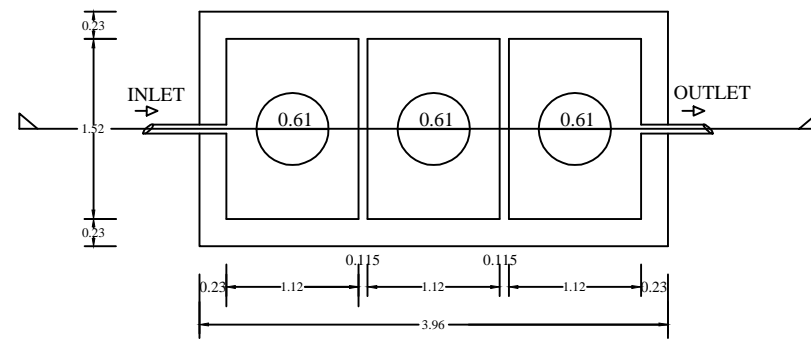

PLAN OF SEPTIC TANK
SCALE:- 1"=4'-0"

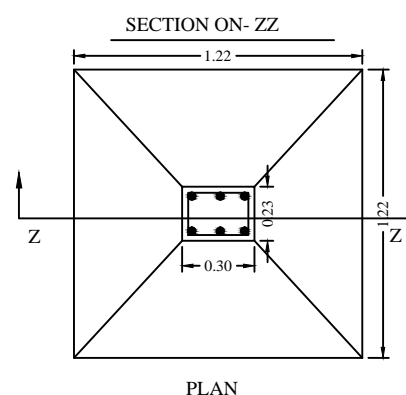
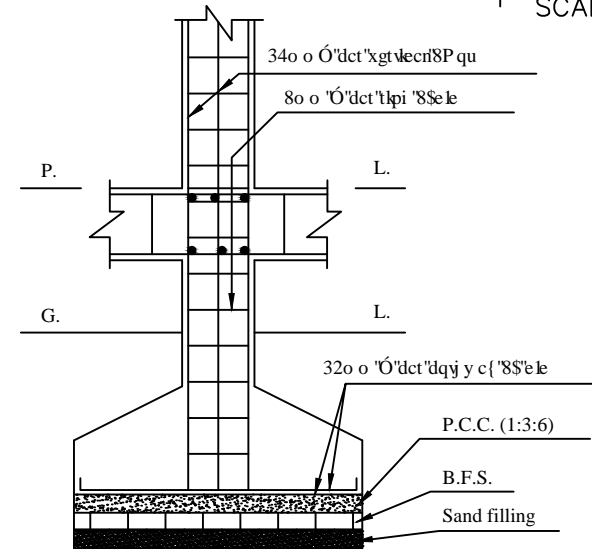

*DETAILS OF COLUMN FOOTING
SCALE :- 1" = 2'-0"

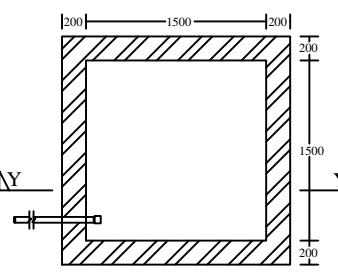
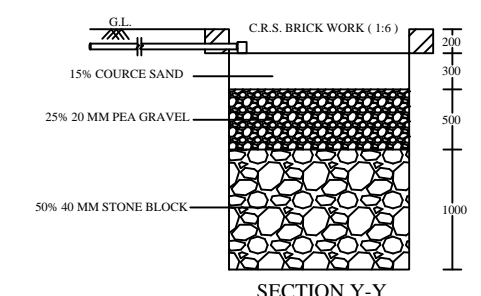
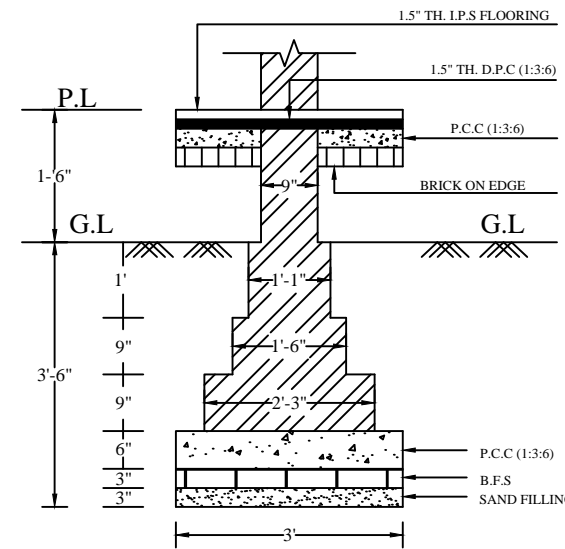

PLAN OF RECHARGE WELL
(WATER HARVESTING)
SCALE:- 1"=4'-0"

BRIEF SPECIFICATION

FOUNDATION :- R.C.C, (1:1½:3) Column footing foundation.
PLINTH :- 12"th R.C.C. (1:1½:3) all round on plinth level.
FLOORING :- 1"th I.P.S flooring over 3"th P.C.C. (1:3:6)
SUPER STRUCTURE :- First class brick work in cement mortar (1:6).
SLAB,BEAM & LINTEL :- All R.C.C. work (1:1½:3).
WOOD WORK :- All door & window frames of sal wood.
PLASTERING :- 0.5"th cement plaster (1:6) both side.

SCHEDULE OF DOORS & WINDOWS

D1 - 1.06 X 2.13	W1 - 1.22 X 1.22
D2 - 0.91 X 2.13	W2 - 0.91 X 1.22
D3 - 0.76 X 2.13	V - 0.61 X 0.46

DETAILS OF AREA

AS PER DEED AREA	-----	265.03 M.
TOTAL PLOT AREA	-----	249.22 M.
GROUND FLOOR AREA	-----	119.46 M.
FIRST FLOOR AREA	-----	119.46 M.
TOTAL COVERED AREA	-----	238.92 M.

TITLE OF DRAWING

PROPOSED A RESIDENTIAL BUILDING OF SMT SHAMIDA KHATOON, W/O- KAJAI RAHMATULLAH OF GAJATAND, :- P.S-- DHANSAR, DIST- DHANBAD UNDER MAUZA-MANAITAND MOUZA NO-50, UNDER KHATA NO.- 53, PLOT NO. -119, (PART) AREA - 1440-SQFT OR TO SAY 3.30 2 DECIMAL.
 (2ND PART)
 LAND OF VILLAGE MANAITAND MOUZA NO-50 THANA(DHANBAD) JHARIA DHN LAN WITH HOUSE WELL ETC OLD BY-SMT:-ANUPAMA SINHA CHOUDHARI(2)SHUSHILA SINHA CHOUDHARI (3) ANJAN SINHA CHOUDHARI OF GAJATAND(MANAITAND) TO SMI SAMIDA KHATOON OR RAHMATULLAH OF MANAITAND DHANBAD, MOUZA -MANAITAND MOUZA NO:- 50.KHATA NO:-53. PLOT NO:-119 AREA 6 KATHAS 4352 SQFT MEGIRIN OF PART 2 KATHAS
 D I S T - D H A N B A D ,
 S T A T E - J H A R K H A N D .

SIG. OF OWNER

SIG. OF ENGINEER

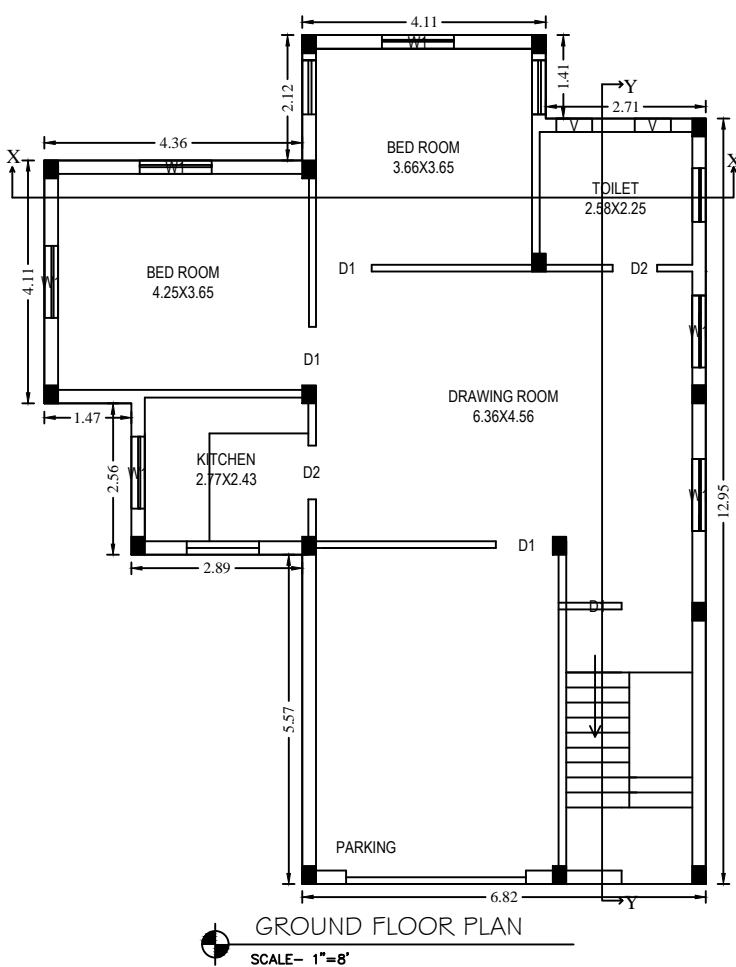

GROUND FLOOR PLAN
SCALE- 1"=8'

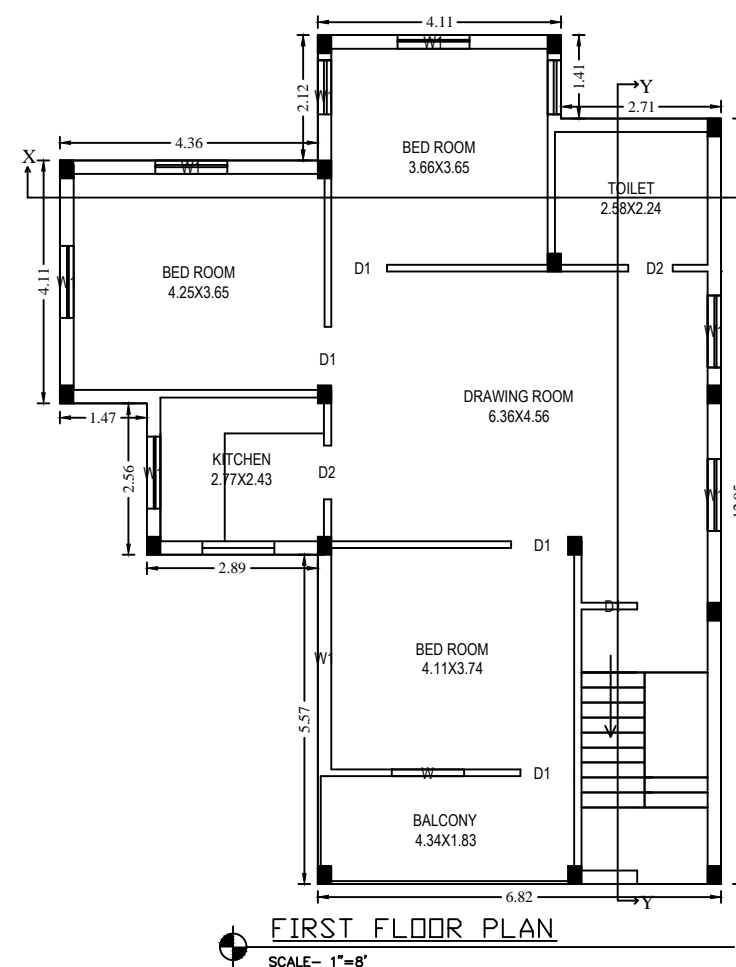

FIRST FLOOR PLAN
SCALE- 1"=8'

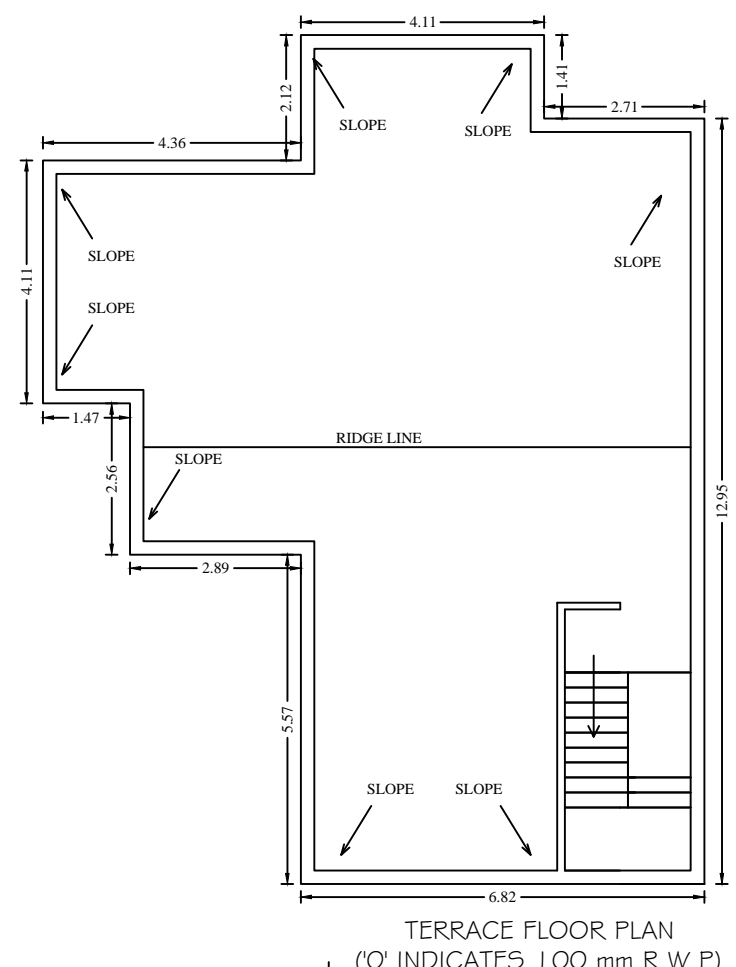

TERRACE FLOOR PLAN
(O' INDICATES 100 mm R.W.P)
SCALE- 1"=8'

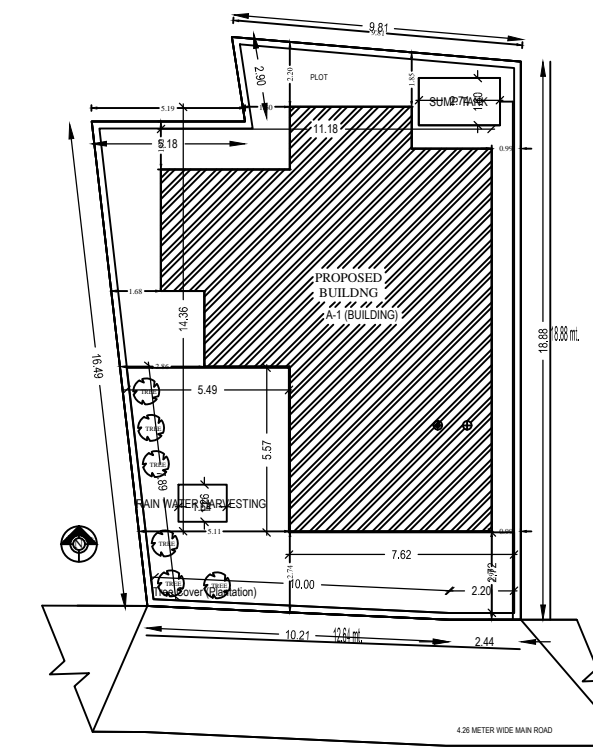

SITE PLAN
SCALE- 1"=16'