

Building USE/SUBUSE Details

Building Name	Building Use	Building SubUse	Building Structure
A (B)	Residential	Bungalow/ Dwelling / Non Apartment	Non-Highrise

Building :A (B)

Floor Name	Total Built Up Area (Sq.mt.)	Proposed FAR Area (Sq.mt.)	Total FAR Area (Sq.mt.)	Total Consumed Additional FAR Area (Sq.mt.)	Tnmt (No.)
Basement Floor	93.98	93.98	93.98	93.98	01
Ground Floor	93.98	93.98	93.98	93.98	00
First Floor	93.98	93.98	93.98	93.98	00
Second Floor	93.98	93.98	93.98	93.98	00
Terrace Floor	0.00	0.00	0.00	0.00	00
Total :	375.92	375.92	375.92	375.92	01
Total Number of Same Buildings	1				
Total :	375.92	375.92	375.92	375.92	01

SCHEDULE OF DOOR:

BUILDING NAME	NAME	LENGTH	HEIGHT	NOS
A (B)	D	0.76	2.10	03
A (B)	D1	0.90	2.10	03
A (B)	D2	0.99	2.10	06
A (B)	D3	1.30	2.10	04

SCHEDULE OF WINDOW/VENTILATION:

BUILDING NAME	NAME	LENGTH	HEIGHT	NOS
A (B)	V	0.60	0.60	03
A (B)	W	0.90	1.20	07
A (B)	W1	1.00	1.20	18

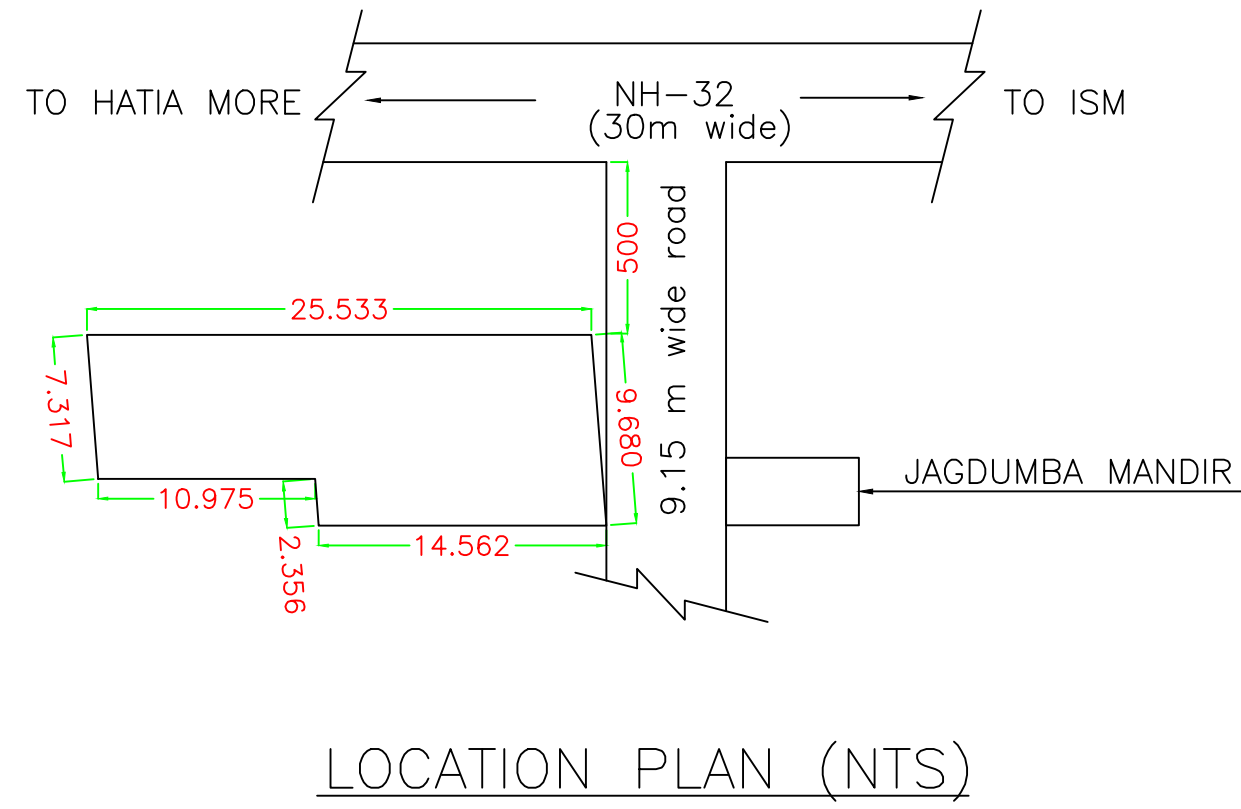
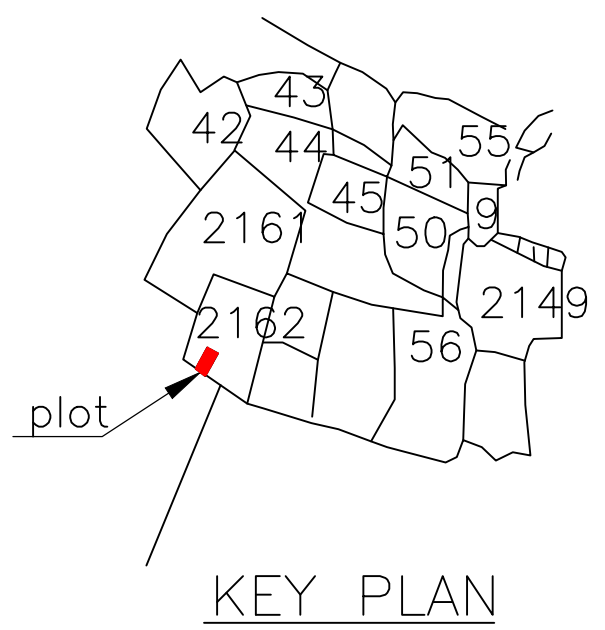

Proposal Basic Information

Proposal File No.	DMC/BP/0070/W25/2017
Owner Name	Mukesh Kumar Sinha
Khata No	Municipal Khata
Plot No	2162
Village Name	Hirapur
Use	Residential
SubUse	Boarding

AREA STATEMENT
DHANBAD MUNICIPAL CORPORATION
VERSION NO.: 1.0.29
VERSION DATE: 30/06/2018

AREA DETAILS:		SQ.MT.
AREA OF PLOT (Minimum)	(A)	220.54
NET AREA OF PLOT (Gross Plot Area - Deduction from Gross Plot area)	(A-Deductions)	220.54
Deduction for Balance Plot Area (from Gross Plot Area)		
Common Plot		25.28
Total		25.28
BALANCE AREA OF PLOT (Net Plot Area - Recreational/Amenity space)	(A-Deductions)	195.26
PLOT AREA FOR COVERAGE (Net Plot Area)	(A-Deductions)	220.54
Plot Area for FAR (Net Plot Area + Road Widening Area)	(A-Deductions)	220.54
COVERAGE CHECK		
Permissible Coverage area (70.00 %)		154.38
Proposed Coverage Area (42.61 %)		93.98
Total Prop. Coverage Area (42.61 %)		93.98
Balance coverage area (27.39 %)		60.40
FAR CHECK		
Perm. FAR Area (2.50)		551.35
Total Perm. FAR area		551.35
Residential FAR		375.93
Proposed FAR Area		375.93
Total Proposed FAR Area		375.93
Consumed FAR (Factor)		1.70
Balance FAR Area		175.42
BUILT UP AREA CHECK		
Total Proposed Built Up Area		375.92
ARCHITECT (Regd)	Ajit Kumar	
ENGINEER (Regd)		
SUPERVISOR (Regd)		
OWNER (Regd)	Mukesh Kumar Sinha	
DEVELOPMENT AUTHORITY		LOCAL BODY

COLOR INDEX

PLOT BOUNDARY	Black
ABUTTING ROAD	Green
PROPOSED CONSTRUCTION	Red
COMMON PLOT	Yellow
ROAD WIDENING AREA	Blue
EXISTING (To be retained)	Orange
EXISTING (To be demolished)	Grey

Buildingwise Floor FAR Details

Floor Name	Building Name A (B)		Total	
	Proposed Built Up Area (Sq.mt.)	Proposed FAR Area (Sq.mt.)	Total Proposed Built Up Area (Sq.mt.)	Total FAR Area (Sq.mt.)
Basement Floor	93.98	93.98	93.98	93.98
Ground Floor	93.98	93.98	93.98	93.98
First Floor	93.98	93.98	93.98	93.98
Second Floor	93.98	93.98	93.98	93.98
Terrace Floor	0.00	0.00	0.00	0.00
Total :	375.92	375.92	375.92	375.92

UnitBUA Table for Building :A (B)

FLOOR	Name	UnitBUA Type	UnitBUA Area	Carpet Area	No. of Rooms	No. of Tenement
GROUND FLOOR PLAN	SPLIT A	FLAT	0.00	0.00	5	0
TYPICAL - 1st & 2 FLOOR PLAN	SPLIT A	FLAT	0.00	0.00	5	0
BASEMENT FLOOR PLAN	SPLIT A	FLAT	375.93	375.61	1	1
Total:	-	-	375.93	375.61	16	1

FAR & Tenement Details (Table 4c-1)

Building	No. of Same Bldg	Total Built Up Area (Sq.mt.)	Proposed FAR Area (Sq.mt.)	Total FAR Area (Sq.mt.)	Total Consumed Additional FAR Area (Sq.mt.)	Tnmt (No.)
A (B)	1	375.92	375.92	375.92	375.92	01
Grand Total :	1	375.92	375.92	375.92	375.92	01

LTP NAME AND SIGNATURE	STRUCTURAL ENG'S NAME AND SIGNATURE	BUILDER NAME AND SIGNATURE
Ajit Kumar DMC/ENG/0014/2016		

Proposal Basic Information	
Proposal File No.	DMC/BP/0070/W25/2017
Owner Name	Mukesh Kumar Sinha
Khata No	Municipal Khata
Plot No	2162
Village Name	Hirapur
Use	Residential
SubUse	Boarding

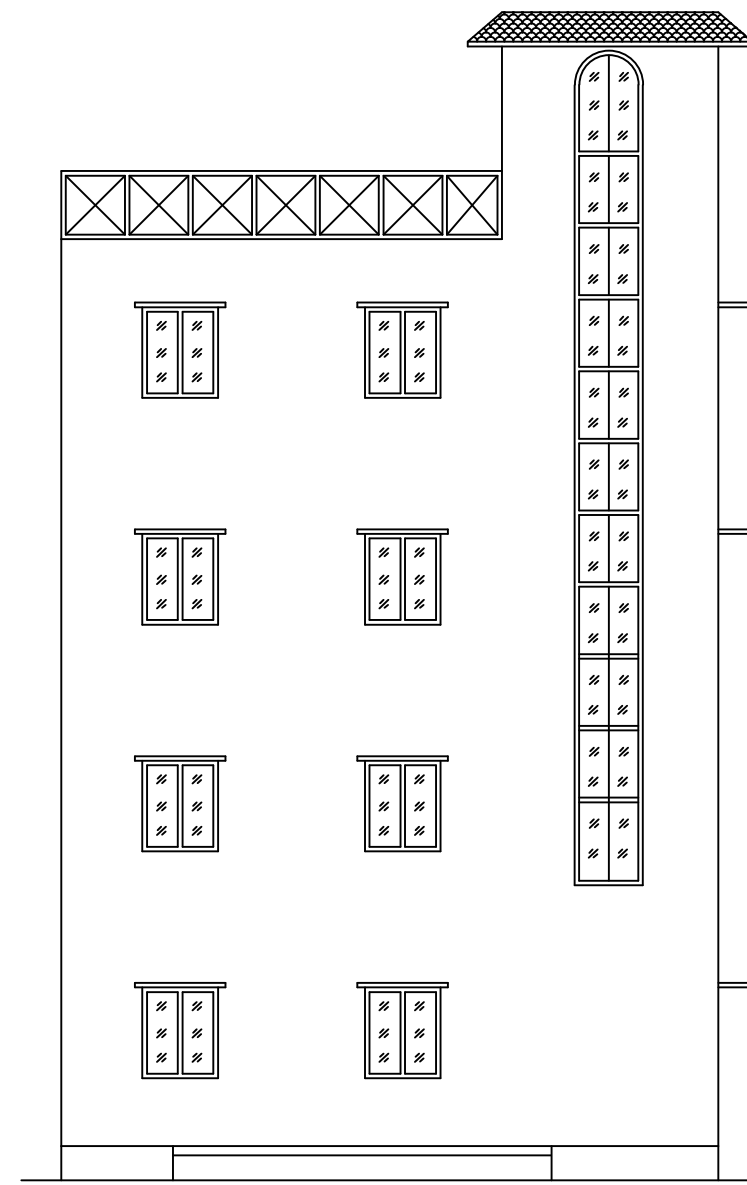

FRONT ELEVATION

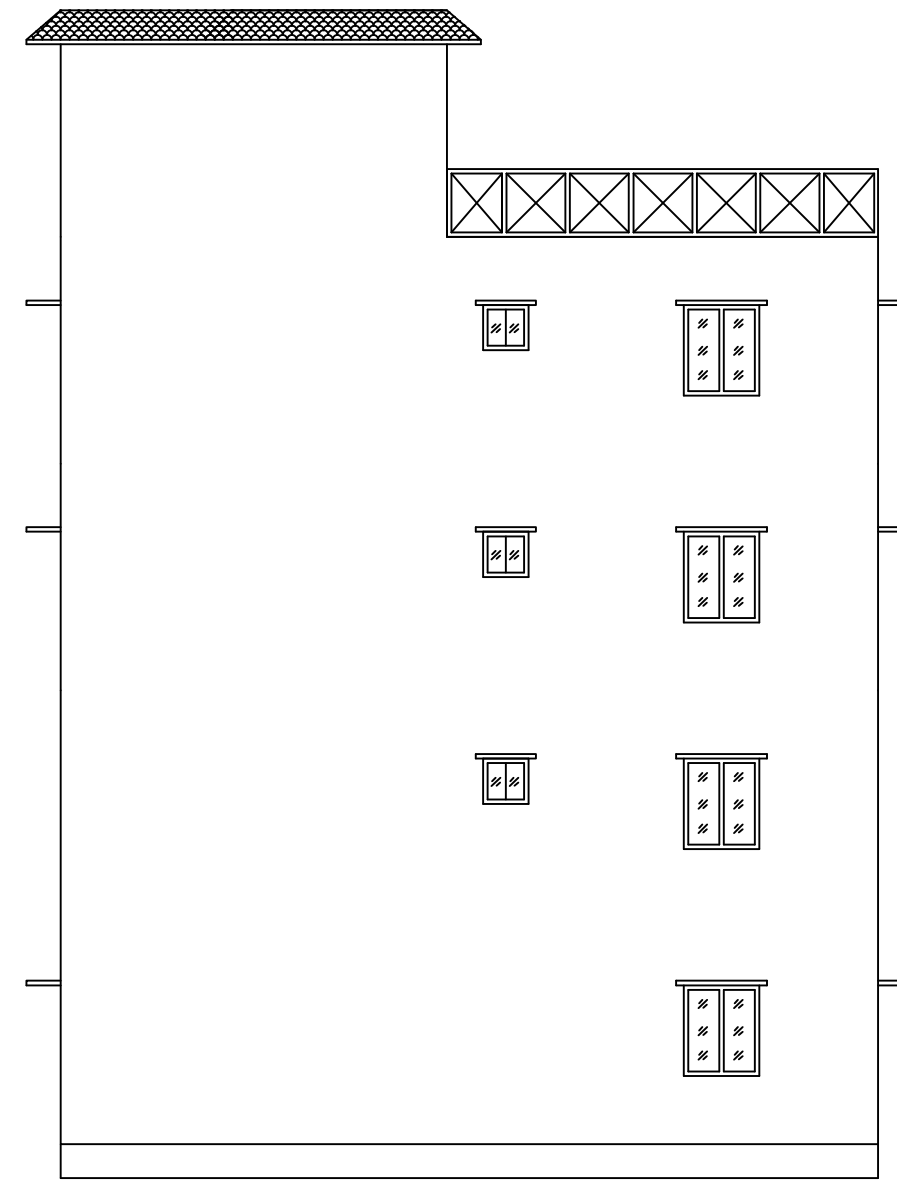

RIGHT SIDE ELEVATION

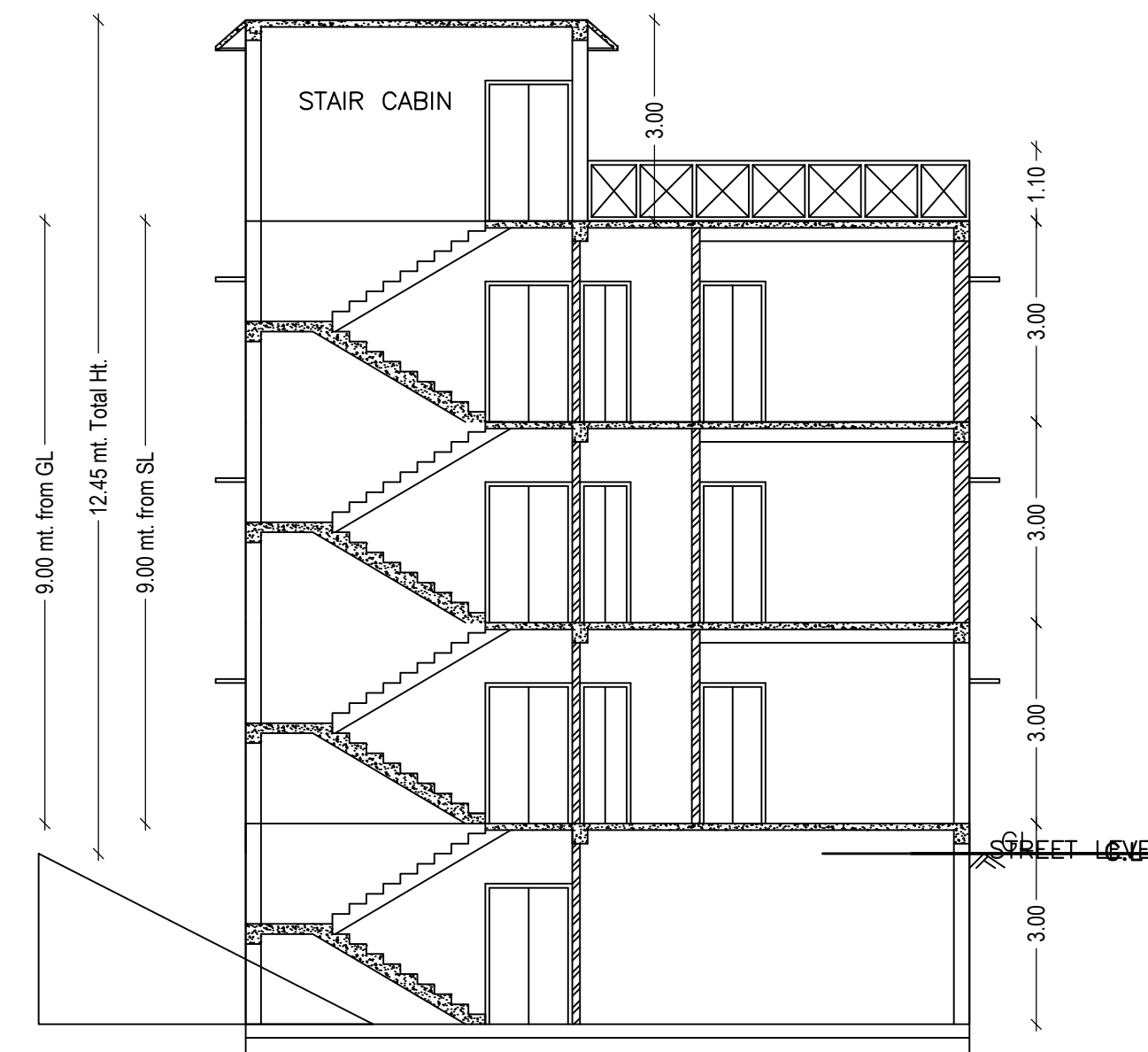

SECTION AT Y-Y

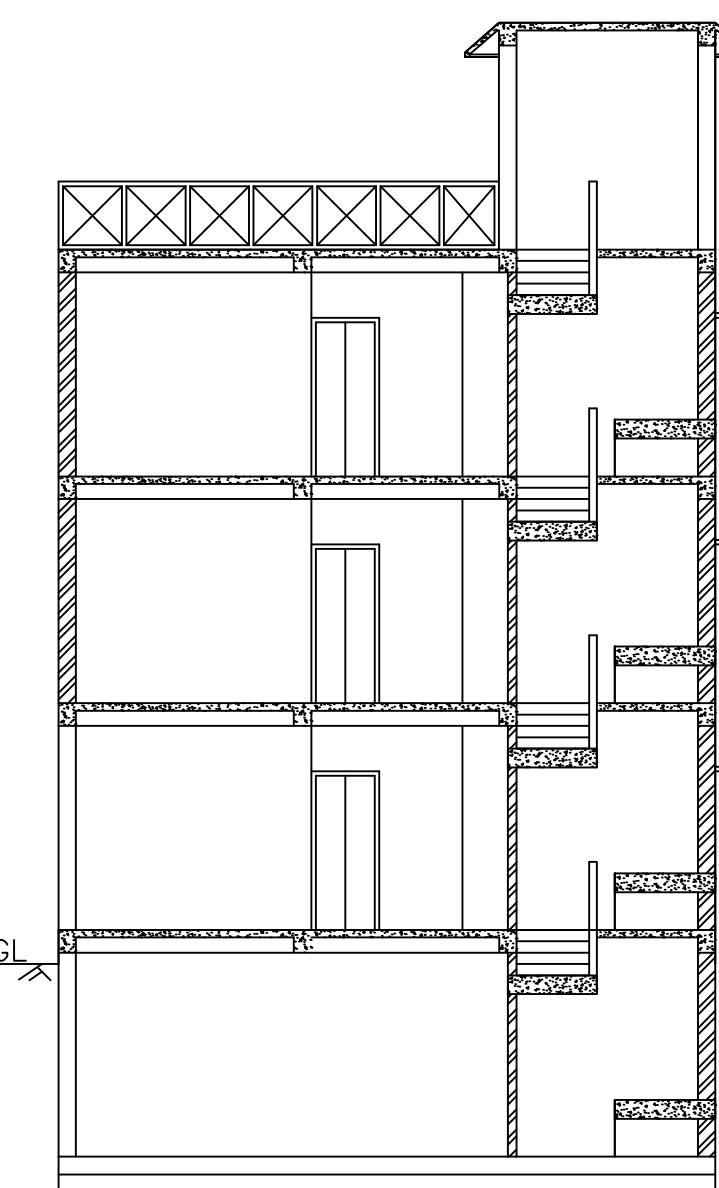

SECTION AT X-X

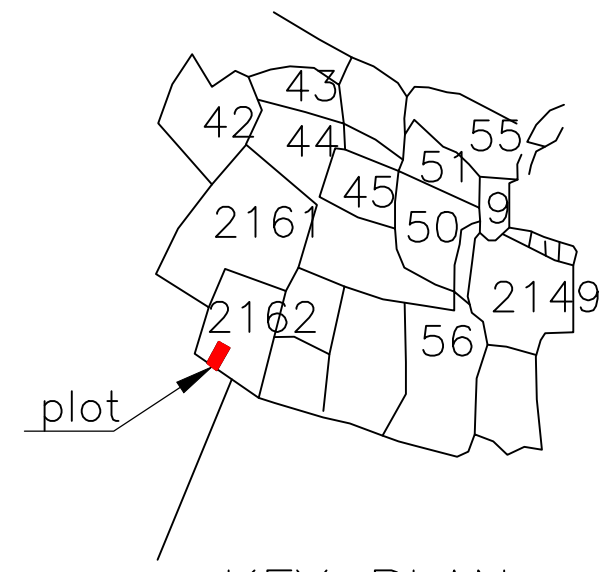

KEY PLAN

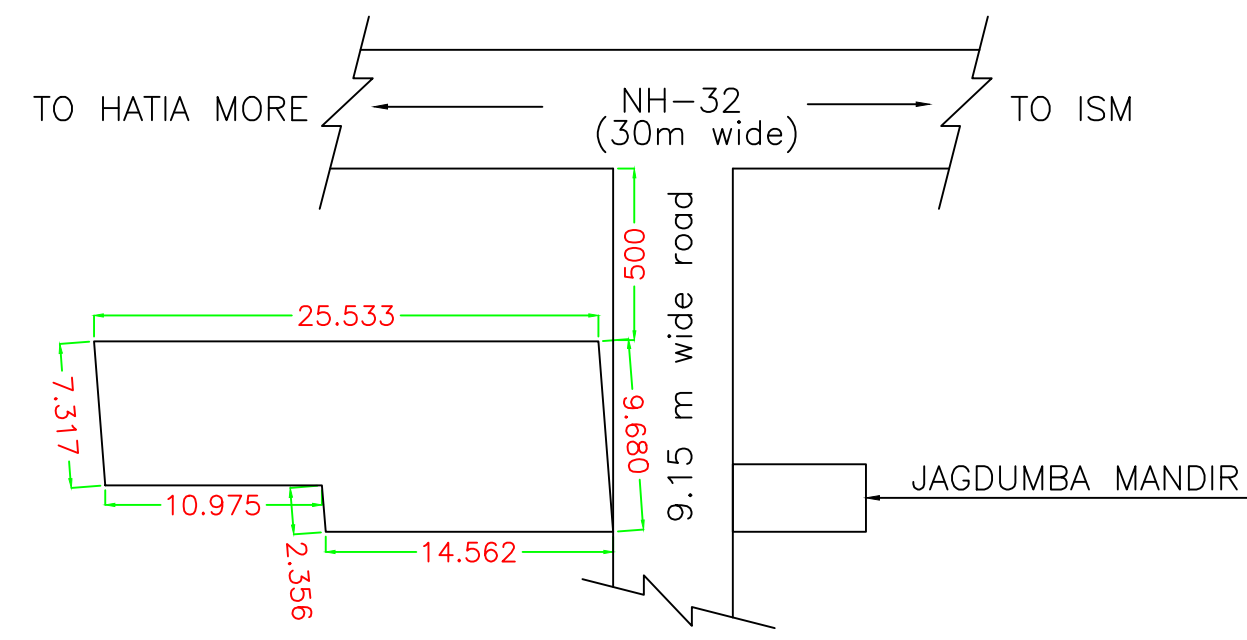

LOCATION PLAN (NTS)

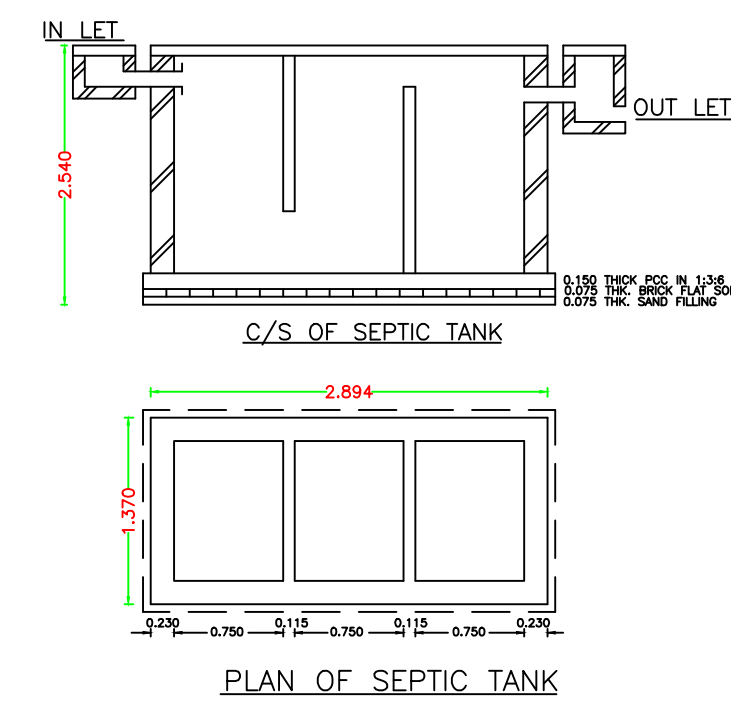

PLAN OF SEPTIC TANK

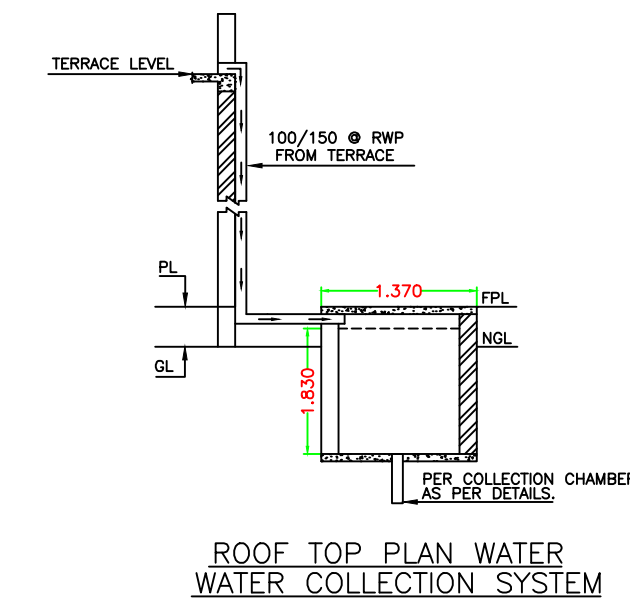

ROOF TOP PLAN WATER COLLECTION SYSTEM

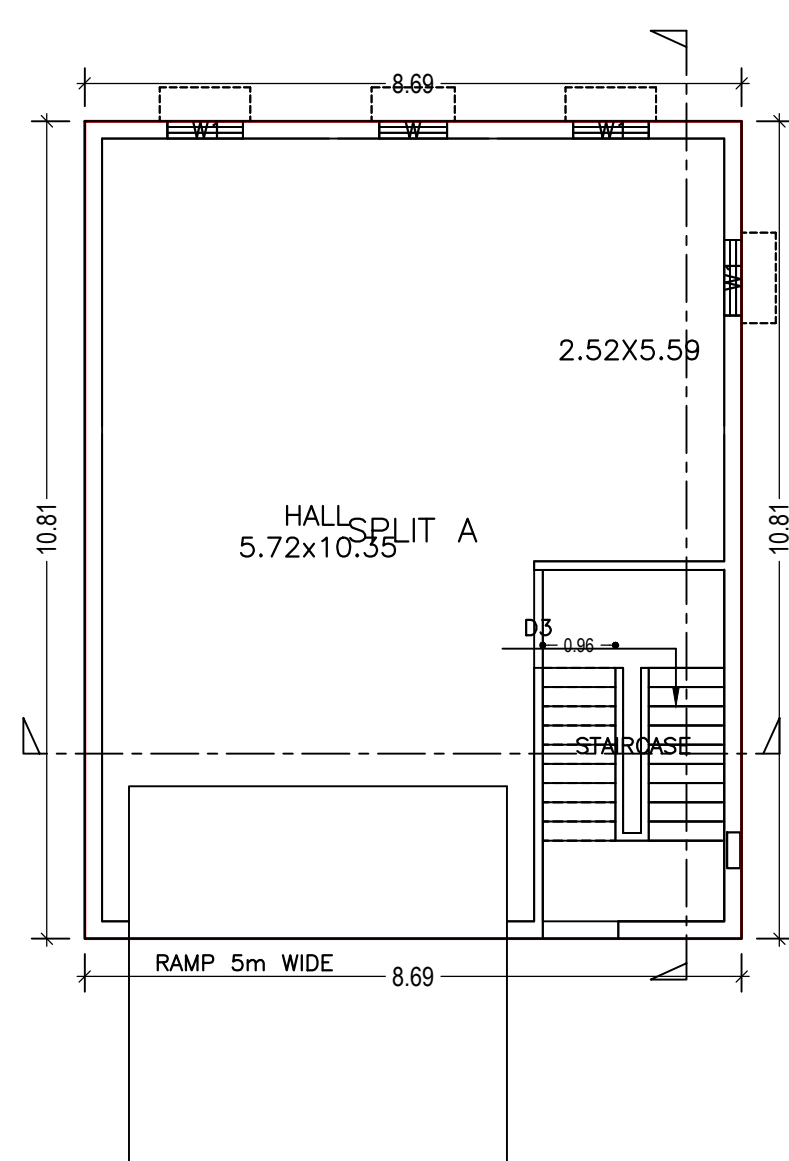

BASEMENT FLOOR PLAN (Proposed) (SCALE 1:100)

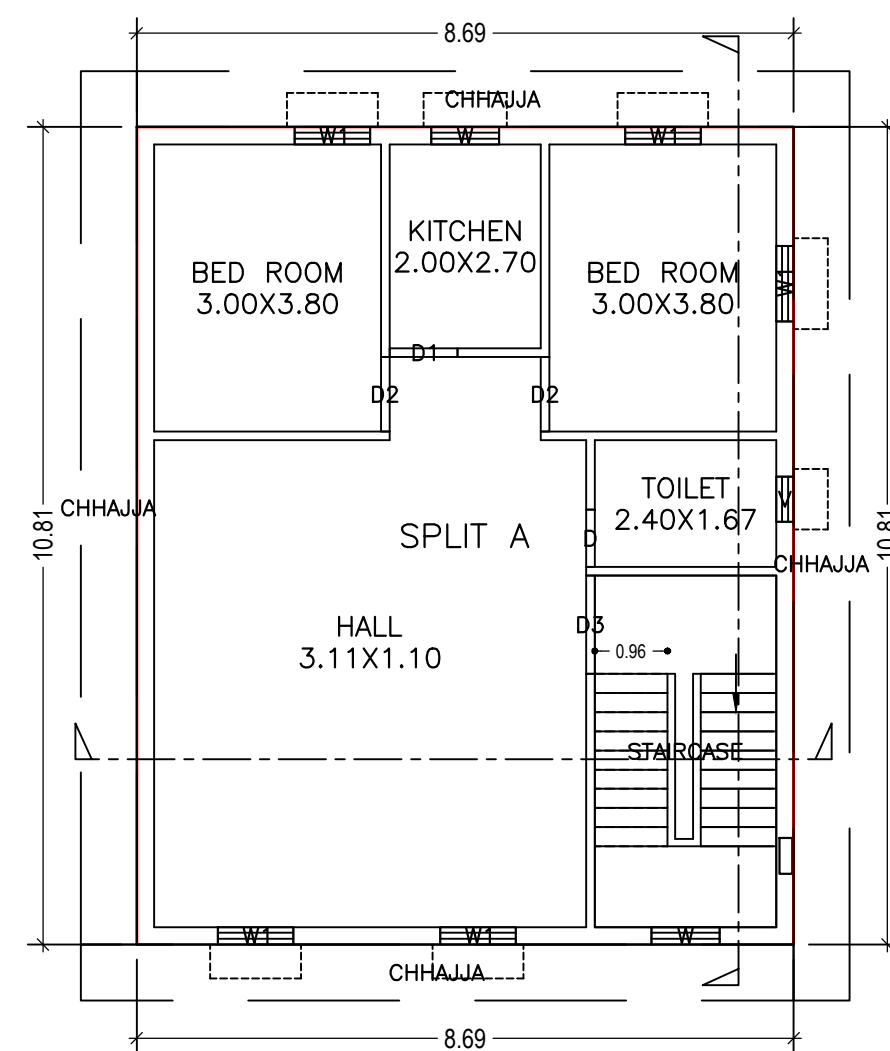

TYPICAL - 1 & 2 FLOOR PLAN (Proposed) (SCALE 1:100)

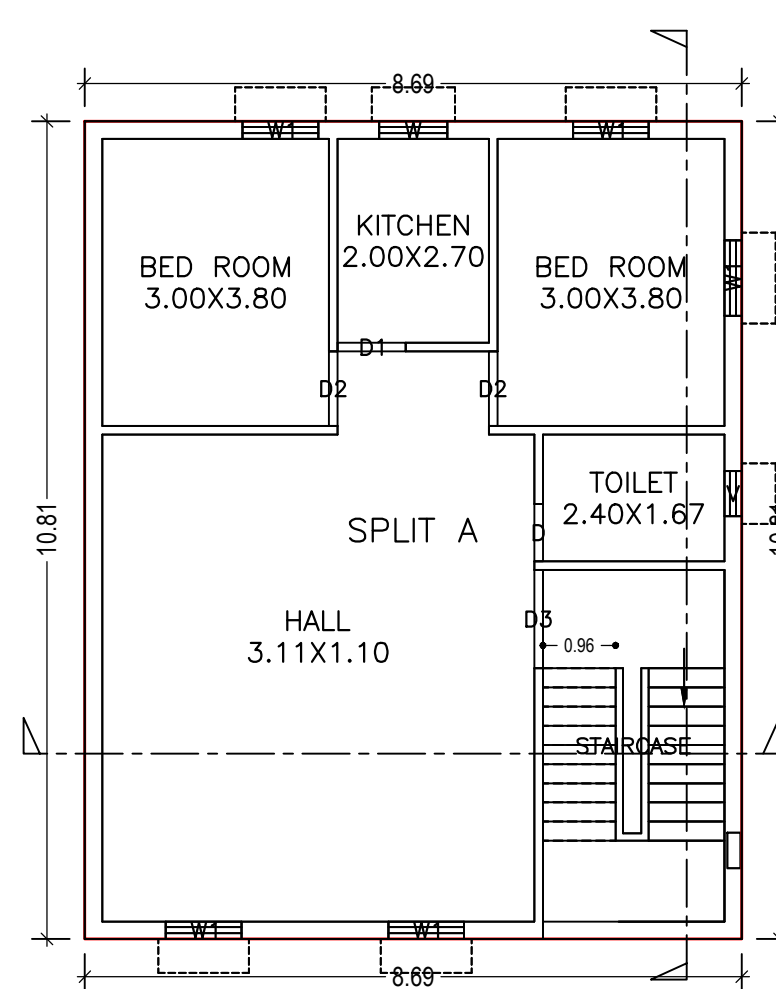

GROUND FLOOR PLAN (Proposed) (SCALE 1:100)

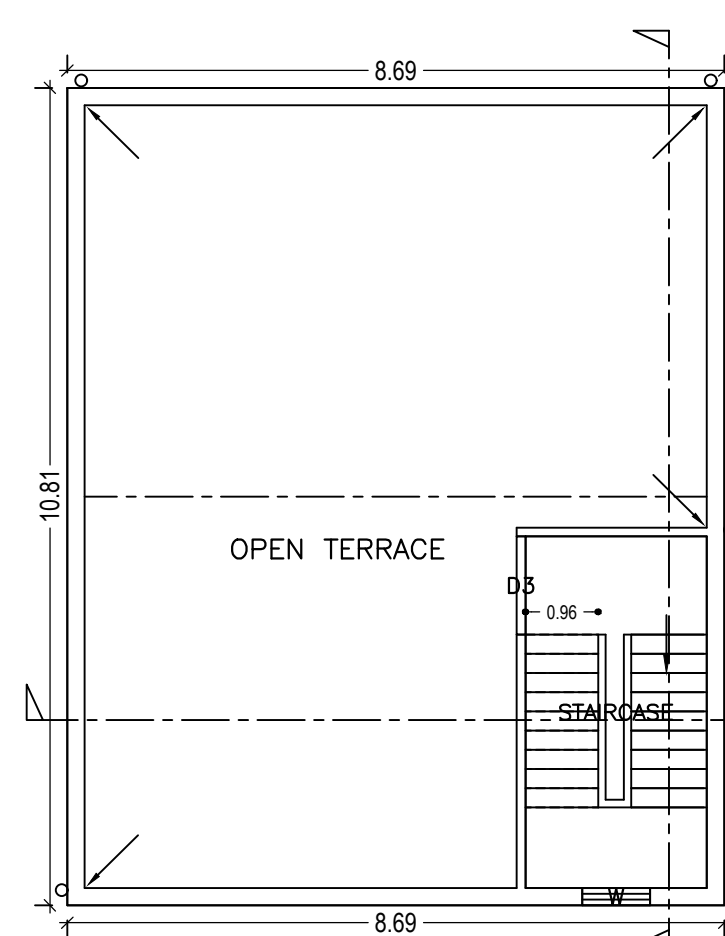

TERRACE FLOOR PLAN (SCALE 1:100)

LTP NAME AND SIGNATURE	STRUCTURAL ENG'S NAME AND SIGNATURE	BUILDER NAME AND SIGNATURE
Ajit Kumar DMC/ENG/0014/2016		