

Proposal Basic Information	
Proposal File No.	DMC/BI/0148/W22/2017
Owner Name	SRI SHIV LAL RAM
Khata No	11
Plot No	148
Village Name	Bhelaland
Use	Residential
SubUse	Boarding

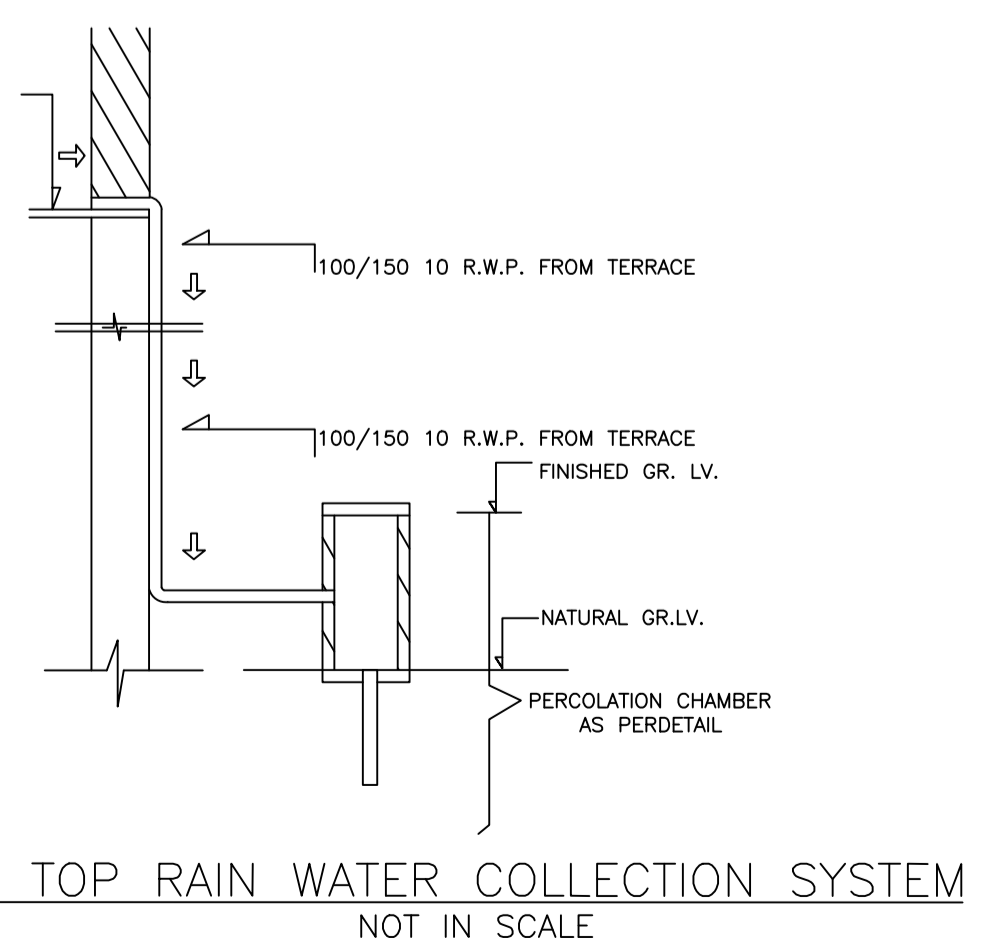
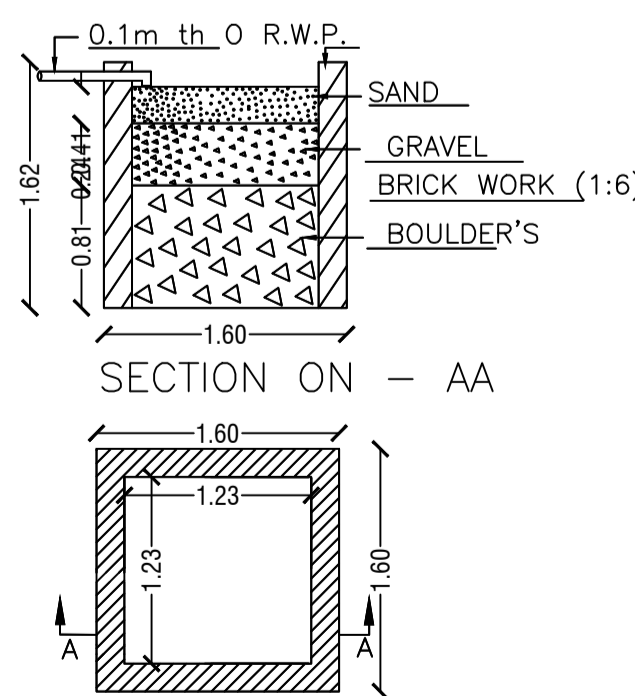
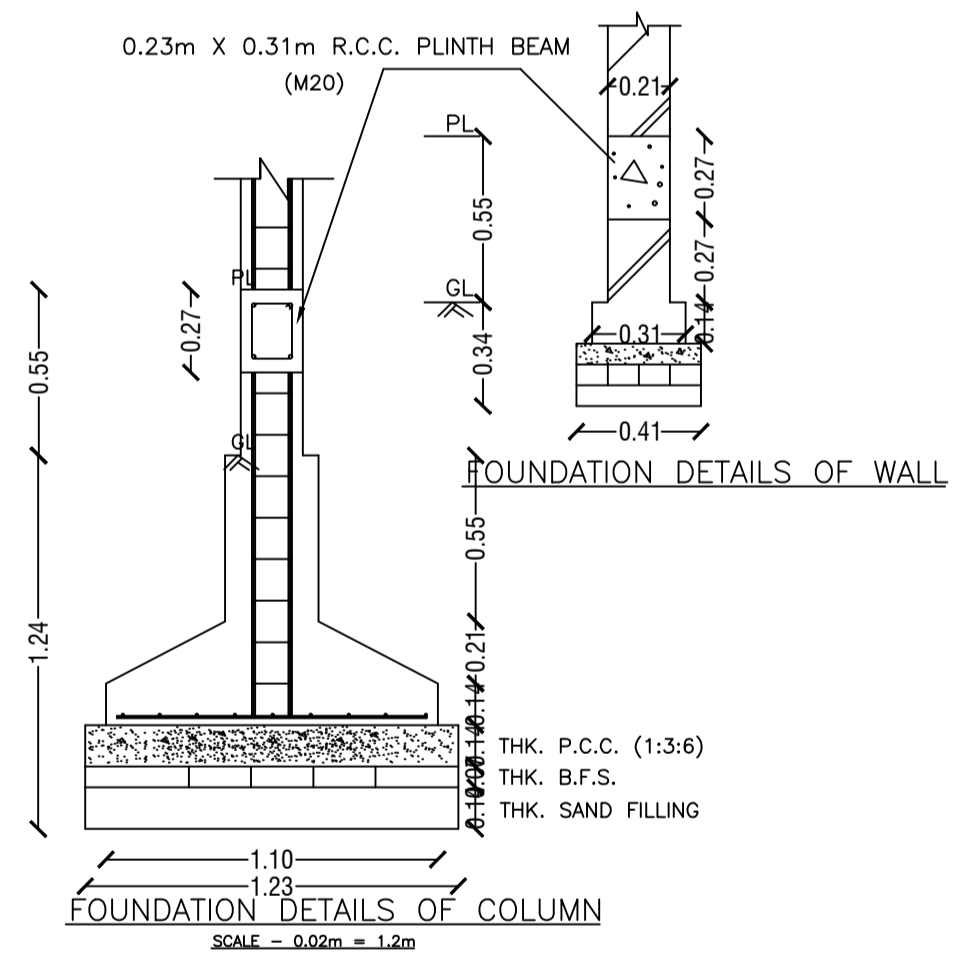
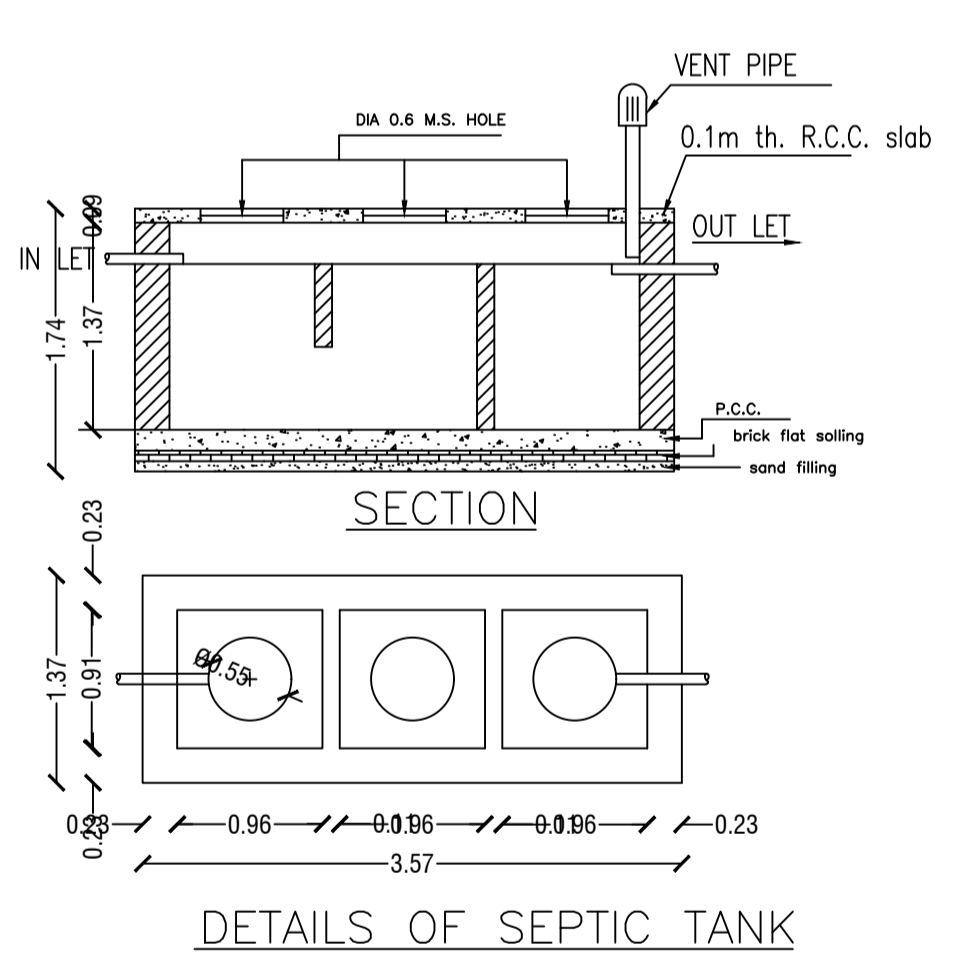
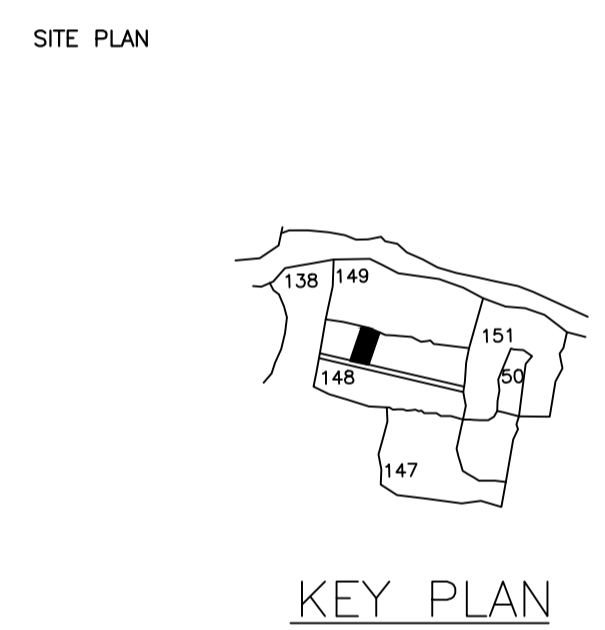
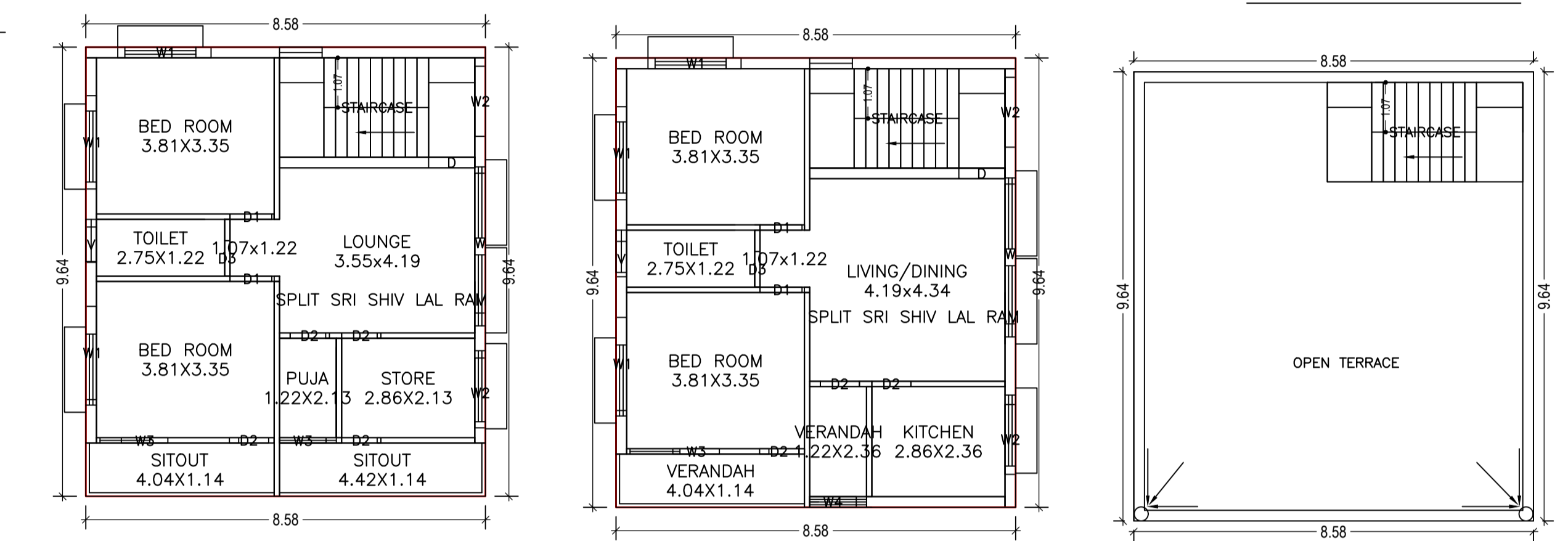
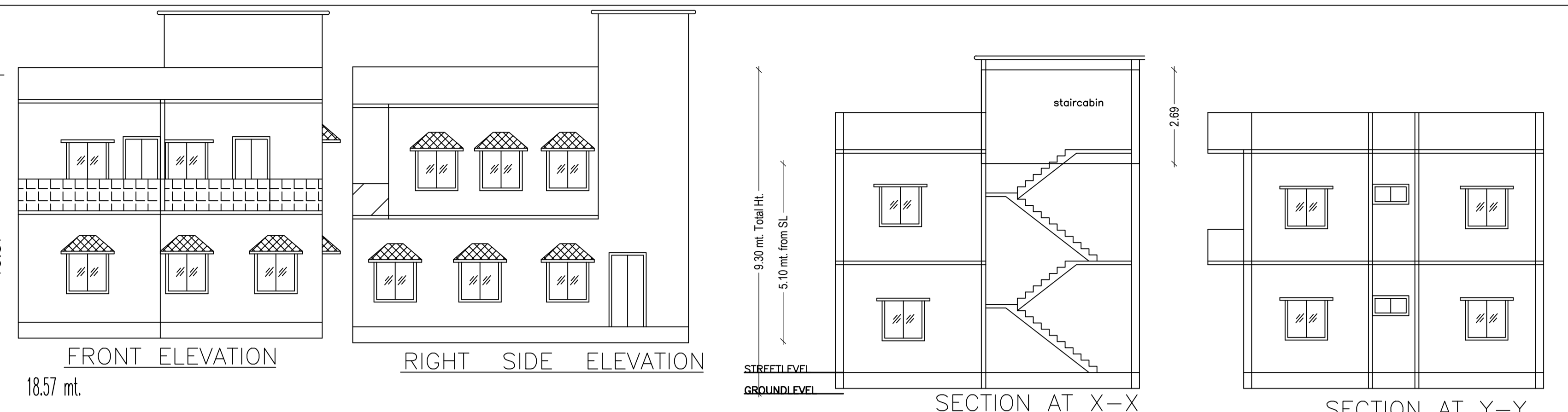
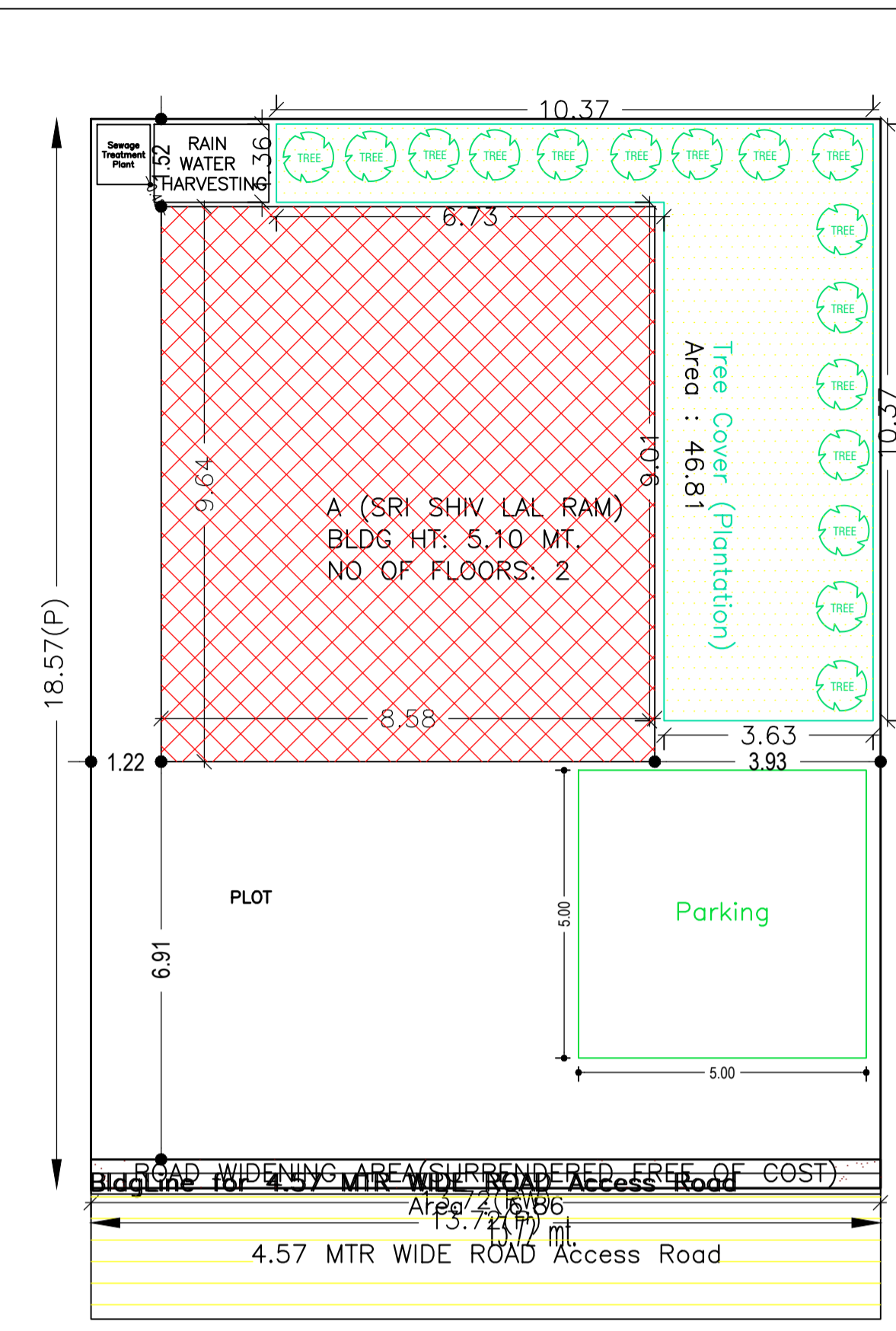

**SCHEDULE OF DOOR:**

BUILDING NAME	NAME	LENGTH	HEIGHT	NOS
A (SRI SHIV LAL RAM)	D3	0.76	2.13	02
A (SRI SHIV LAL RAM)	D2	0.84	2.13	07
A (SRI SHIV LAL RAM)	D1	0.90	2.13	04
A (SRI SHIV LAL RAM)	D	0.99	2.13	02

**SCHEDULE OF WINDOW/VENTILATION:**

BUILDING NAME	NAME	LENGTH	HEIGHT	NOS
A (SRI SHIV LAL RAM)	V	0.76	1.00	02
A (SRI SHIV LAL RAM)	W3	1.00	2.50	03
A (SRI SHIV LAL RAM)	W4	1.00	2.50	01
A (SRI SHIV LAL RAM)	W2	1.50	2.50	04
A (SRI SHIV LAL RAM)	W1	2.00	2.50	06
A (SRI SHIV LAL RAM)	W	3.00	2.50	02

**Building USE/SUBUSE Details**

Building Name	Building Use	Building SubUse	Building Structure
A (SRI SHIV LAL RAM)	Residential	Residential Bldg/Apartment	Non-Highrise

**UnitBUA Table for Building :A (SRI SHIV LAL RAM)**

FLOOR	Name	UnitBUA Type	UnitBUA Area	Carpet Area	No. of Rooms	No. of Tenement
FIRST FLOOR PLAN	SPLIT SRI SHIV LAL RAM	FLAT	0.00	0.00	8	0
GROUND FLOOR PLAN	SPLIT SRI SHIV LAL RAM	FLAT	132.31	126.91	7	1
Total:	-	-	132.31	126.91	15	1

**FAR & Tenement Details (Table 4c-1)**

Building	No. of Same Bldg	Total Built Up Area (Sq.mt.)	Proposed FAR Area (Sq.mt.)	Total FAR Area (Sq.mt.)	Total Consumed Additional FAR Area (Sq.mt.)	Tnmt (No.)
A (SRI SHIV LAL RAM)	1	165.40	165.40	165.40	165.40	01
Grand Total :	1	165.40	165.40	165.40	165.40	01

**AREA STATEMENT**  
DHANBAD MUNICIPAL CORPORATION

VERSION NO.: 1.0.27  
VERSION DATE: 18/05/2018

**PROJECT DETAIL:**

Region: JHARKHAND URBAN LOCAL BODIES	Plot Use: Residential
District: DHANBAD	Plot SubUse: Boarding
Authority: DHANBAD MUNICIPAL CORPORATION	PlotNearby/ReligiousStructure: NA
Inward No: DMC/BI/0148/W22/2017	Plot/SubPlot No: 148
Application Type: General Proposal	North: Plot No. - 149
Project Type: Building Permission	South: Road Width - 4.25
Nature of Development: New	East: Plot No. - LOT NO. C
Location of Development Area: Old Area	West: Plot No. - LOT NO. A

**AREA DETAILS:**

AREA OF PLOT (Minimum)	(A)	SQ.MT.
Deduction for NetPlot Area		254.81
Surrender Free of Cost		6.86
Total		6.86
NET AREA OF PLOT(Gross Plot Area - Deduction from Gross Plot area)	(A-Deductions)	247.95
Deduction for Balance Plot Area(from Gross Plot Area)		
Surrender Free of Cost		6.86
Common Plot		53.67
Total		53.67
BALANCE AREA OF PLOT(Net Plot Area - Recreational/Amenity space)	(A-Deductions)	201.14
PLOT AREA FOR COVERAGE(Net Plot Area)	(A-Deductions)	247.95
Plot Area for FAR (Net Plot Area + RoadWidening Area)	(A-Deductions)	254.81

**COVERAGE CHECK**

Permissible Coverage area ( 60.00 % )	148.77
Proposed Coverage Area ( 33.35 % )	82.70
Total Prop. Coverage Area ( 33.35 % )	82.70
Balance coverage area ( 26.65 % )	66.07

**FAR CHECK**

Perm. FAR Area ( 1.50 )	382.22
Total Perm. FAR area	382.22
Residential FAR	165.39
Proposed FAR Area	165.39
Total Proposed FAR Area	165.39
Consumed FAR (Factor)	0.65
Balance FAR Area	216.83

**BUILT UP AREA CHECK**

Total Proposed BuiltUp Area	165.40
ARCHITECT (Regd)	KUMARI RINKU RANI
ENGINEER (Regd)	
SUPERVISOR (Regd)	
OWNER (Regd)	SRI SHIV LAL RAM
DEVELOPMENT AUTHORITY	LOCAL BODY

**COLOR INDEX**

PLOT BOUNDARY	Black
ABUTTING ROAD	Green
PROPOSED CONSTRUCTION	Red
COMMON PLOT	Yellow
ROAD WIDENING AREA	Blue
EXISTING (To be retained)	Light Blue
EXISTING (To be demolished)	Light Yellow

**Buildingwise Floor FAR Details**

Floor Name	Building Name A (SRI SHIV LAL RAM)		Total	
	Proposed Built Up Area (Sq.mt.)	Proposed FAR Area (Sq.mt.)	Total Proposed Built Up Area (Sq.mt.)	Total FAR Area (Sq.mt.)
Ground Floor	82.70	82.70	82.70	82.70
First Floor	82.70	82.70	82.70	82.70
Terrace Floor	0.00	0.00	0.00	0.00
Total :	165.40	165.40	165.40	165.40

**Building :A (SRI SHIV LAL RAM)**

Floor Name	Total Built Up Area (Sq.mt.)	Proposed FAR Area (Sq.mt.)	Total FAR Area (Sq.mt.)	Total Consumed Additional FAR Area (Sq.mt.)	Tnmt (No.)
Ground Floor	82.70	82.70	82.70	82.70	01
First Floor	82.70	82.70	82.70	82.70	00
Terrace Floor	0.00	0.00	0.00	0.00	00
Total :	165.40	165.40	165.40	165.40	01
Total Number of Same Buildings :	1				
Total :	165.40	165.40	165.40	165.40	01

LTP NAME AND SIGNATURE	STRUCTURAL ENG'S NAME AND SIGNATURE	BUILDER NAME AND SIGNATURE
KUMARI RINKU RANI DMC/ENG/0016/2016		

Proposal Basic Information	
Proposal File No.	DMC/BP/0148/W22/2017
Owner Name	SRI SHIV LAL RAM
Khata No	11
Plot No	148
Village Name	Bhelaland
Use	Residential
SubUse	Boarding

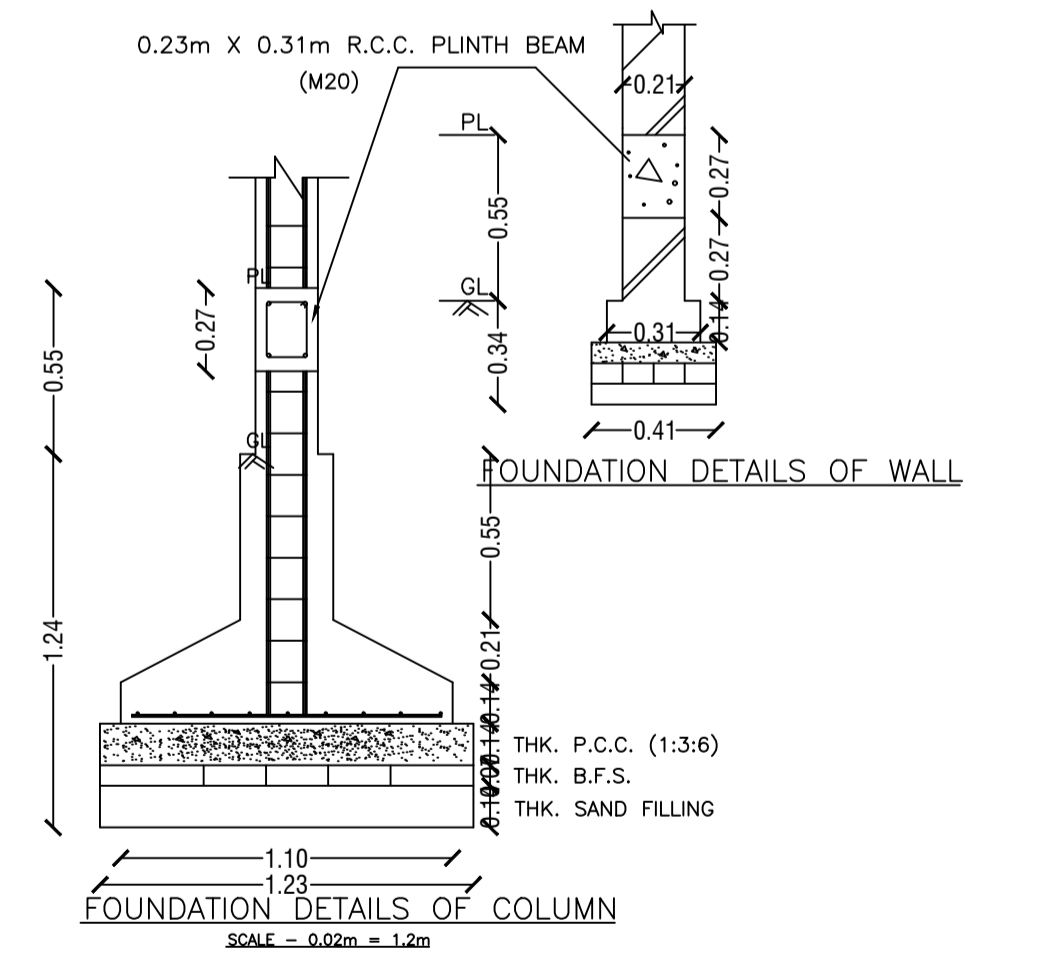
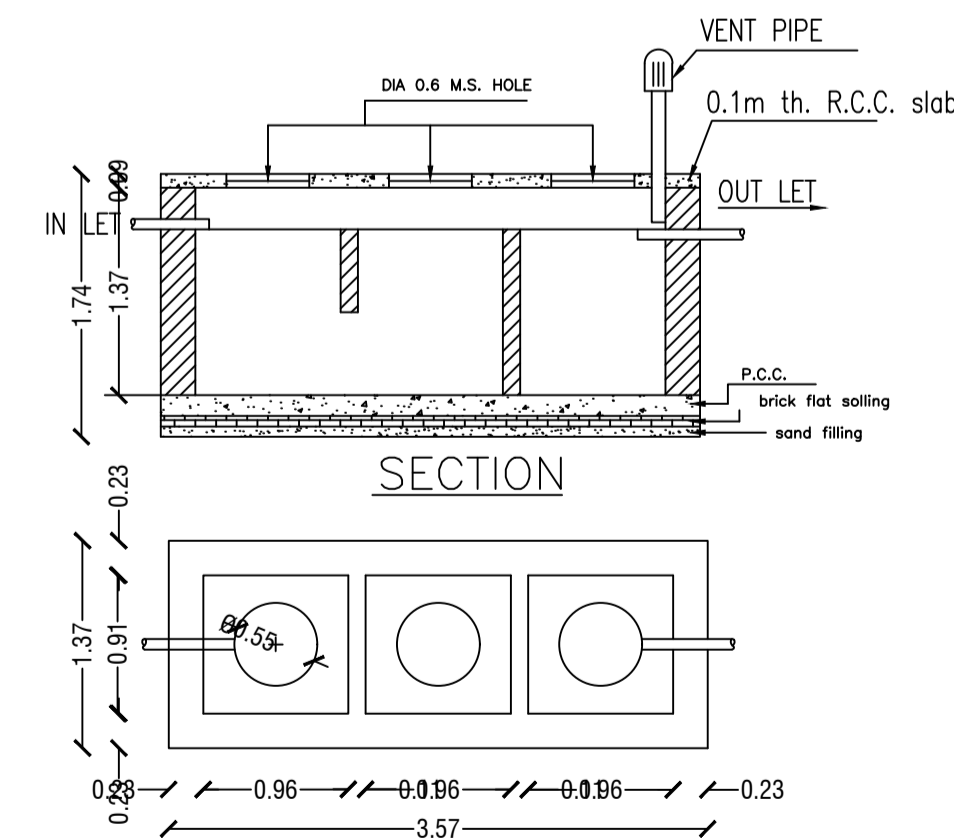
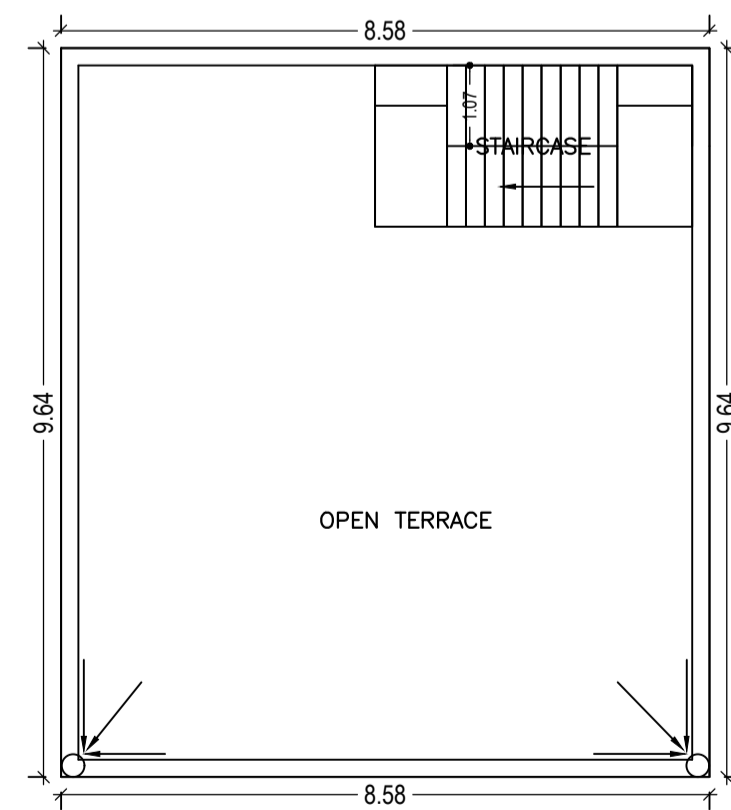
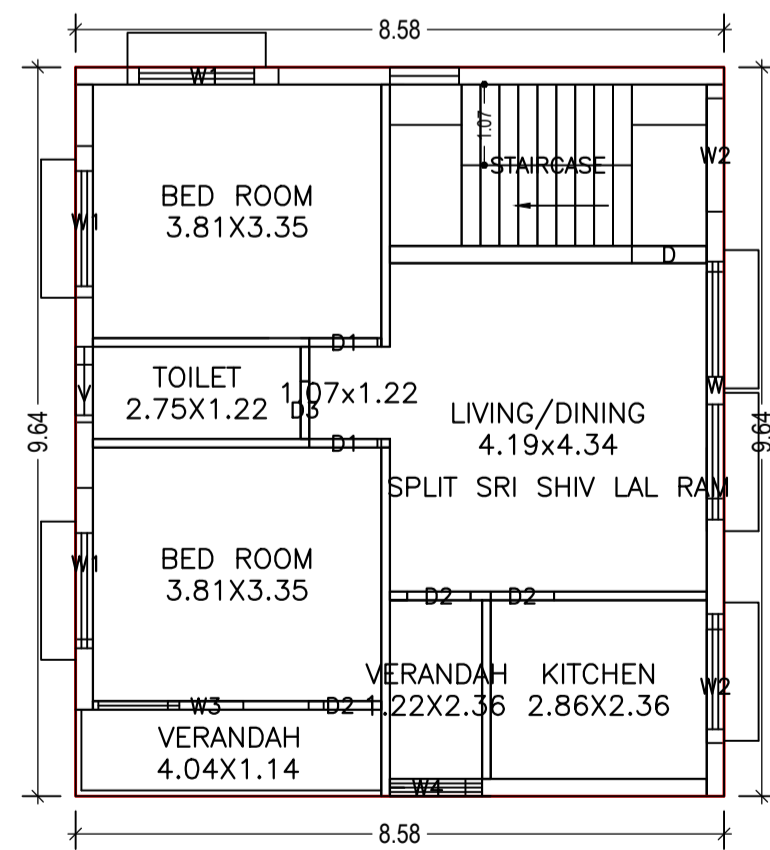
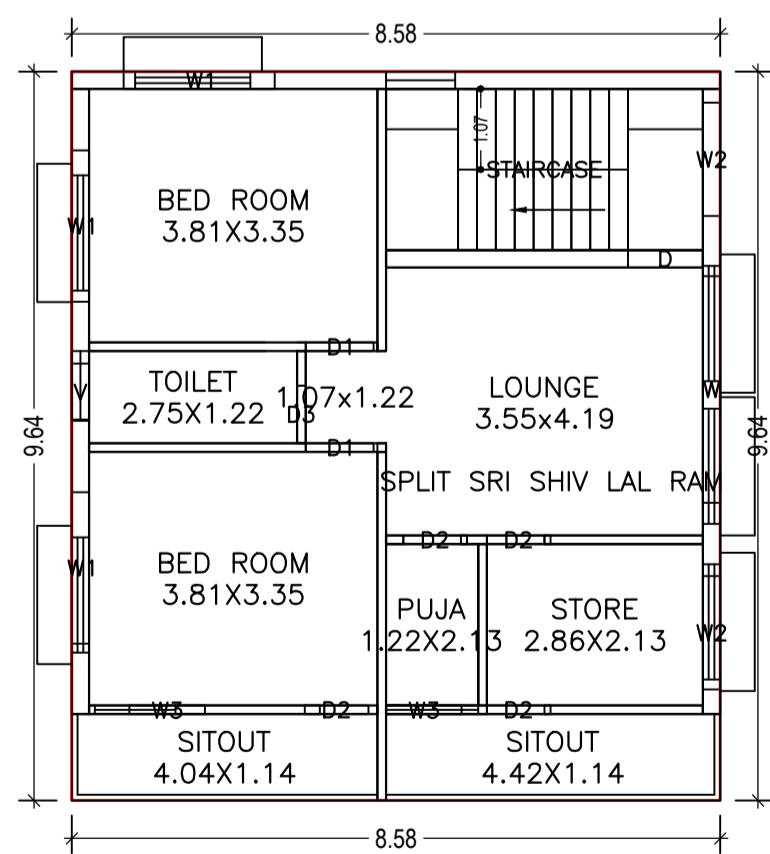
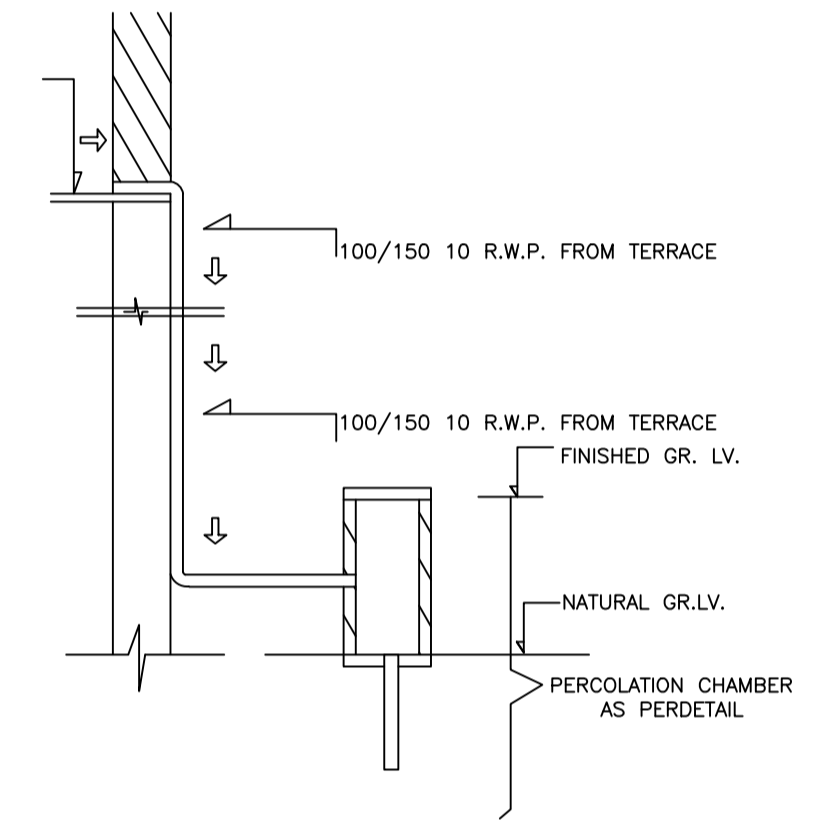
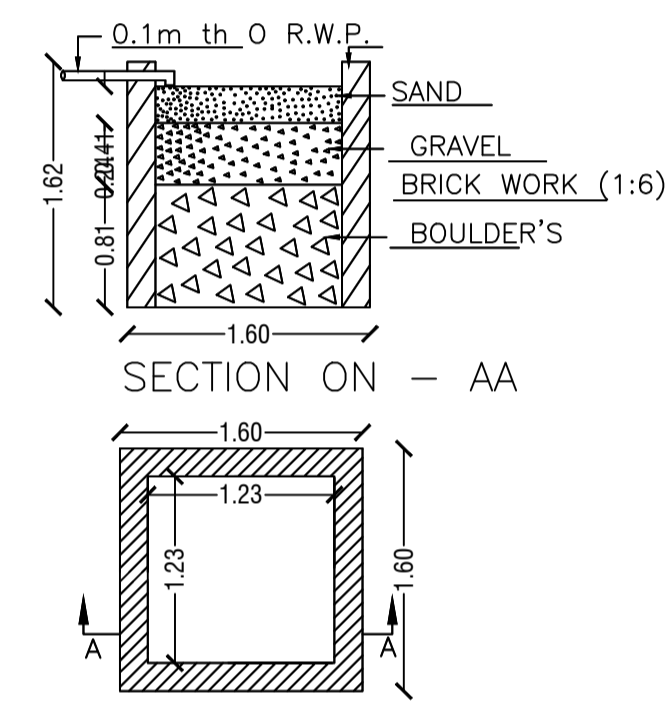
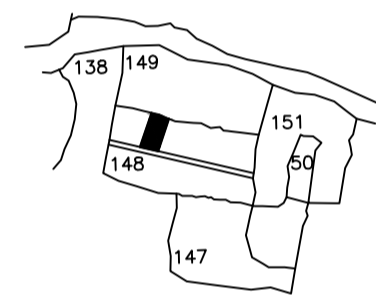
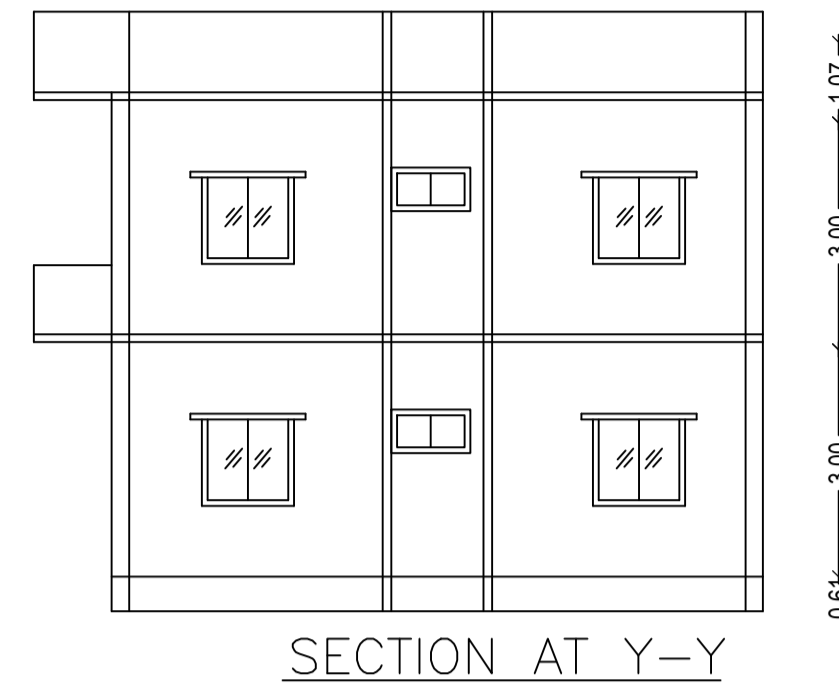
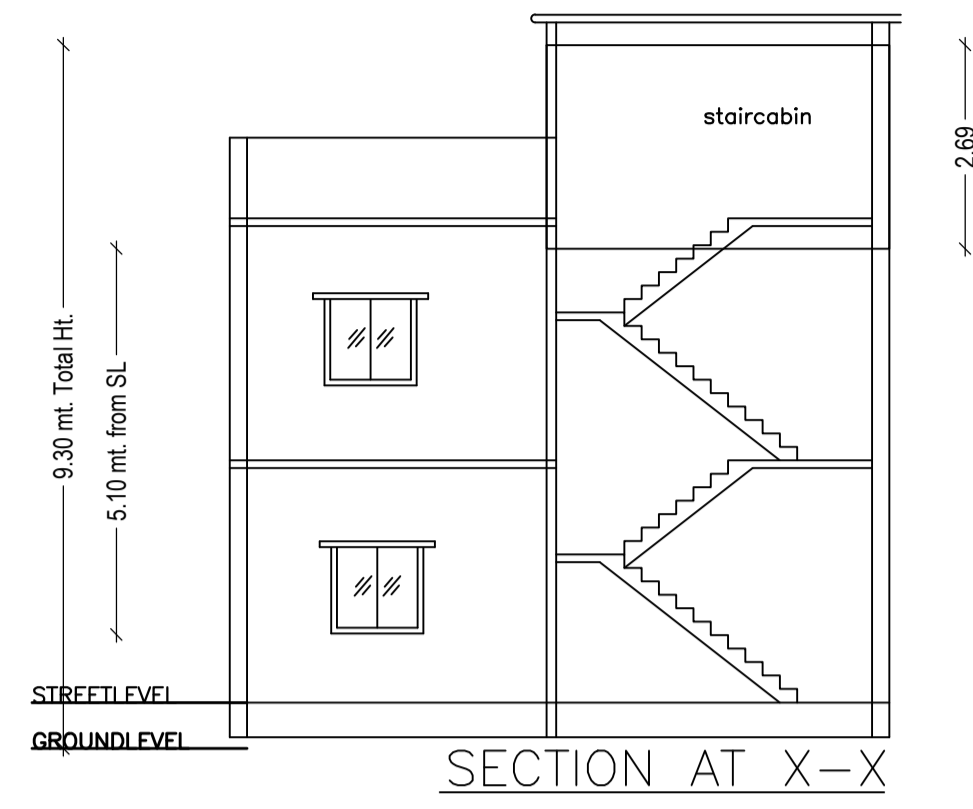
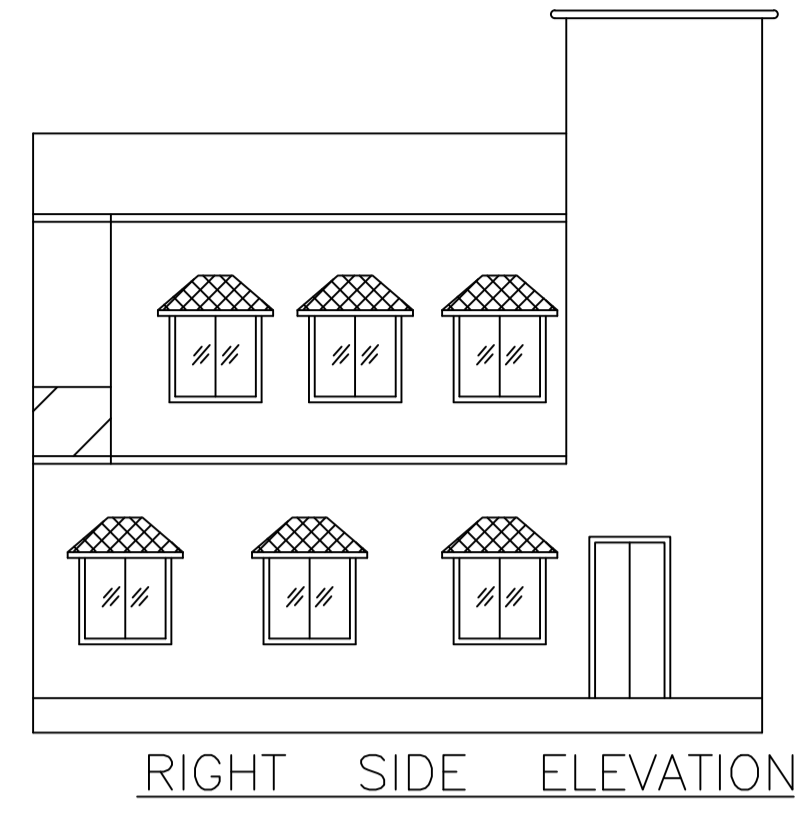
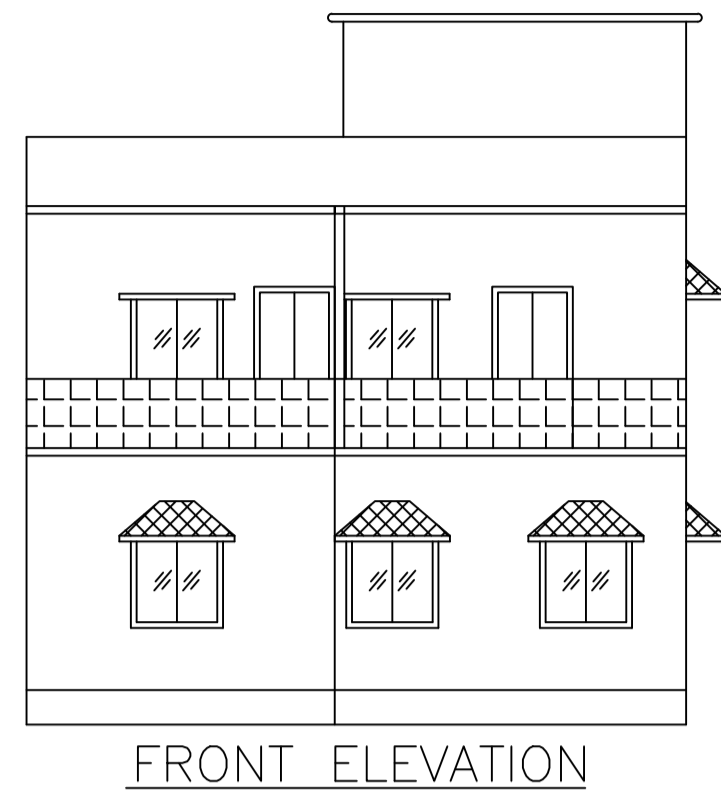

LTP NAME AND SIGNATURE	STRUCTURAL ENG'S NAME AND SIGNATURE	BUILDER NAME AND SIGNATURE
KUMARI RINKU RANI DMC/ENG/0016/2016		