

DETAIL OF COLUMNS

AREA STATEMENT		VERSION NO.: 1.0.19 m
DHANBAD MUNICIPAL CORPORATION		VERSION DATE: 13/06/2017
PROJECT DETAIL:		
Region: JHARKHAND URBAN LOCAL BODIES	Plot Use: Residential	
District: DHANBAD	Plot/SubPlot No: 96	
Authority: DHANBAD MUNICIPAL CORPORATION	Plot/Neighbourly/Religious Structure: NA	
Inward No: DMC/BP/0149/W22/2017	North: Road Width - 4.57	
Application Type: General Proposal	South: Plot No. - 96	
Project Type: Building Permission	East: Plot No. - VENDOR'S NIZ	
Nature of Development: New	West: Road Width - 3.66	
Location of Development Area: Old Area		
AREA DETAILS:		
AREA OF PLOT (Minimum)	(A)	SQ.MT. 133.51
Deduction for NetPlot Area	Surrender Free of Cost	5.51
Total		5.51
NET AREA OF PLOT (Gross Plot Area - Deduction from Gross Plot area)	(A-Deductions)	128.00
Deduction for Balance Plot Area (from Gross Plot Area)		
Surrender Free of Cost		5.51
Common Plot		25.14
Total		30.65
BALANCE AREA OF PLOT (Net Plot Area - Recreational/Amenity space)	(A-Deductions)	102.86
PLOT AREA FOR COVERAGE (Net Plot Area)	(A-Deductions)	128.00
Plot Area for FAR (Net Plot Area + Road Widening Area)	(A-Deductions)	133.51
COVERAGE CHECK		
Permissible Coverage area (70.00 %)		89.60
Proposed Coverage Area (63.64 %)		81.46
Total Prop. Coverage Area (63.64 %)		81.46
Balance coverage area (6.36 %)		8.14
FAR CHECK		
Perm. FAR Area (1.50)		200.26
Total Perm. FAR area		200.26
Residential FAR		162.93
Proposed FAR Area		162.93
Total Proposed FAR Area		162.93
Consumed FAR (Factor)		1.22
Balance FAR Area		37.33
BUILT UP AREA CHECK		
Total Proposed BuiltUp Area		162.92
ARCHITECT (Regd)	PARTHA - PAL	
ENGINEER (Regd)		
SUPERVISOR (Regd)		
OWNER (Regd)	SRI SUNIL KUMAR MADHESHIYA	
DEVELOPMENT AUTHORITY		LOCAL BODY

COLOR INDEX	
PLOT BOUNDARY	Black
ABUTTING ROAD	Red
PROPOSED CONSTRUCTION	Green
COMMON PLOT	Yellow
ROAD WIDENING AREA	Blue
EXISTING (To be retained)	Light Blue
EXISTING (To be demolished)	White

Buildingwise Floor FAR Details				
Floor Name	Building Name A (A)		Total	
	Proposed Built Up Area (Sq.mt.)	Proposed FAR Area (Sq.mt.)	Total Proposed Built Up Area (Sq.mt.)	Total FAR Area (Sq.mt.)
Ground Floor	81.46	81.46	81.46	81.46
First Floor	81.46	81.46	81.46	81.46
Terrace Floor	0.00	0.00	0.00	0.00
Total :	162.92	162.92	162.92	162.92

Building USE/SUBUSE Details			
Building Name	Building Use	Building SubUse	Building Structure
A (A)	Residential	Residential Bldg/Apartment	Non-Highrise

FAR & Tenement Details (Table 4c-1)						
Building	No. of Same Bldg	Total Built Up Area (Sq.mt.)	Proposed FAR Area (Sq.mt.) Resi.	Total FAR Area (Sq.mt.)	Total Consumed Additional FAR Area (Sq.mt.)	Tnmt (No.)
A (A)	1	162.92	162.92	162.92	162.92	01
Grand Total :	1	162.92	162.92	162.92	162.92	01

SCHEDULE OF DOOR:				
BUILDING NAME	NAME	LENGTH	HEIGHT	NOS
A (A)	D	0.90	2.10	10

SCHEDULE OF WINDOW/VENTILATION:				
BUILDING NAME	NAME	LENGTH	HEIGHT	NOS
A (A)	W	1.20	1.20	33

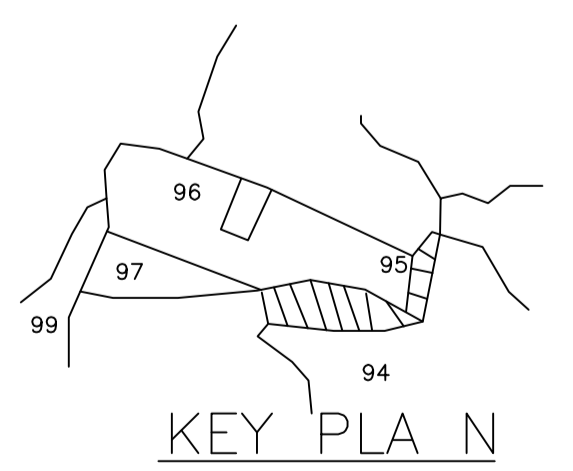
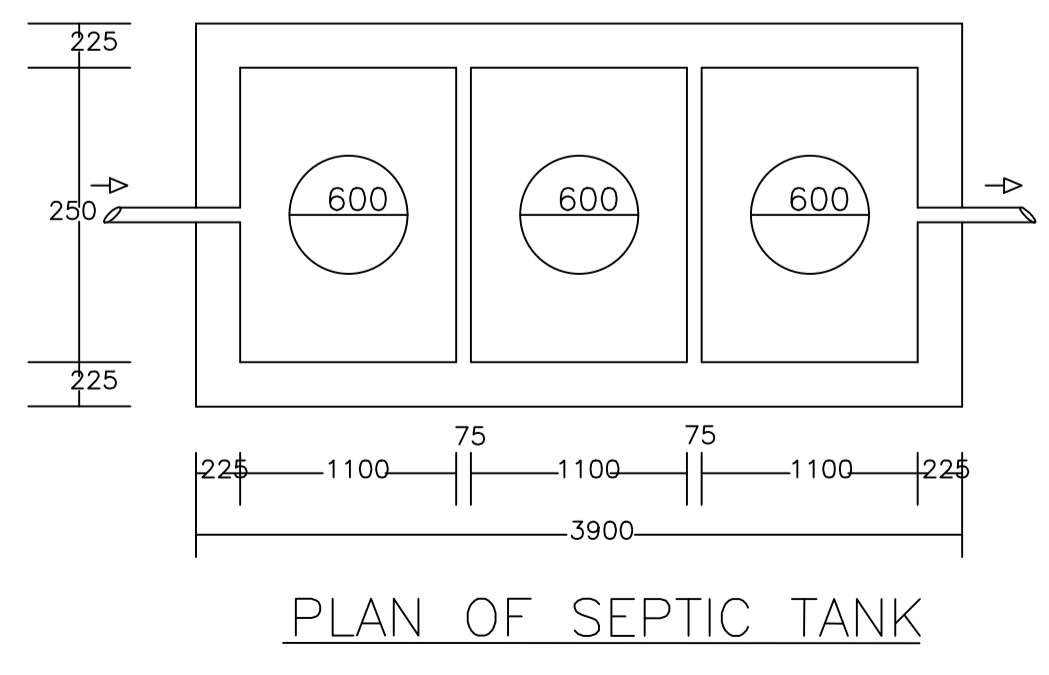
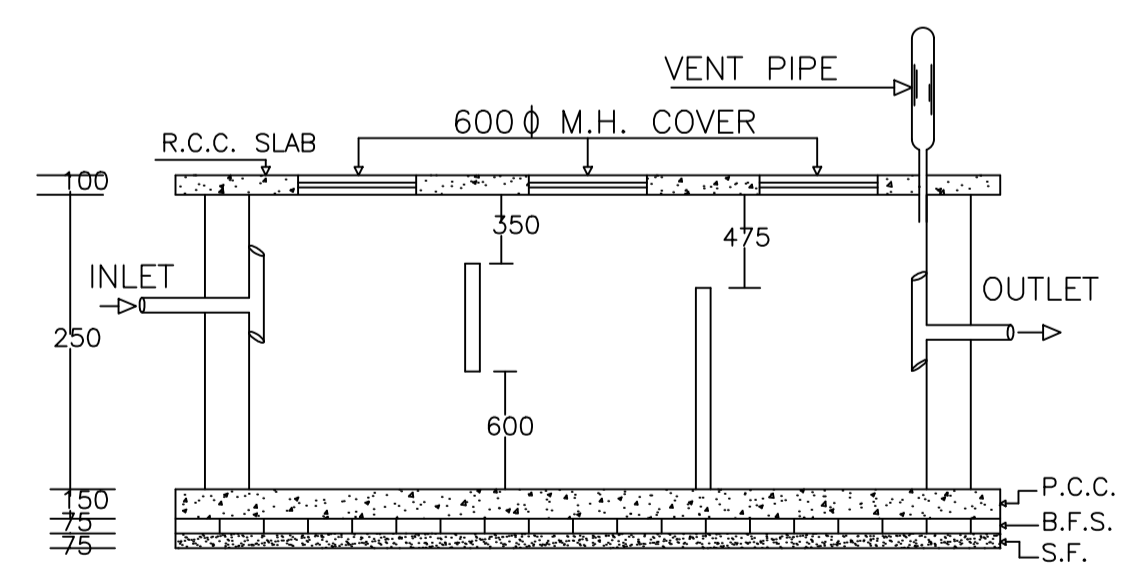
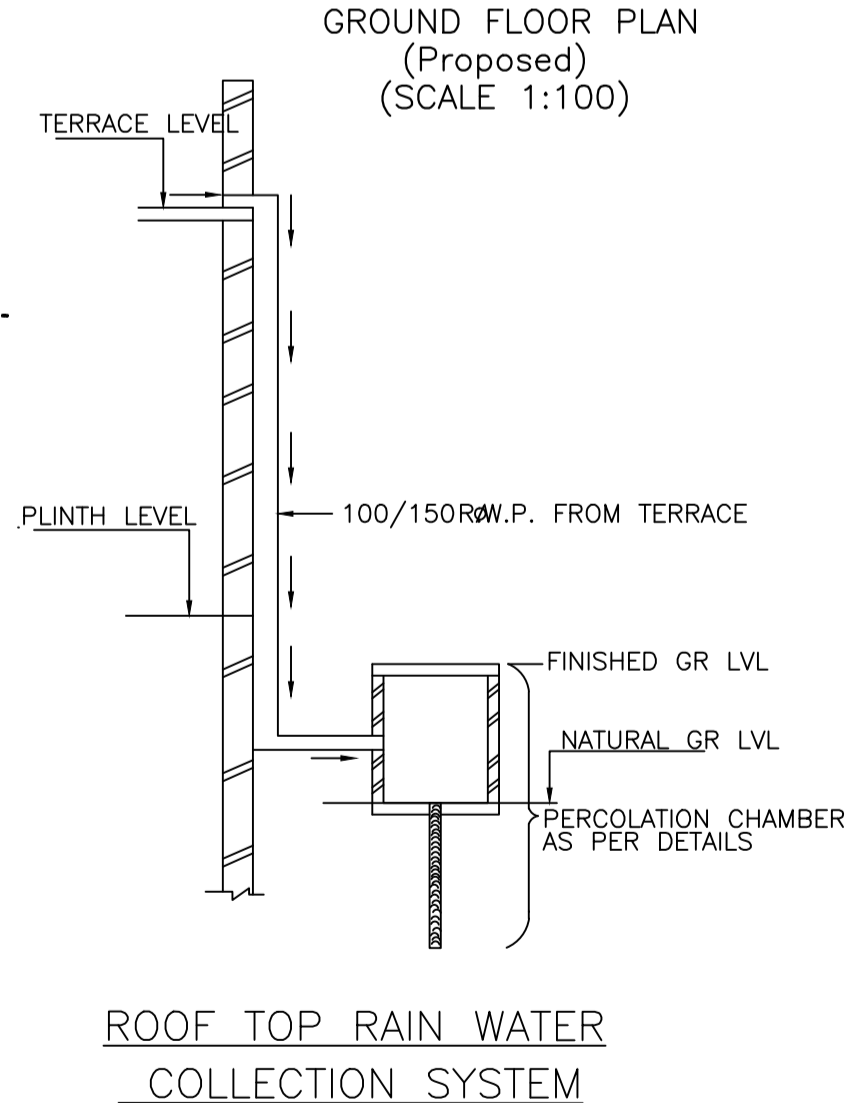
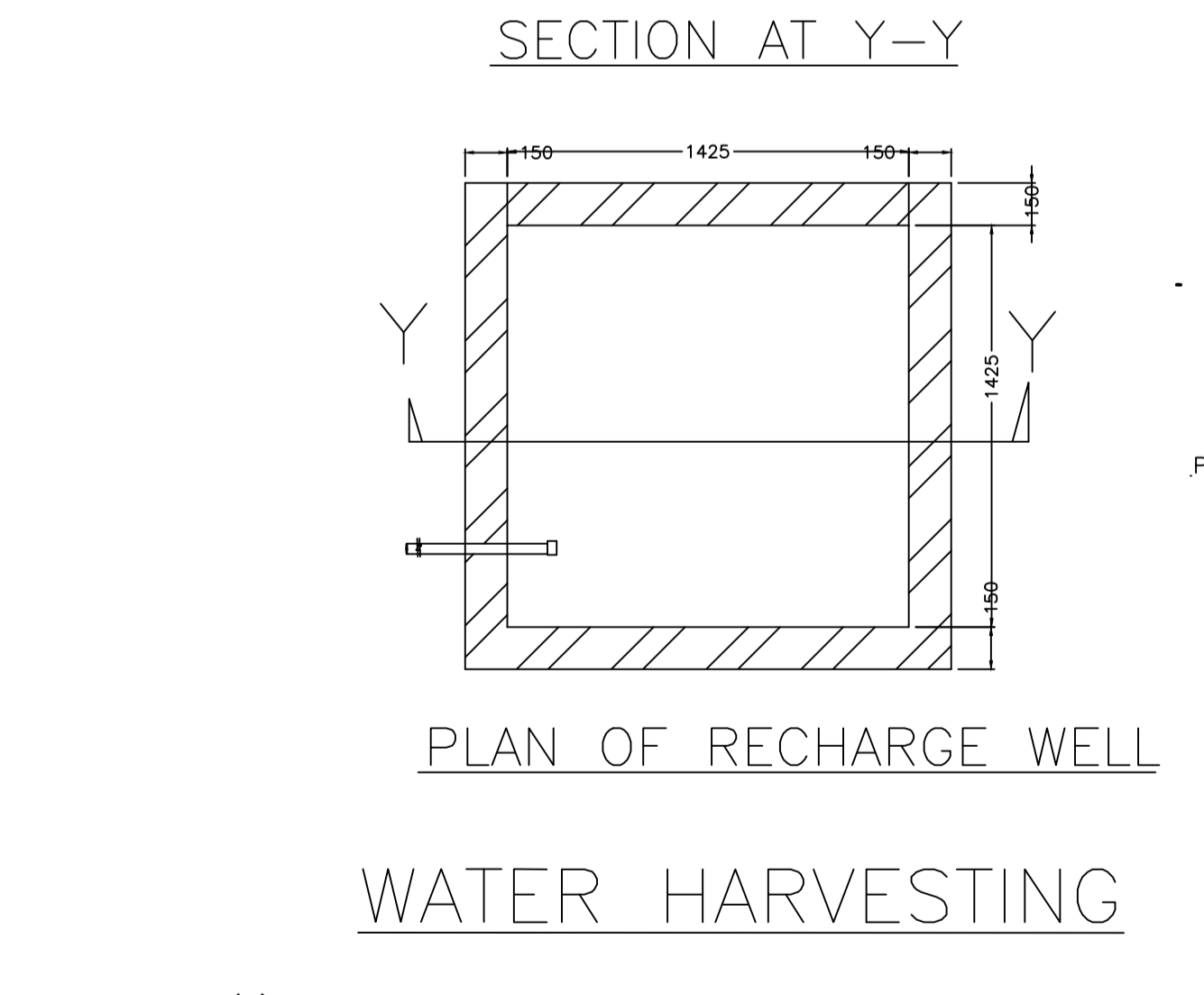

Building :A (A)					
Floor Name	Total Built Up Area (Sq.mt.)	Proposed FAR Area (Sq.mt.) Resi.	Total FAR Area (Sq.mt.)	Total Consumed Additional FAR Area (Sq.mt.)	Tnmt (No.)
Ground Floor	81.46	81.46	81.46	81.46	01
First Floor	81.46	81.46	81.46	81.46	00
Terrace Floor	0.00	0.00	0.00	0.00	00
Total :	162.92	162.92	162.92	162.92	01
Total Number of Same Buildings :	1				
Total :	162.92	162.92	162.92	162.92	01

UnitBUA Table for Building :A (A)						
FLOOR	Name	UnitBUA Type	UnitBUA Area	Carpet Area	No. of Rooms	No. of Tenement
GROUND FLOOR PLAN	SPLIT 1	FLAT	162.93	157.09	6	1
FIRST FLOOR PLAN	SPLIT 1	FLAT	0.00	0.00	6	0
Total:	-	-	162.93	157.09	12	1

LTP NAME AND SIGNATURE	STRUCTURAL ENG'S NAME AND SIGNATURE	BUILDER NAME AND SIGNATURE
PARTHA - PAL DMC/ENG/0021/2016		

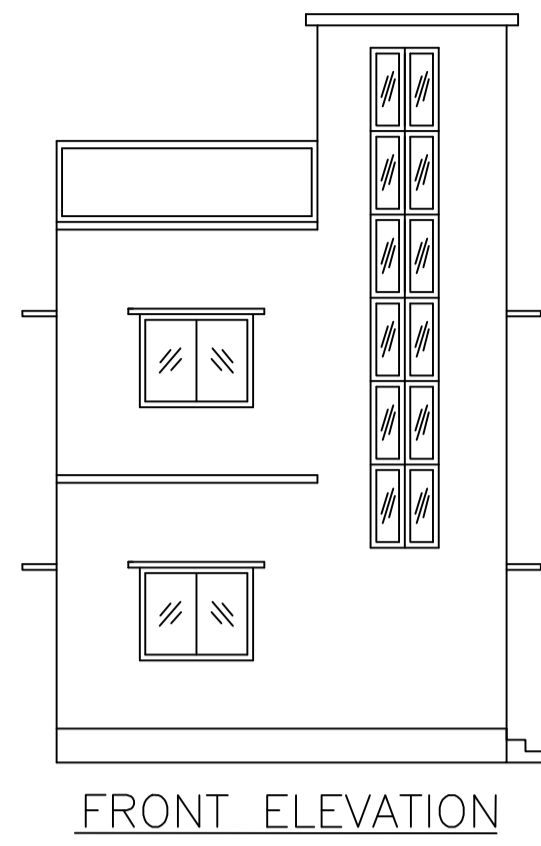

FRONT ELEVATION

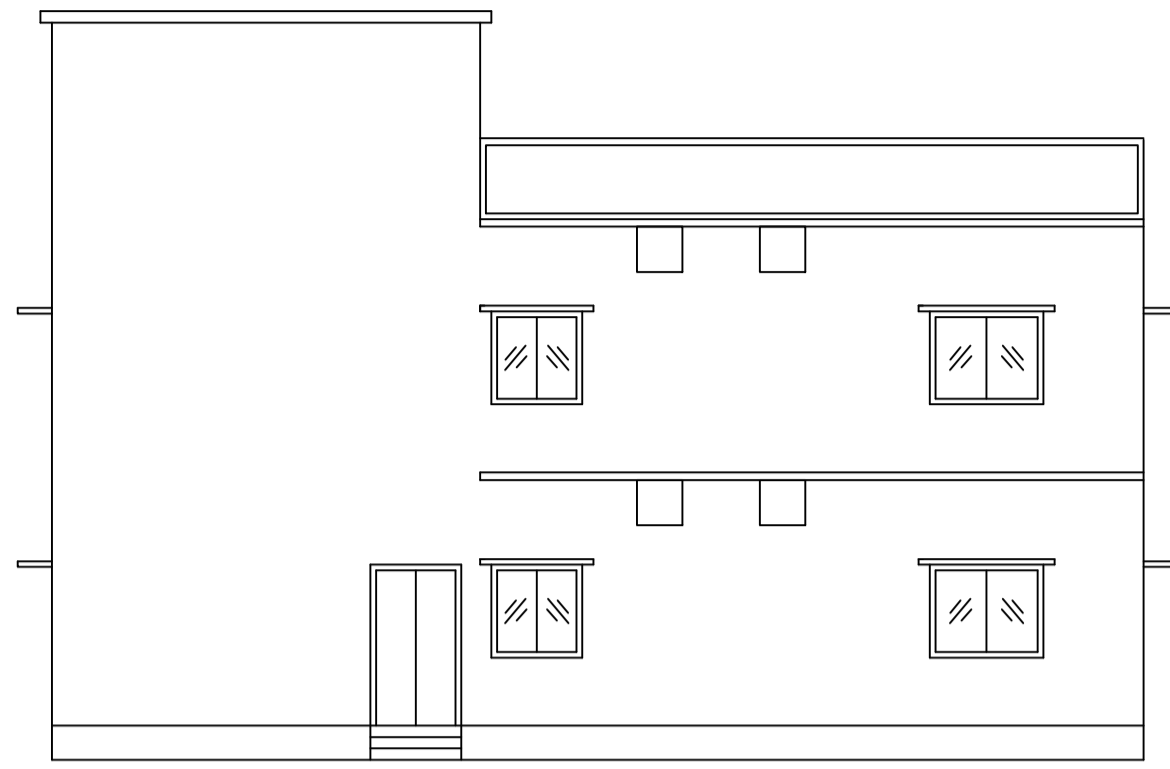

RIGHT SIDE ELEVATION

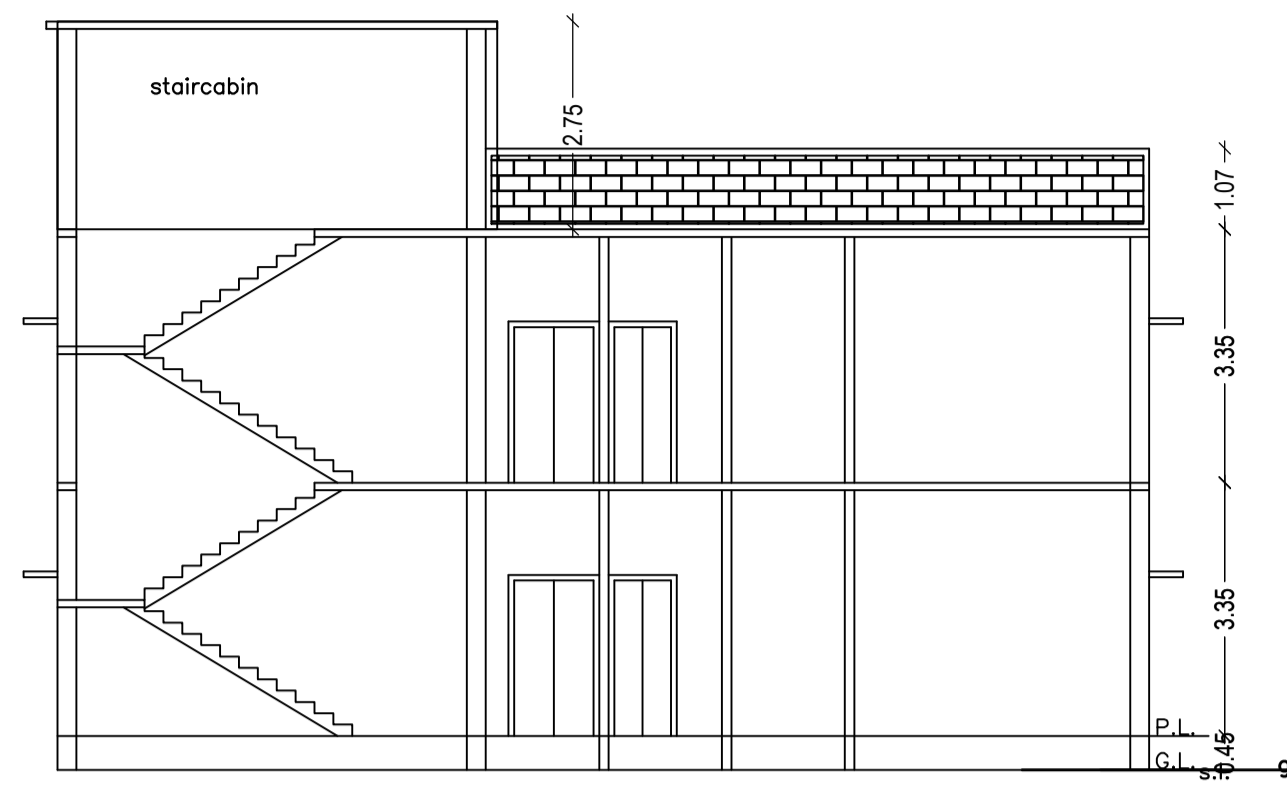

SECTION ON X-X

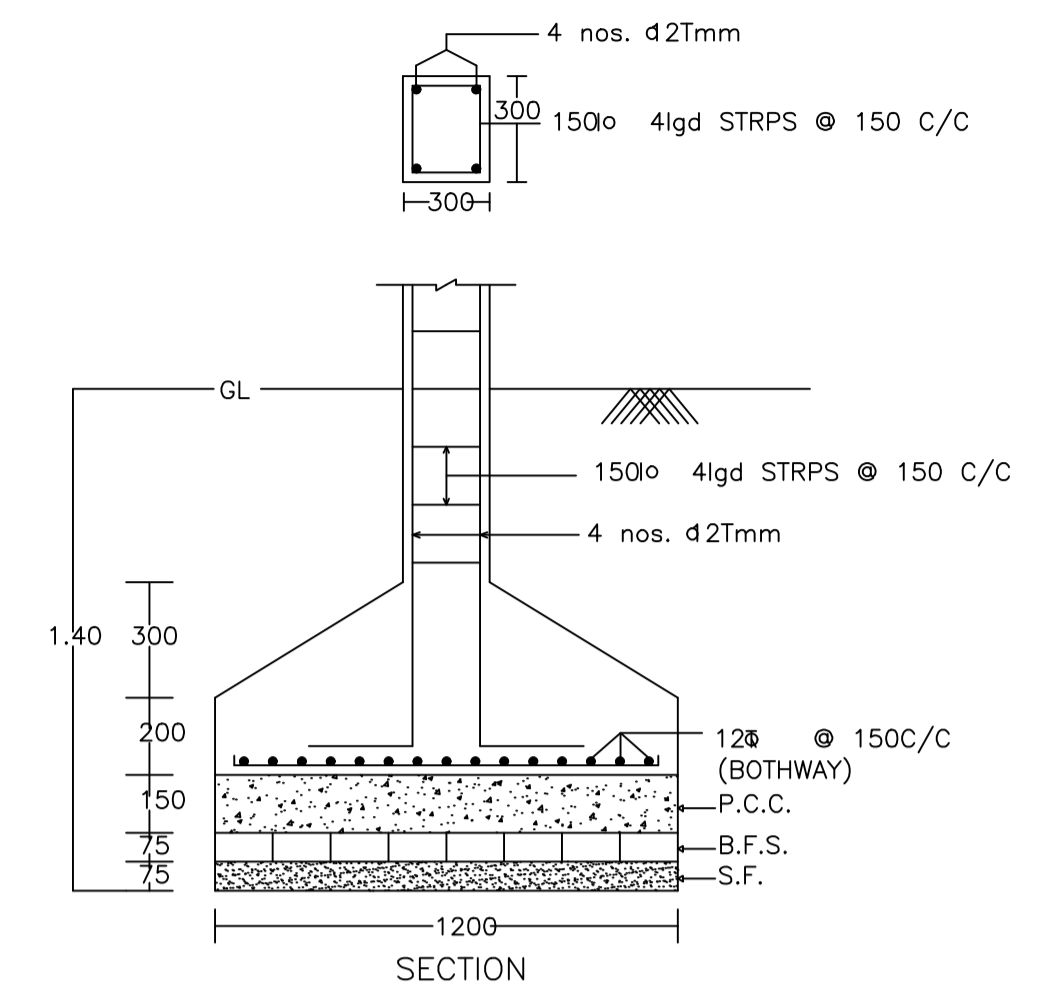

SECTION

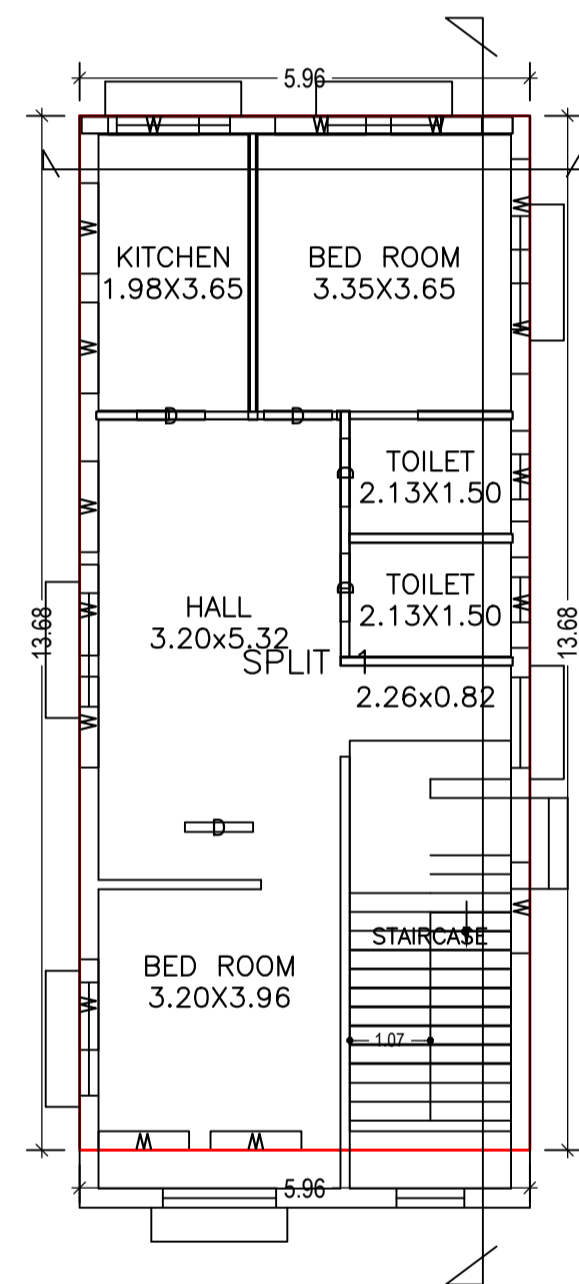

GROUND FLOOR PLAN
(Proposed)
(SCALE 1:100)

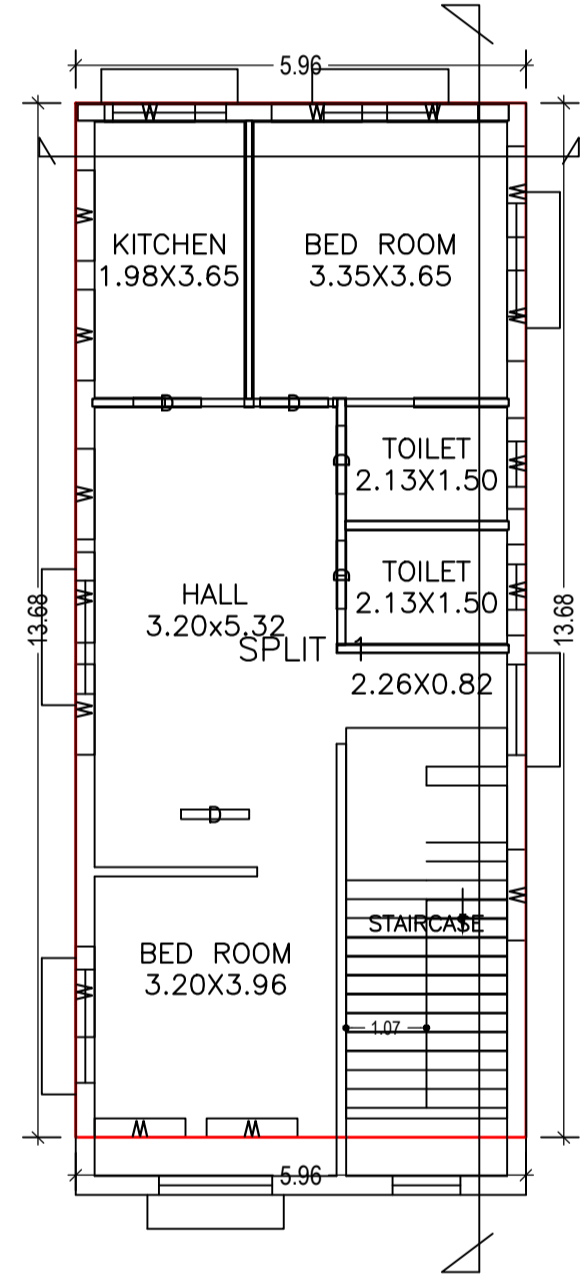

FIRST FLOOR PLAN
(Proposed)
(SCALE 1:100)

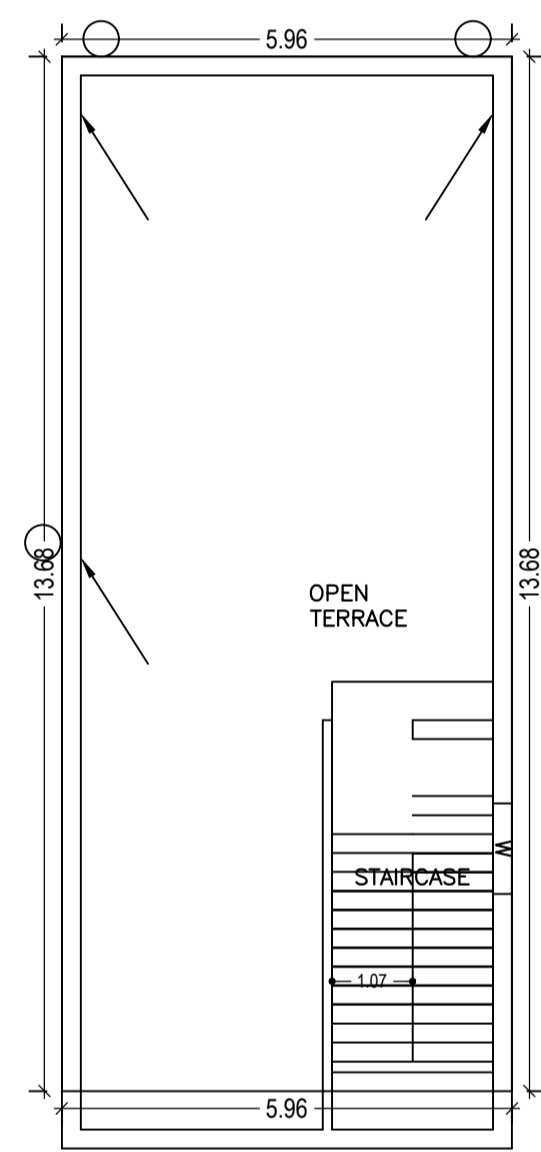

TERRACE FLOOR PLAN
(SCALE 1:100)

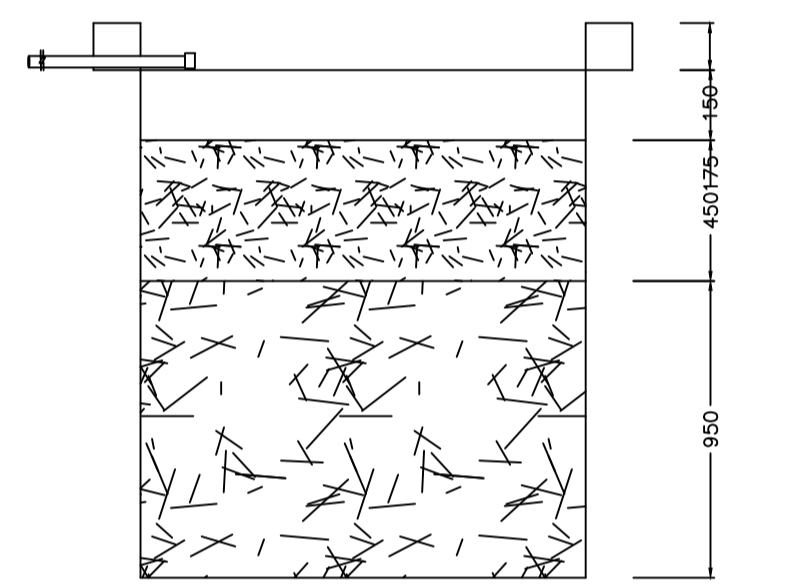

SECTION AT Y-Y

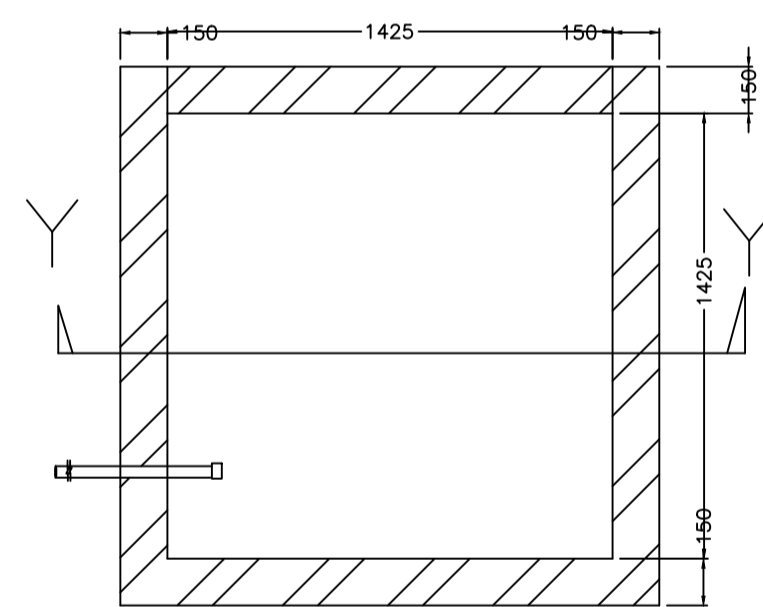

PLAN OF RECHARGE WELL

WATER HARVESTING

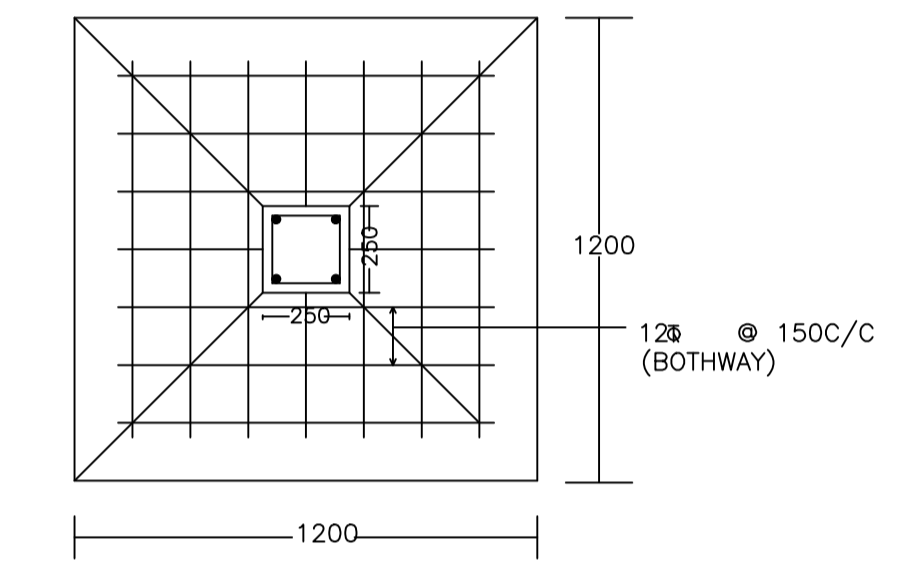

DETAIL OF COLUMNS

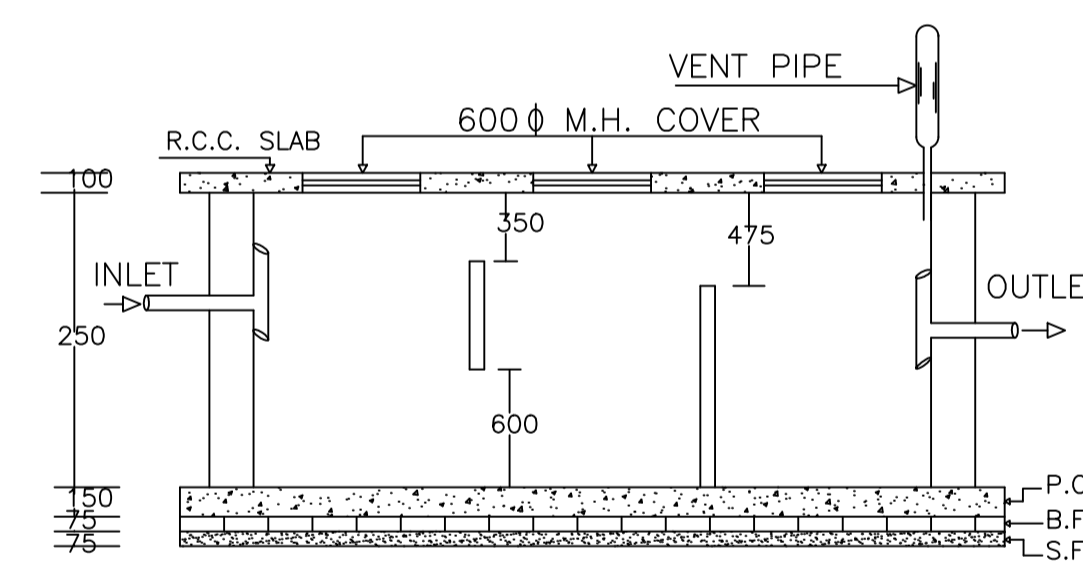

PLAN OF SEPTIC TANK

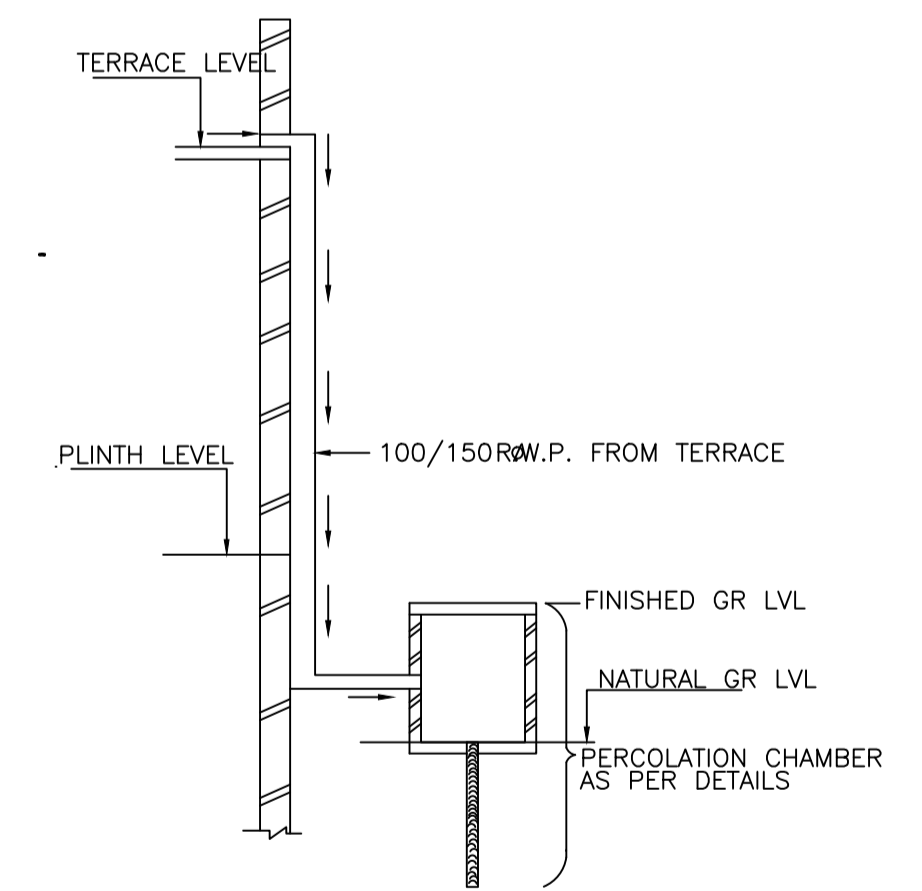

ROOF TOP RAIN WATER
COLLECTION SYSTEM

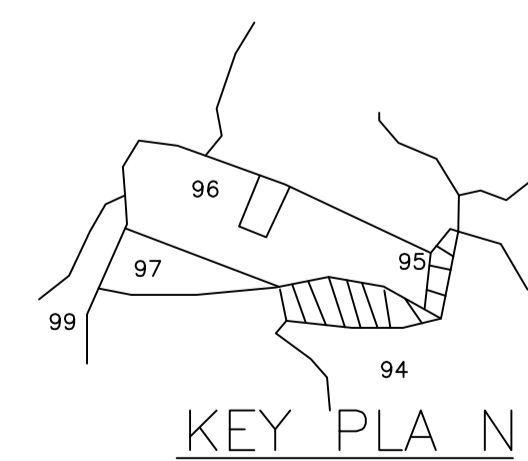

KEY PLAN

SCHEDULE OF DOOR:

BUILDING NAME	NAME	LENGTH	HEIGHT	NOS
A (A)	D	0.90	2.10	10

SCHEDULE OF WINDOW/VENTILATION:

BUILDING NAME	NAME	LENGTH	HEIGHT	NOS
A (A)	W	1.20	1.20	33

LTP NAME AND SIGNATURE	STRUCTURAL ENG'S NAME AND SIGNATURE	BUILDER NAME AND SIGNATURE
PARTHA - PAL DMC/ENG/0021/2016		