

DETAILS OF SEPTIC TANK

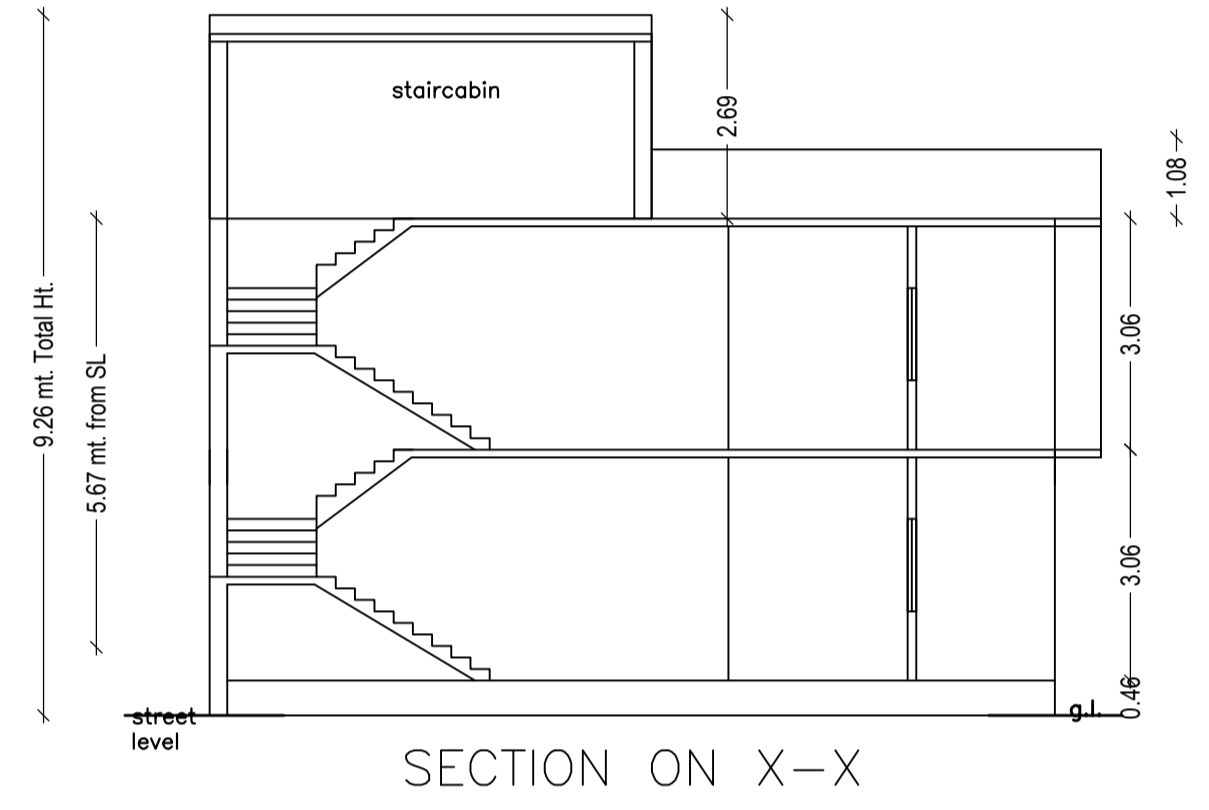

SECTION ON X-X

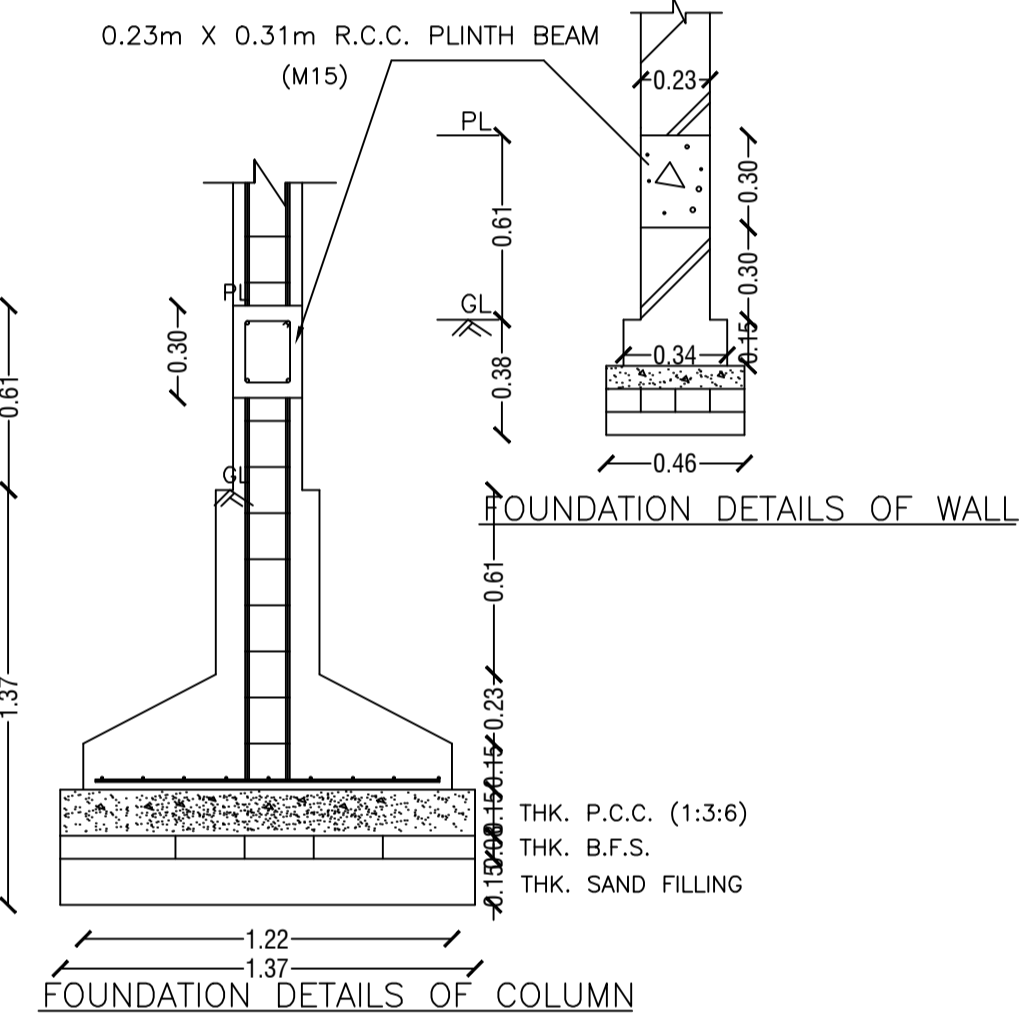

FOUNDATION DETAILS OF WALL
FOUNDATION DETAILS OF COLUMN

AREA STATEMENT		VERSION NO. : 1.0.28
DHANBAD MUNICIPAL CORPORATION		VERSION DATE: 30/06/2018
PROJECT DETAIL:		
Region: JHARKHAND URBAN LOCAL BODIES	Plot Use: Residential	
District: DHANBAD	Plot SubUse: Boarding	
Authority: DHANBAD MUNICIPAL CORPORATION	PlotNearbyReligiousStructure: NA	
Inward No: DMC/BP/0123/W23/2017	Plot/SubPlot No: 1970	
Application Type: General Proposal	North: Road Width - 4.27	
Project Type: Building Permission	South: Plot No. - 1971	
Nature of Development: New	East: Plot No. - 1970	
Location of Development Area: Old Area	West: Plot No. - 1971	
AREA DETAILS:		
AREA OF PLOT (Minimum)	(A)	SQ.MT. 302.63
NET AREA OF PLOT(Gross Plot Area - Deduction from Gross Plot area)	(A-Deductions)	302.63
Deduction for Balance Plot Area(from Gross Plot Area)		
Common Plot		73.48
Total		73.48
BALANCE AREA OF PLOT(Net Plot Area - Recreational/Amenity space)	(A-Deductions)	229.15
PLOT AREA FOR COVERAGE(Net Plot Area)	(A-Deductions)	302.63
Plot Area for FAR (Net Plot Area + RoadWidening Area)	(A-Deductions)	302.63
COVERAGE CHECK		
Permissible Coverage area (60.00 %)		181.58
Proposed Coverage Area (46.99 %)		
Total Prop. Coverage Area (46.99 %)		142.19
Balance coverage area (13.02 %)		39.39
FAR CHECK		
Perm. FAR Area (1.80)		544.73
Total Perm. FAR area		544.73
Residential FAR		289.65
Proposed FAR Area		289.65
Total Proposed FAR Area		289.65
Consumed FAR (Factor)		0.96
Balance FAR Area		255.08
BUILT UP AREA CHECK		
Total Proposed BuiltUp Area		289.65
ARCHITECT (Regd)		
ENGINEER (Regd)		
SUPERVISOR (Regd)		
OWNER (Regd)	SMT NIYOTI DEVI	
DEVELOPMENT AUTHORITY		LOCAL BODY

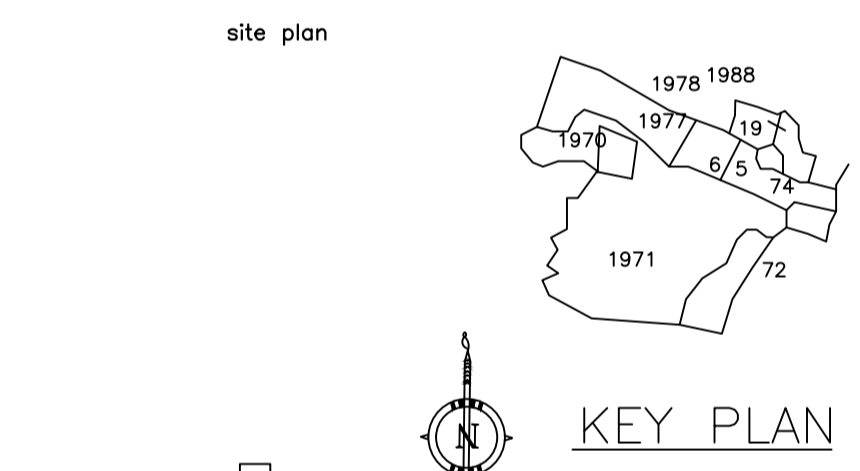

KEY PLAN

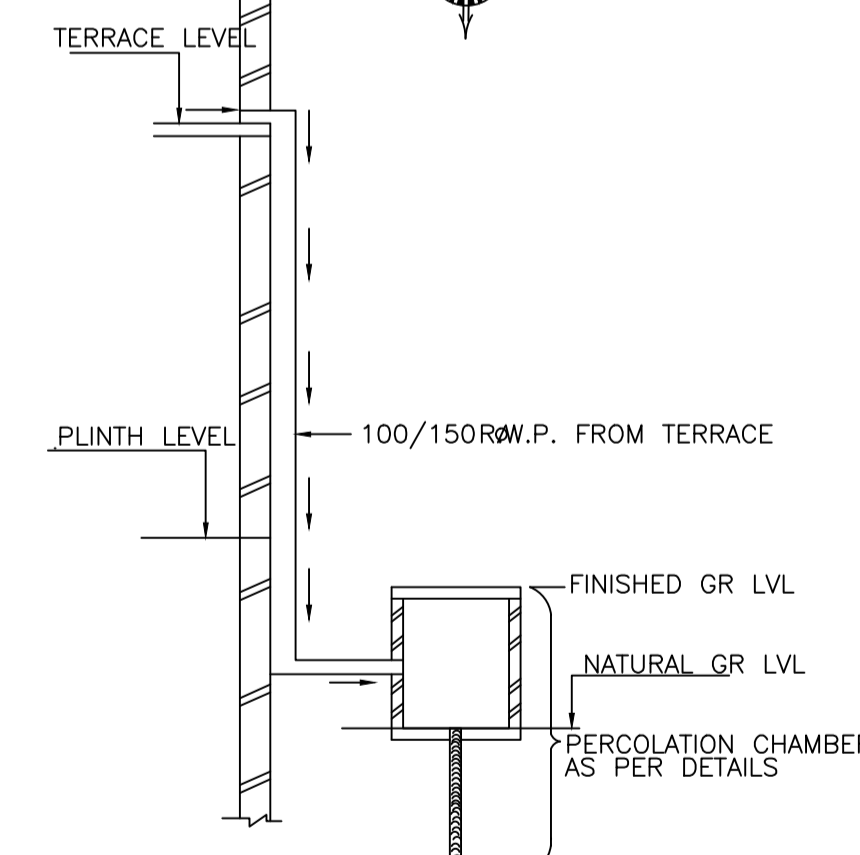

ROOF TOP RAIN WATER COLLECTION SYSTEM

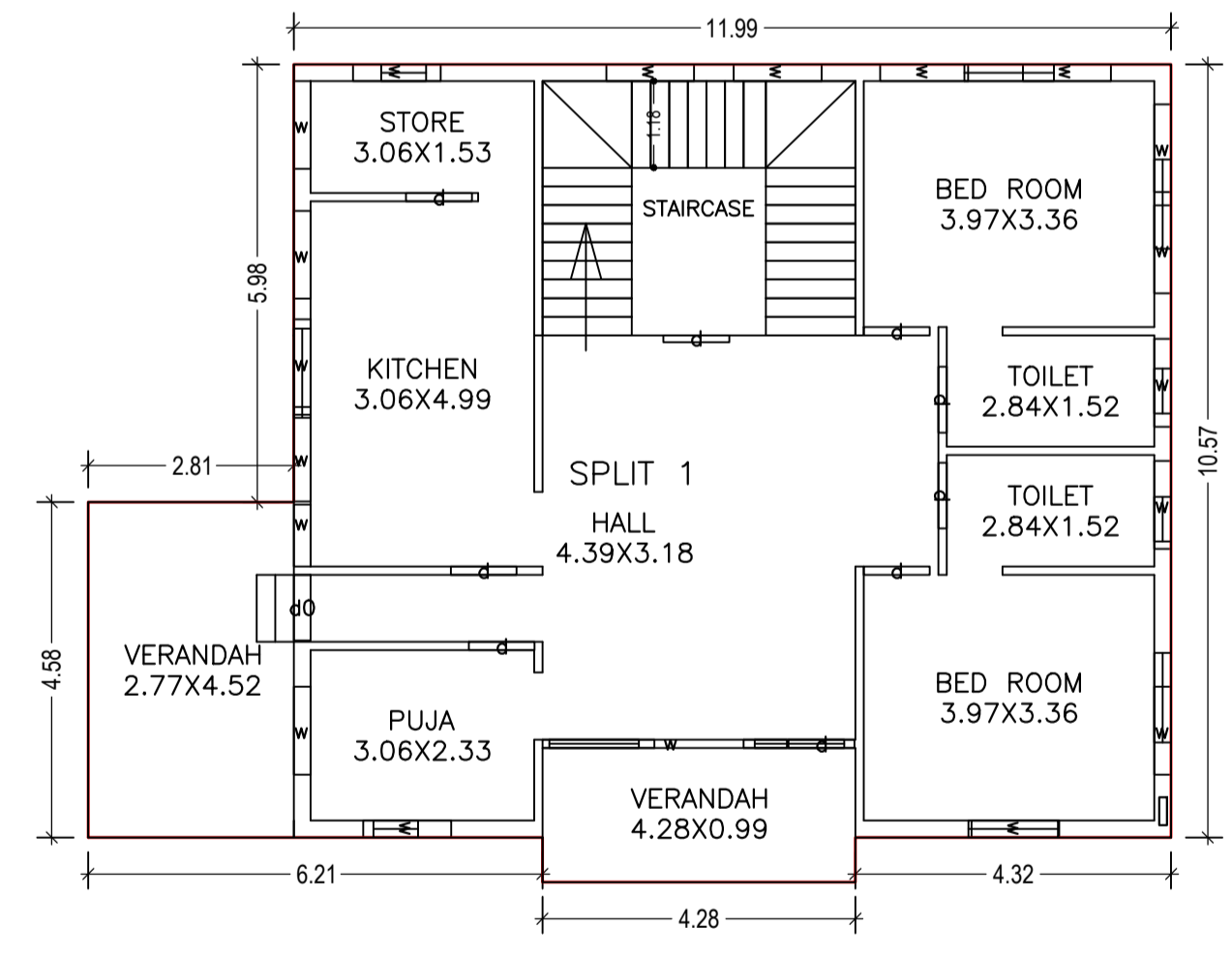

GROUND FLOOR PLAN (Proposed) (SCALE 1:100)

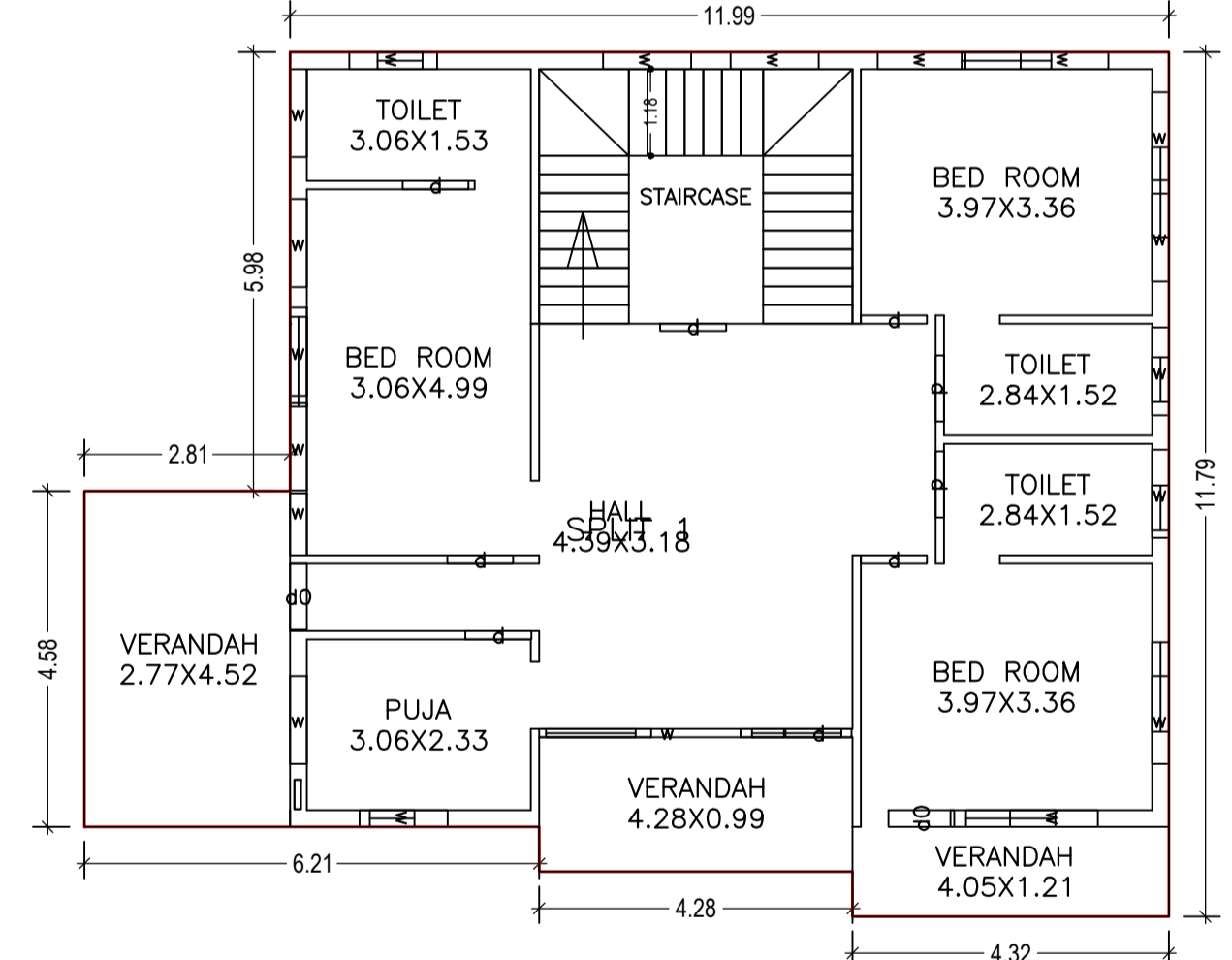

FIRST FLOOR PLAN (Proposed) (SCALE 1:100)

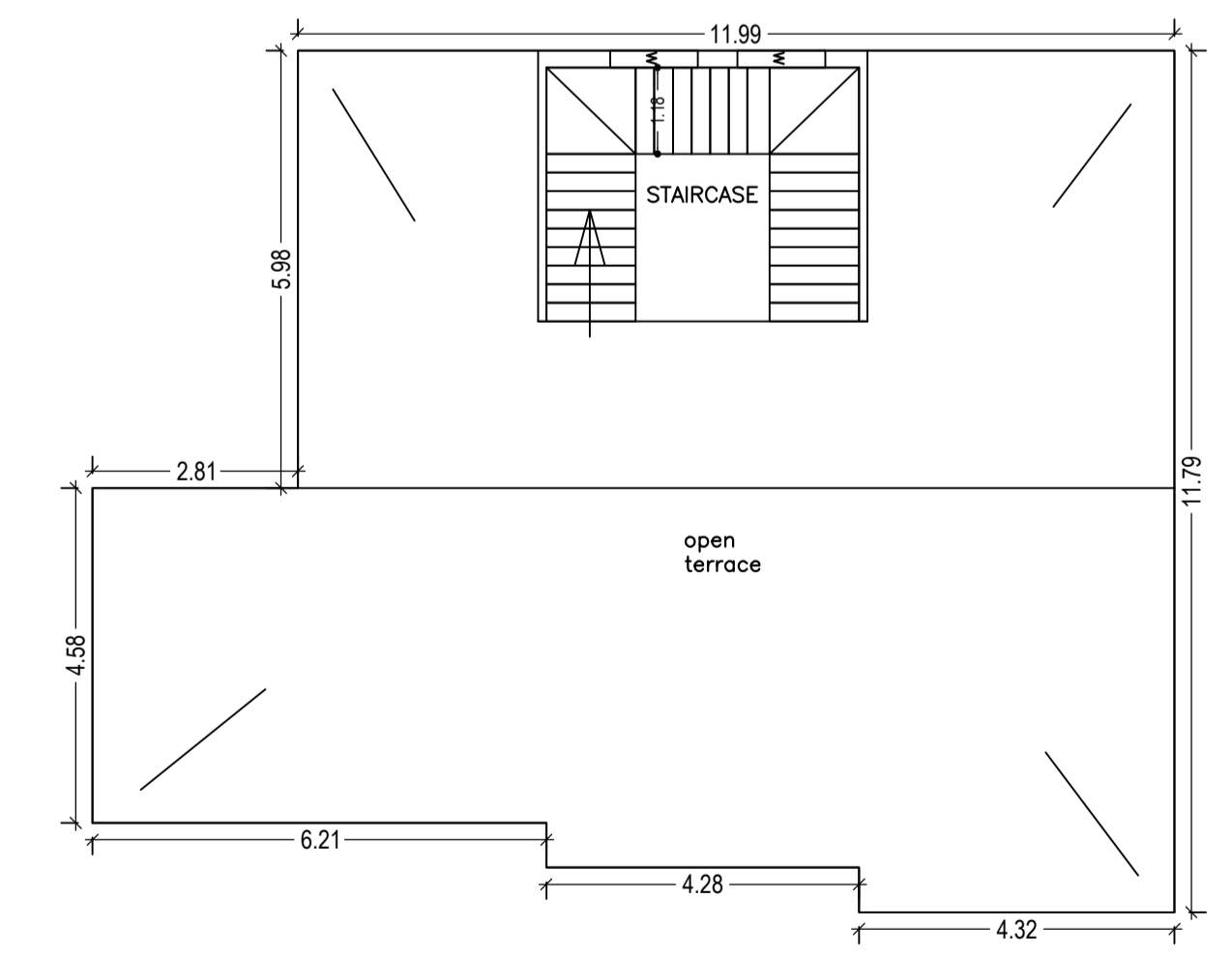

TERRACE FLOOR PLAN (SCALE 1:100)

COLOR INDEX	
PLOT BOUNDARY	Black
ABUTTING ROAD	Red
PROPOSED CONSTRUCTION	Green
COMMON PLOT	Yellow
ROAD WIDENING AREA	Blue
EXISTING (To be retained)	White
EXISTING (To be demolished)	Grey

Buildingwise Floor FAR Details

Floor Name	Building Name A (A)		Total	
	Proposed Built Up Area (Sq.mt.)	Proposed FAR Area (Sq.mt.)	Total Proposed Built Up Area (Sq.mt.)	Total FAR Area (Sq.mt.)
Ground Floor	142.19	142.19	142.19	142.19
First Floor	147.46	147.46	147.46	147.46
Terrace Floor	0.00	0.00	0.00	0.00
Total :	289.65	289.65	289.65	289.65

Building USE/SUBUSE Details

Building Name	Building Use	Building SubUse	Building Structure
A (A)	Residential	Residential Bldg/Apartment	Non-Highrise

FAR & Tenement Details (Table 4c-1)

Building	No. of Same Bldg	Total Built Up Area (Sq.mt.)	Proposed FAR Area (Sq.mt.) Res:	Total FAR Area (Sq.mt.)	Total Consumed Additional FAR Area (Sq.mt.)	Tnmt (No.)
A (A)	1	289.65	289.65	289.65	289.65	01
Grand Total :	1	289.65	289.65	289.65	289.65	01

Building :A (A)					
Floor Name	Total Built Up Area (Sq.mt.)	Proposed FAR Area (Sq.mt.) Res.	Total FAR Area (Sq.mt.)	Total Consumed Additional FAR Area (Sq.mt.)	Tnmt (No.)
Ground Floor	142.19	142.19	142.19	142.19	01
First Floor	147.46	147.46	147.46	147.46	00
Terrace Floor	0.00	0.00	0.00	0.00	00
Total :	289.65	289.65	289.65	289.65	01
Total Number of Same Buildings	1				
Total :	289.65	289.65	289.65	289.65	01

SCHEDULE OF DOOR:					
BUILDING NAME	NAME	LENGTH	HEIGHT	NOS	
A (A)	d	0.90	2.10	18	
A (A)	d0	0.90	2.10	03	

SCHEDULE OF WINDOW/VENTILATION:					
BUILDING NAME	NAME	LENGTH	HEIGHT	NOS	
A (A)	w	0.85	1.20	02	
A (A)	w	1.19	1.20	02	
A (A)	w	1.20	1.20	34	
A (A)	w	3.34	1.20	02	

UnitBUA Table for Building :A (A)						
FLOOR	Name	UnitBUA Type	UnitBUA Area	Carpet Area	No. of Rooms	No. of Tenement
GROUND FLOOR	SPLIT 1	FLAT	289.65	289.57		1
FIRST FLOOR	SPLIT 1	FLAT	0.00	0.00	11	0
Total:	-	-	289.65	289.57	21	1

LTP NAME AND SIGNATURE	STRUCTURAL ENG'S NAME AND SIGNATURE	BUILDER NAME AND SIGNATURE
KUMARI RINKU RANI DMC/ENG/0016/2016		

Proposal Basic Information	
Proposal File No.	DMC/BP/0123/W23/2017
Owner Name	SMT NIYOTI DEVI
Khata No	09
Plot No	1970
Village Name	Kolakusma
Use	Residential
SubUse	Boarding

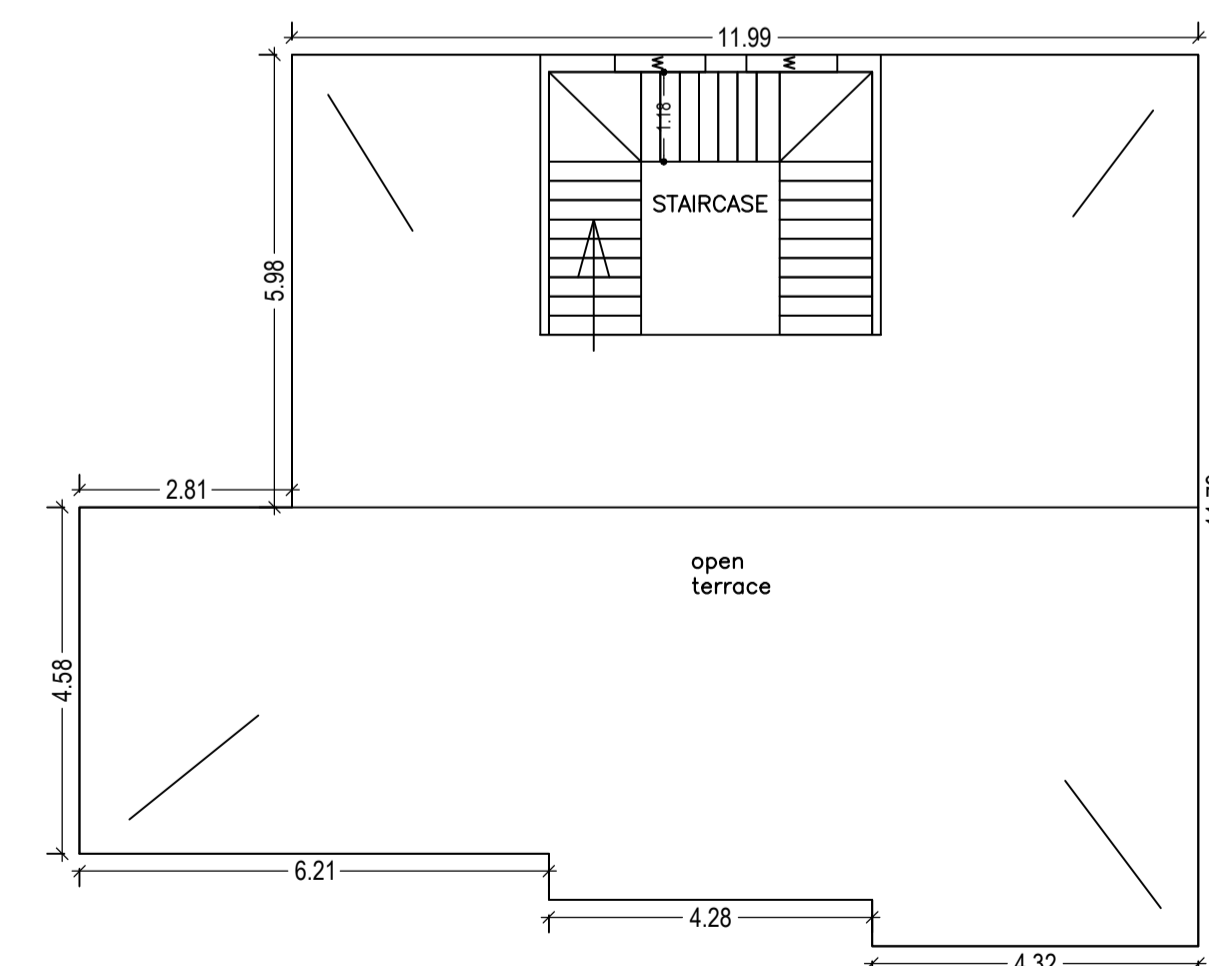
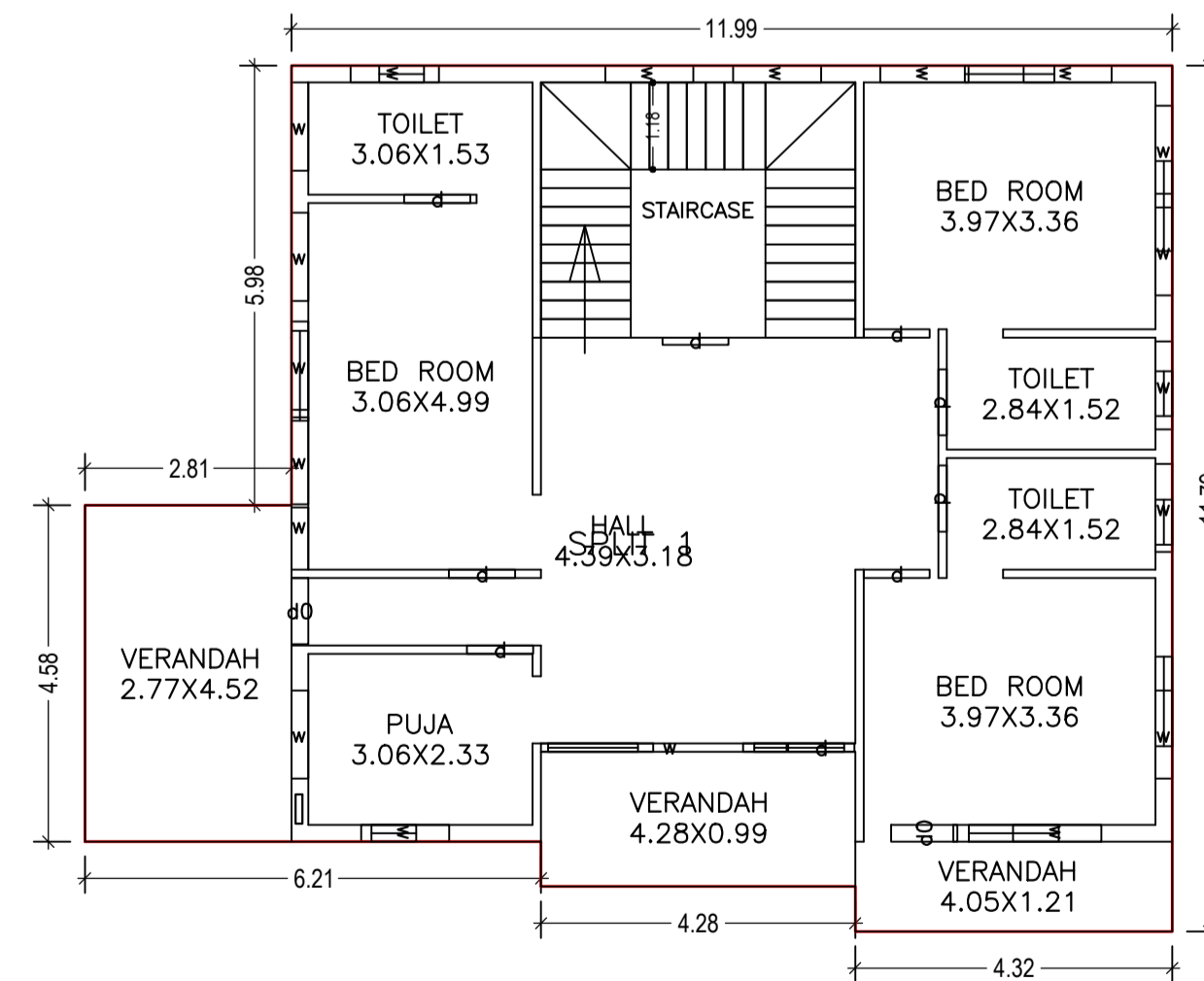
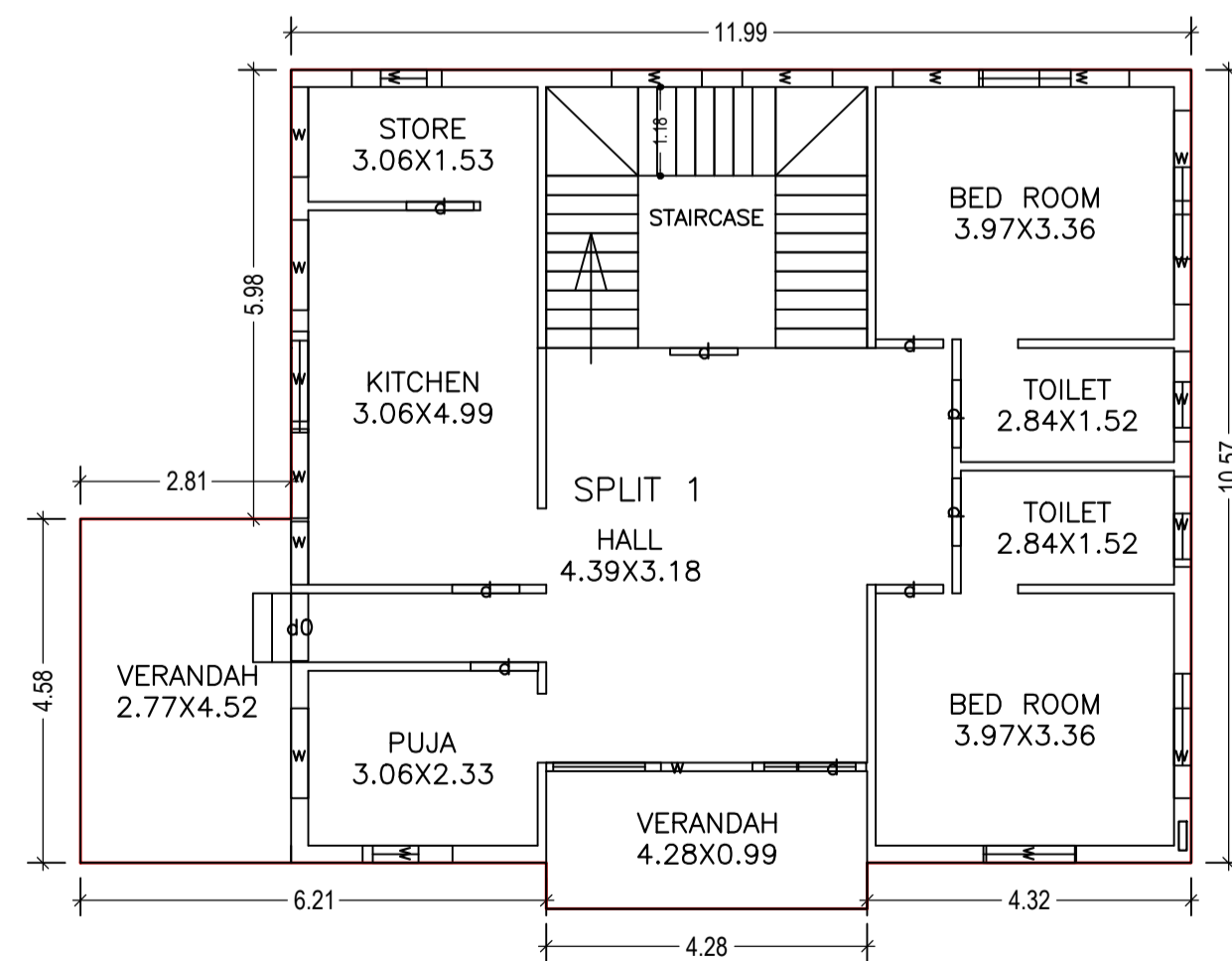
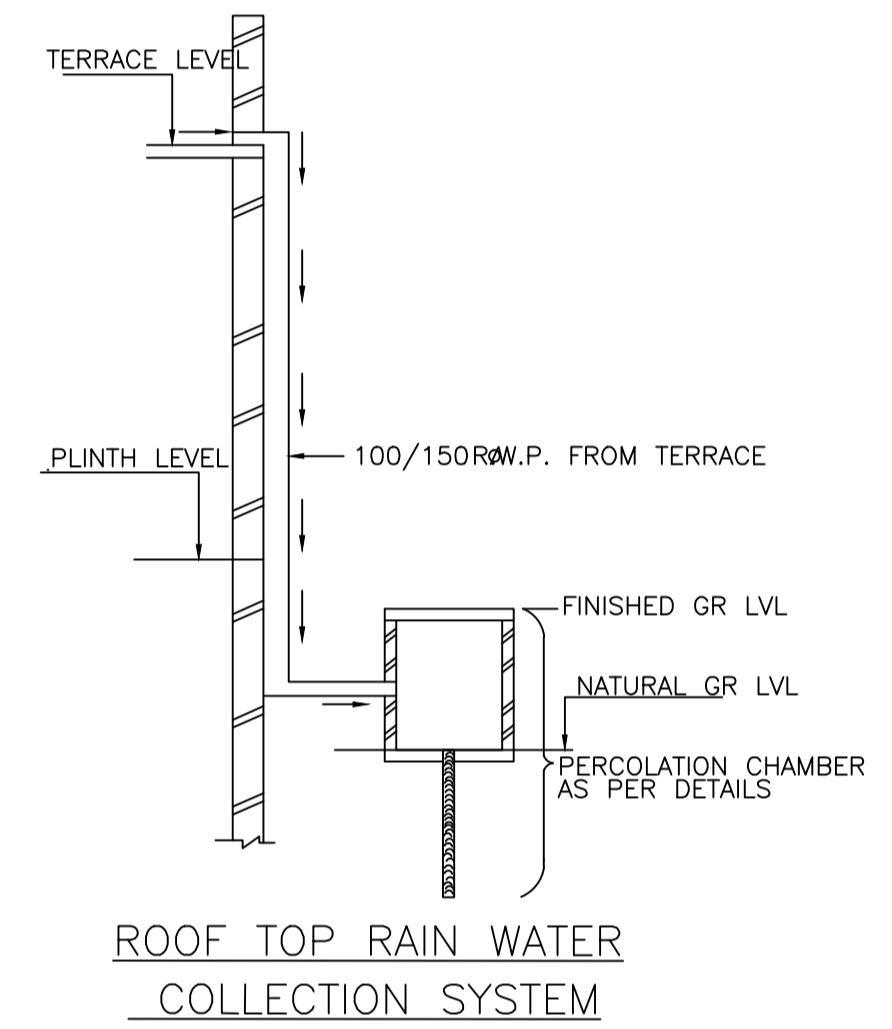
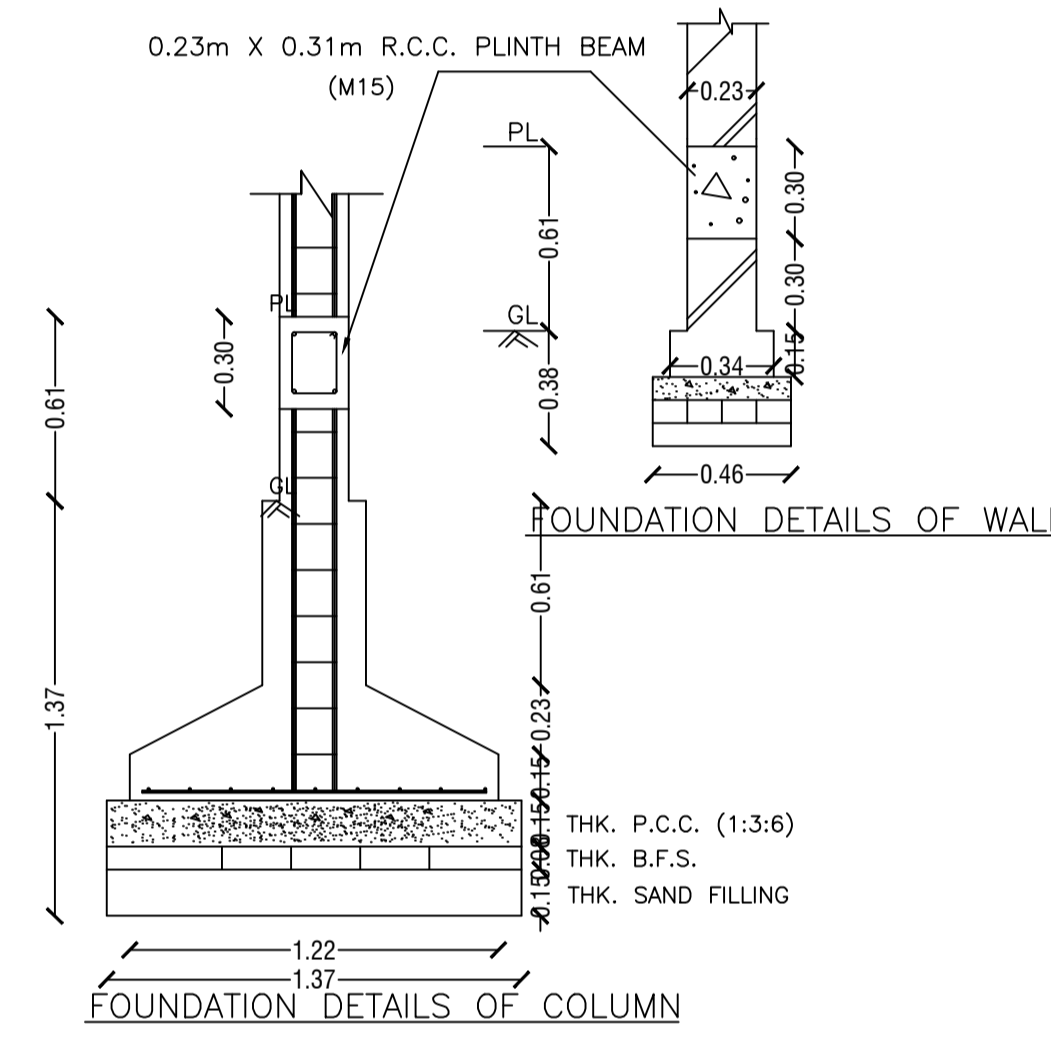
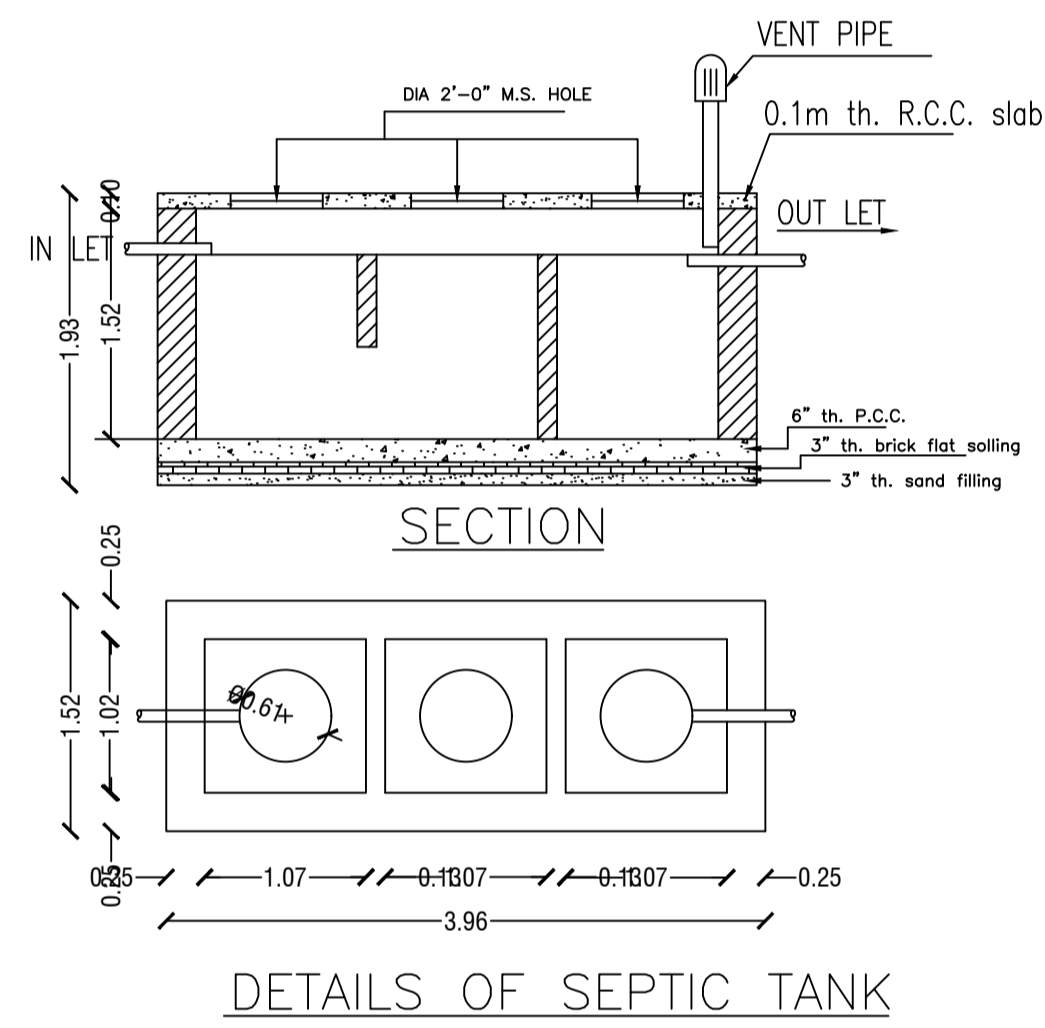
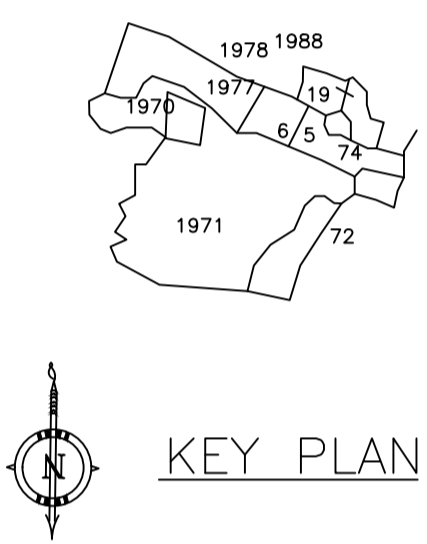
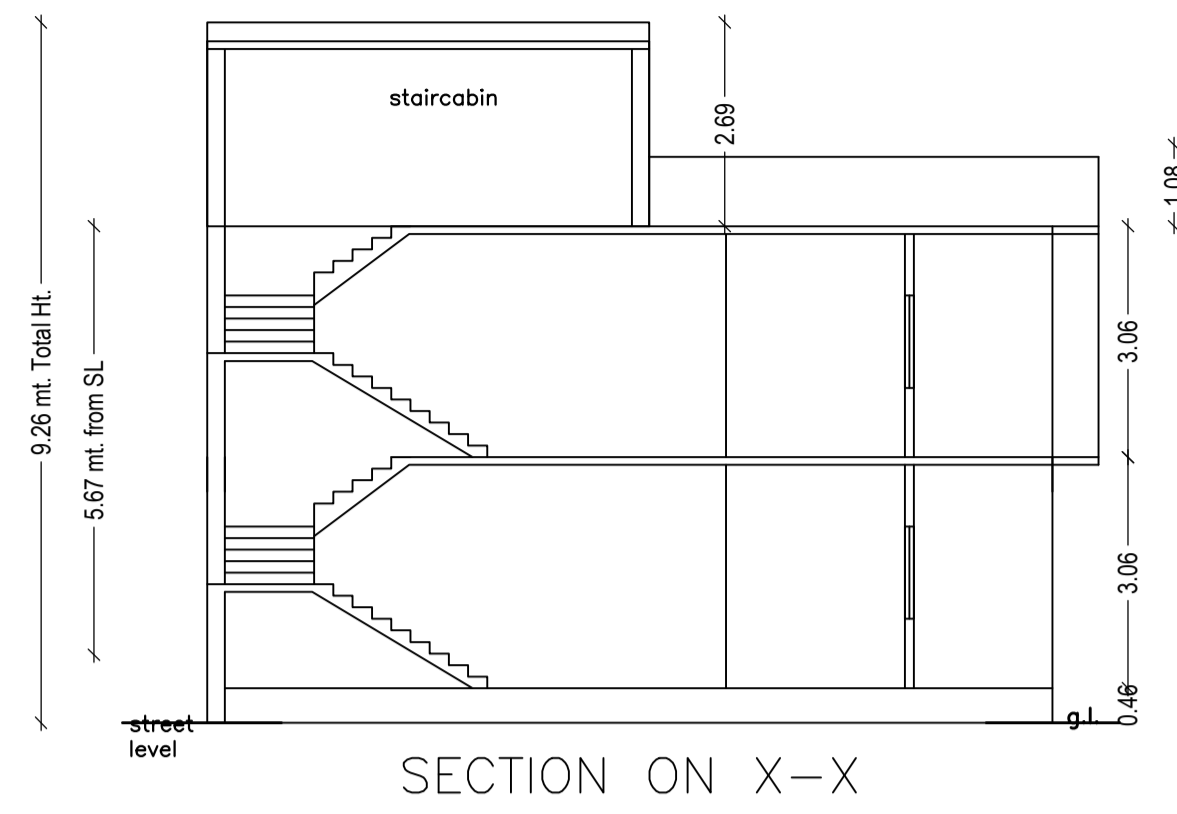
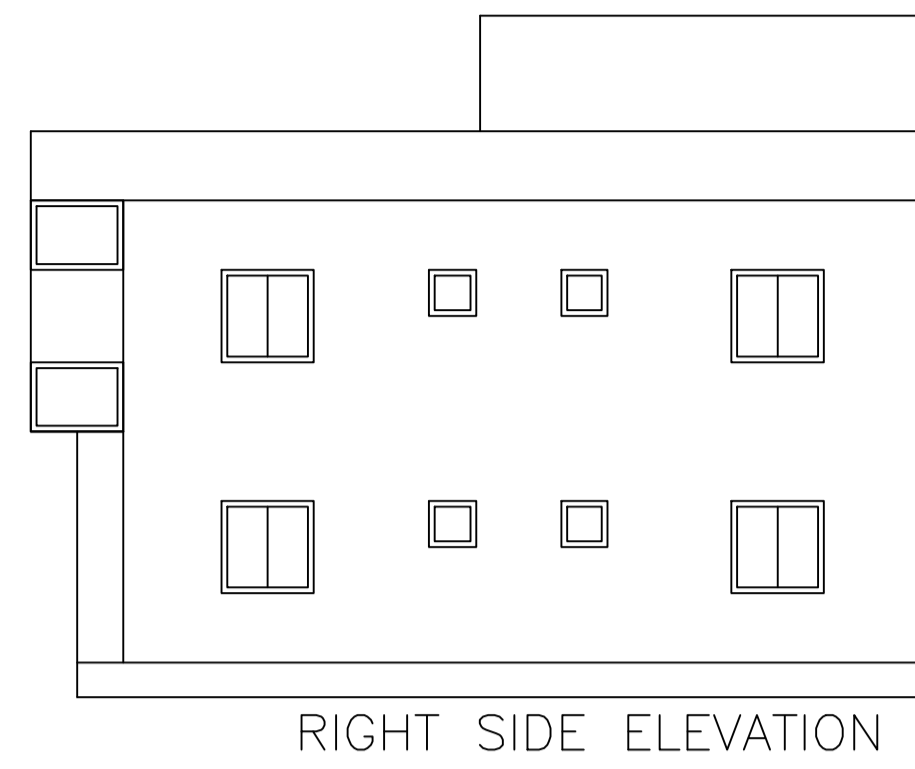
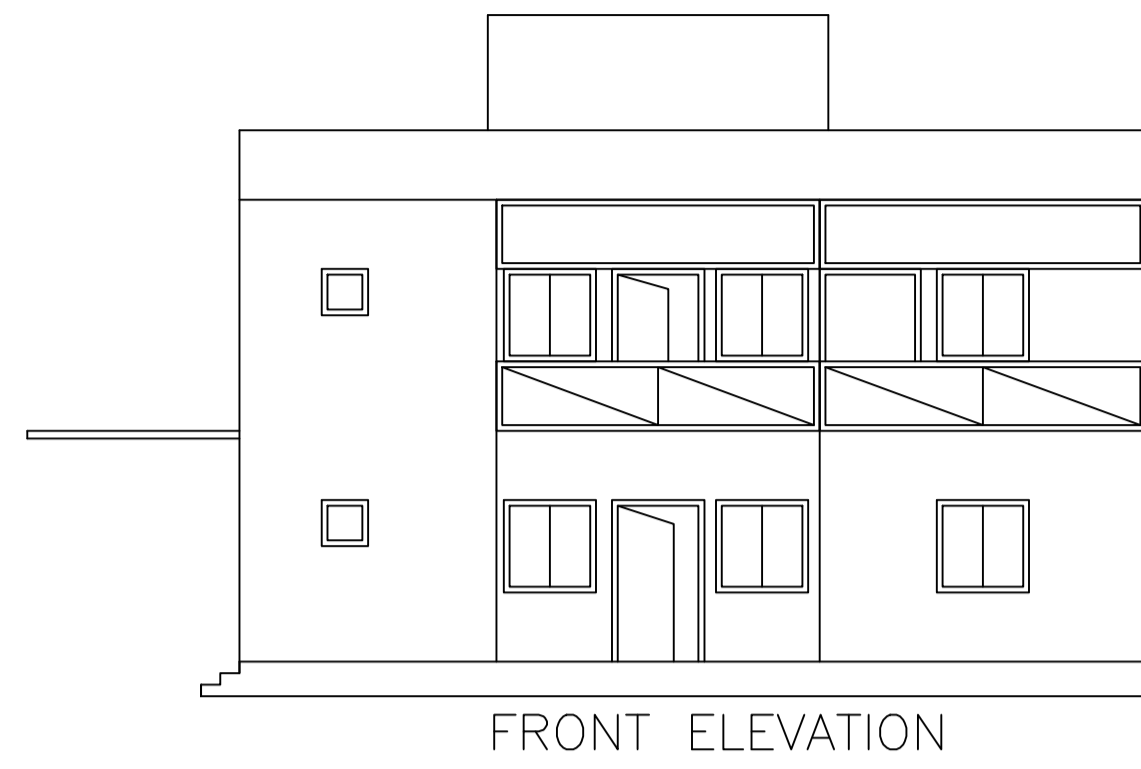

LTP NAME AND SIGNATURE	STRUCTURAL ENG'S NAME AND SIGNATURE	BUILDER NAME AND SIGNATURE
KUMARI RINKU RANI DMC/ENG/0016/2016		