

FRONT ELEVATION

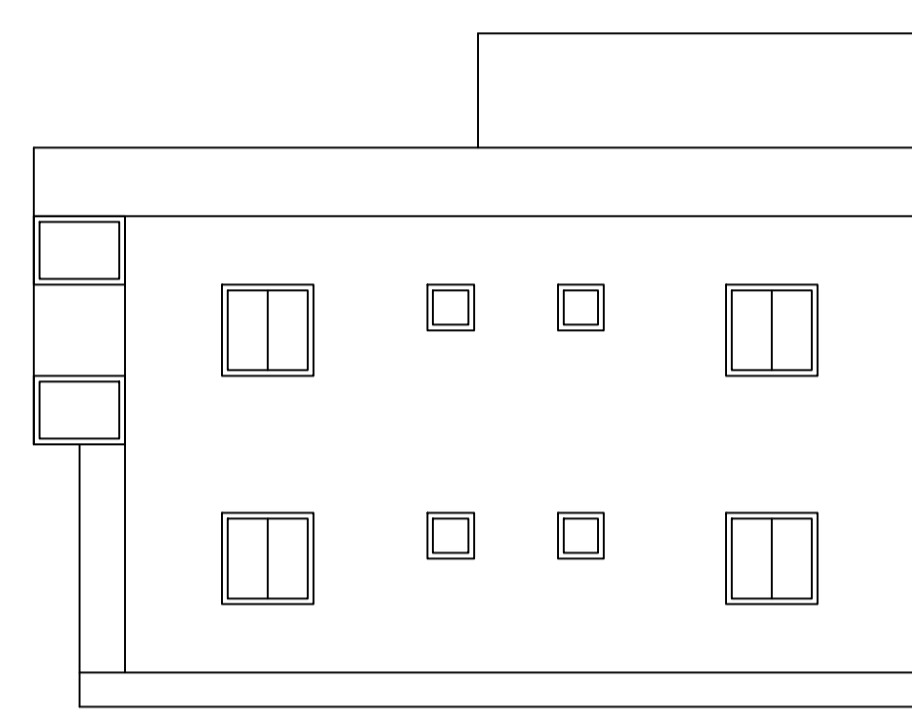

RIGHT SIDE ELEVATION

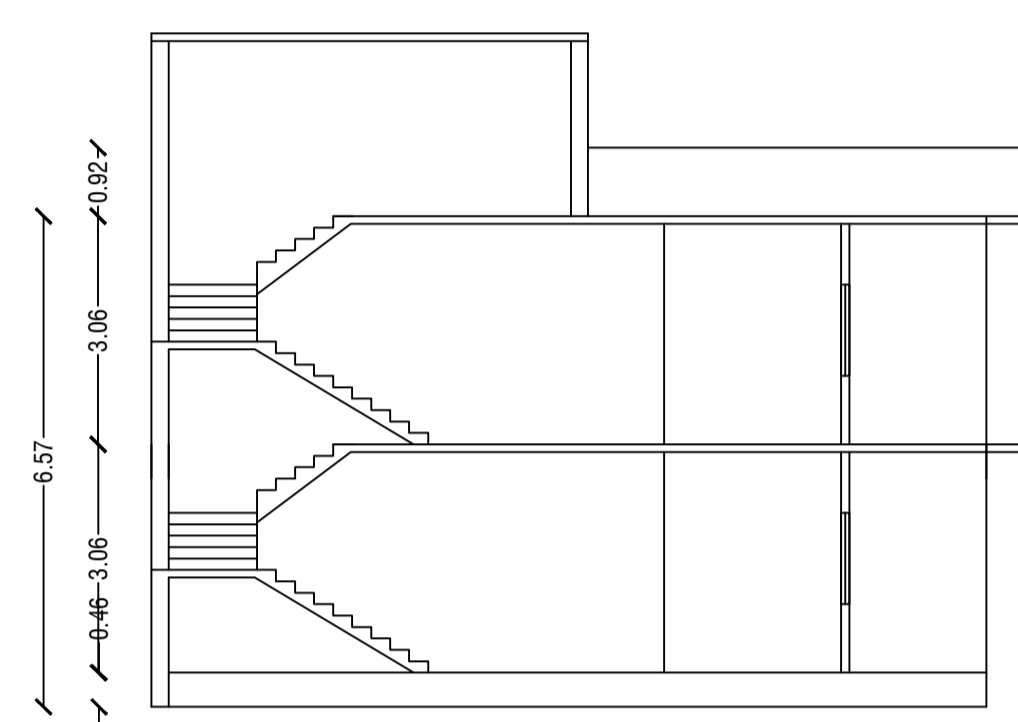

SECTION ON X-X

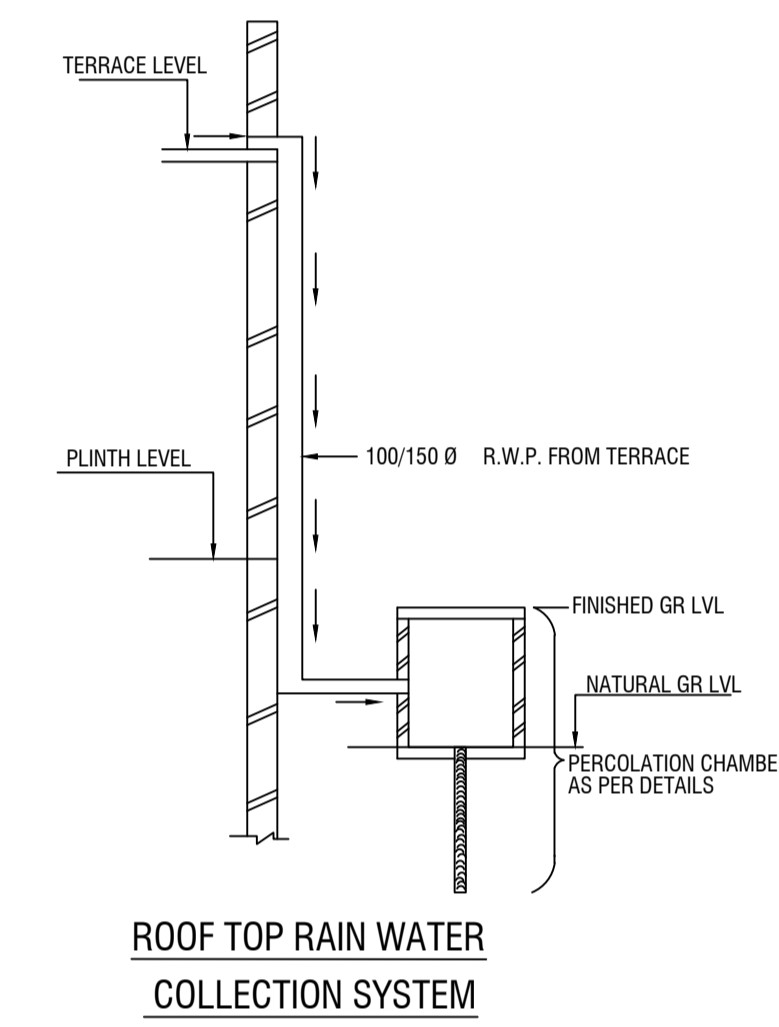

ROOF TOP RAIN WATER COLLECTION SYSTEM

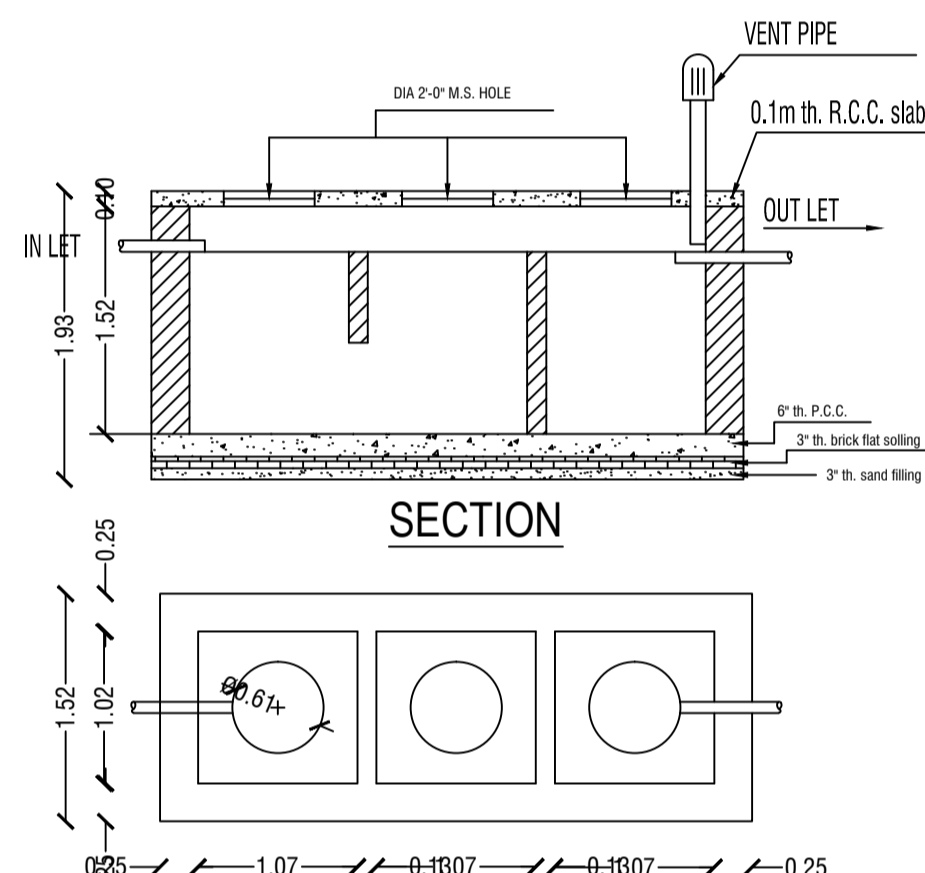
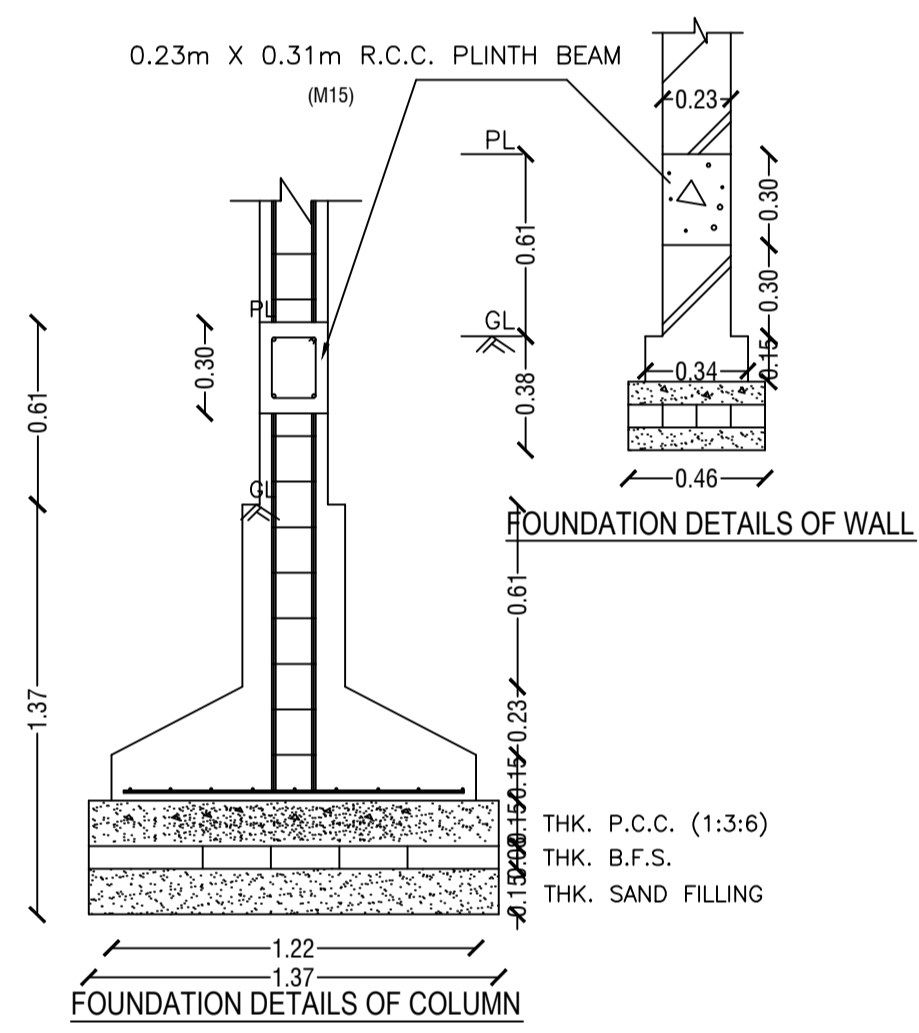
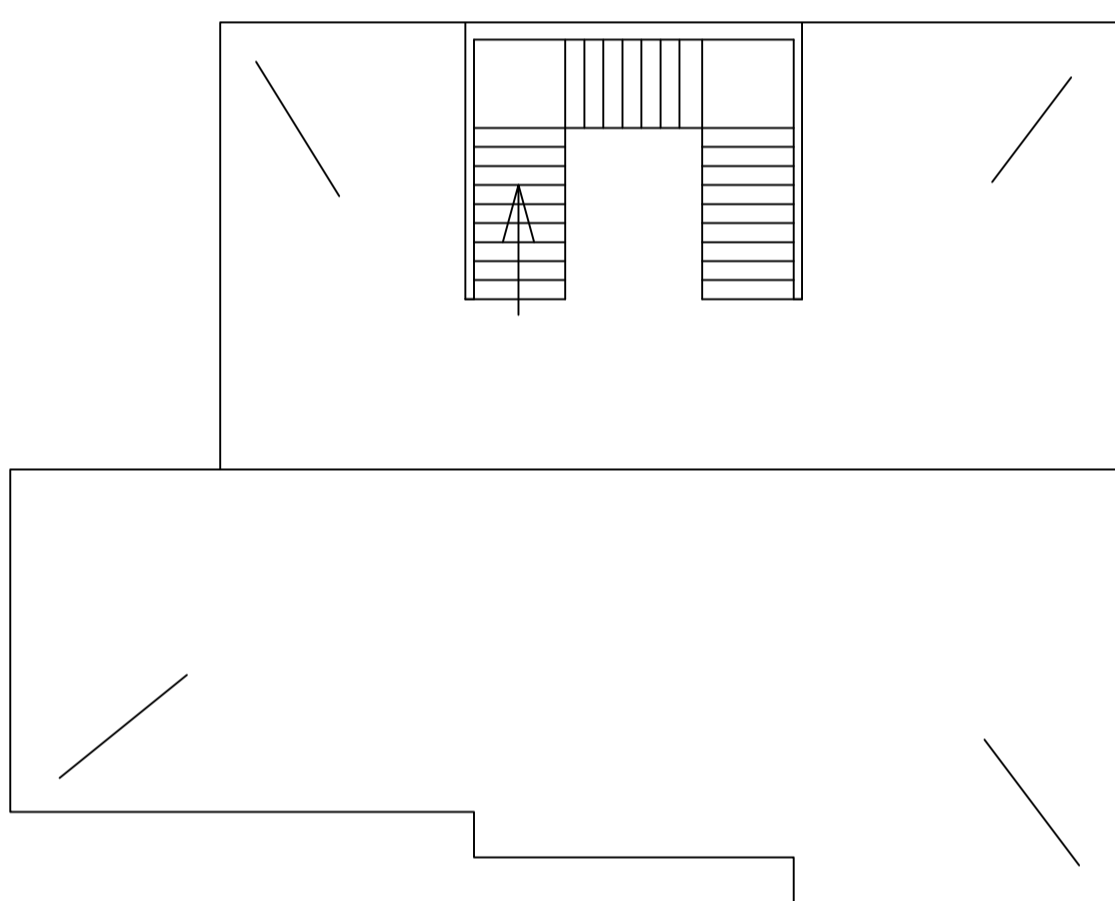

DETAILS OF SEPTIC TANK

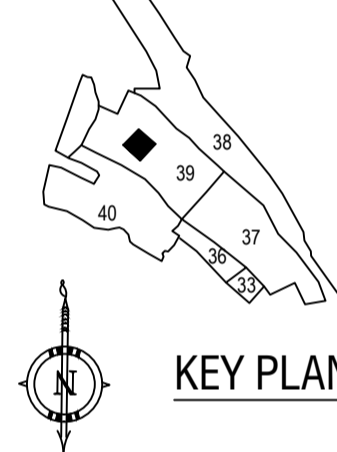

KEY PLAN

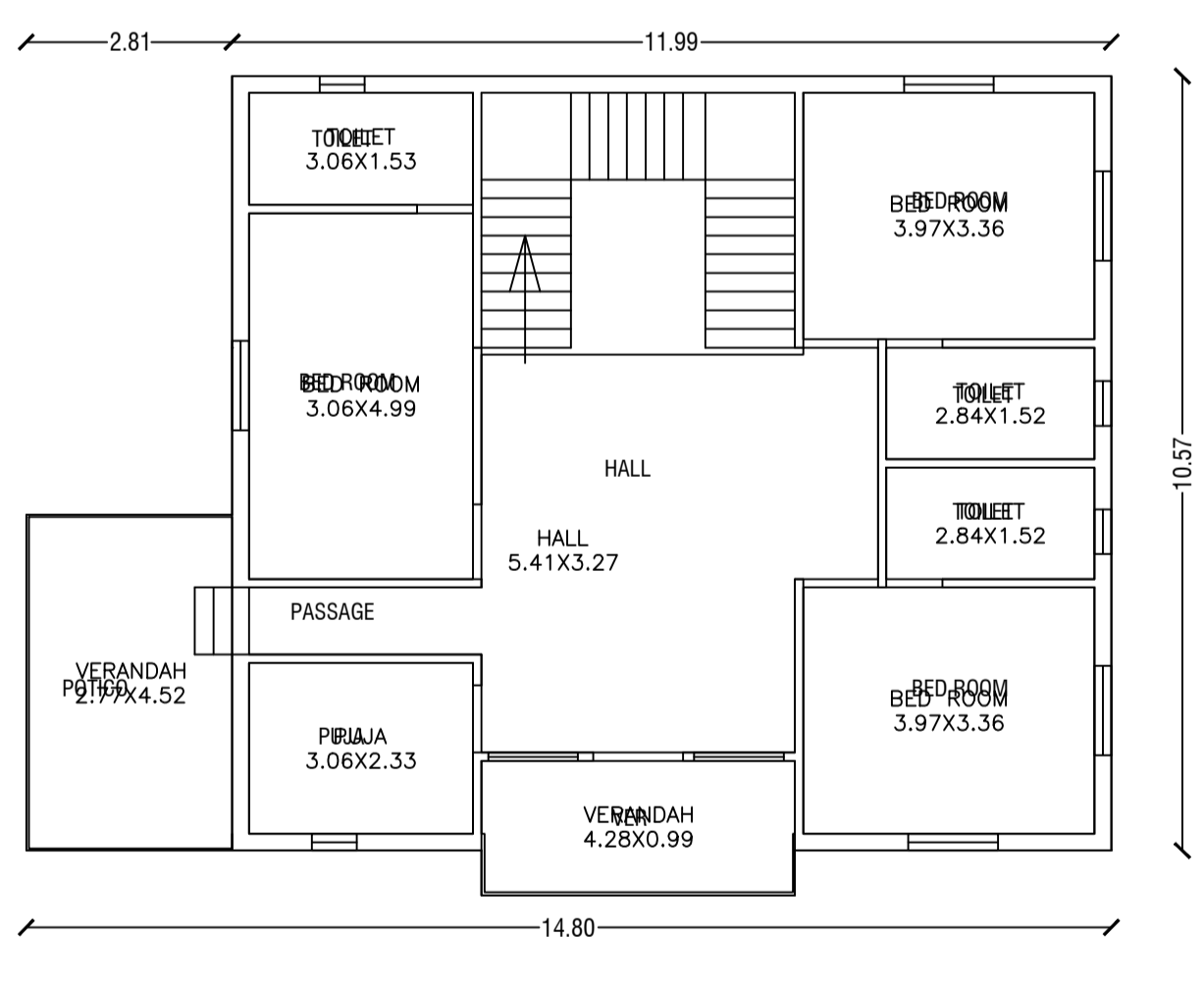

GROUND FLOOR PLAN

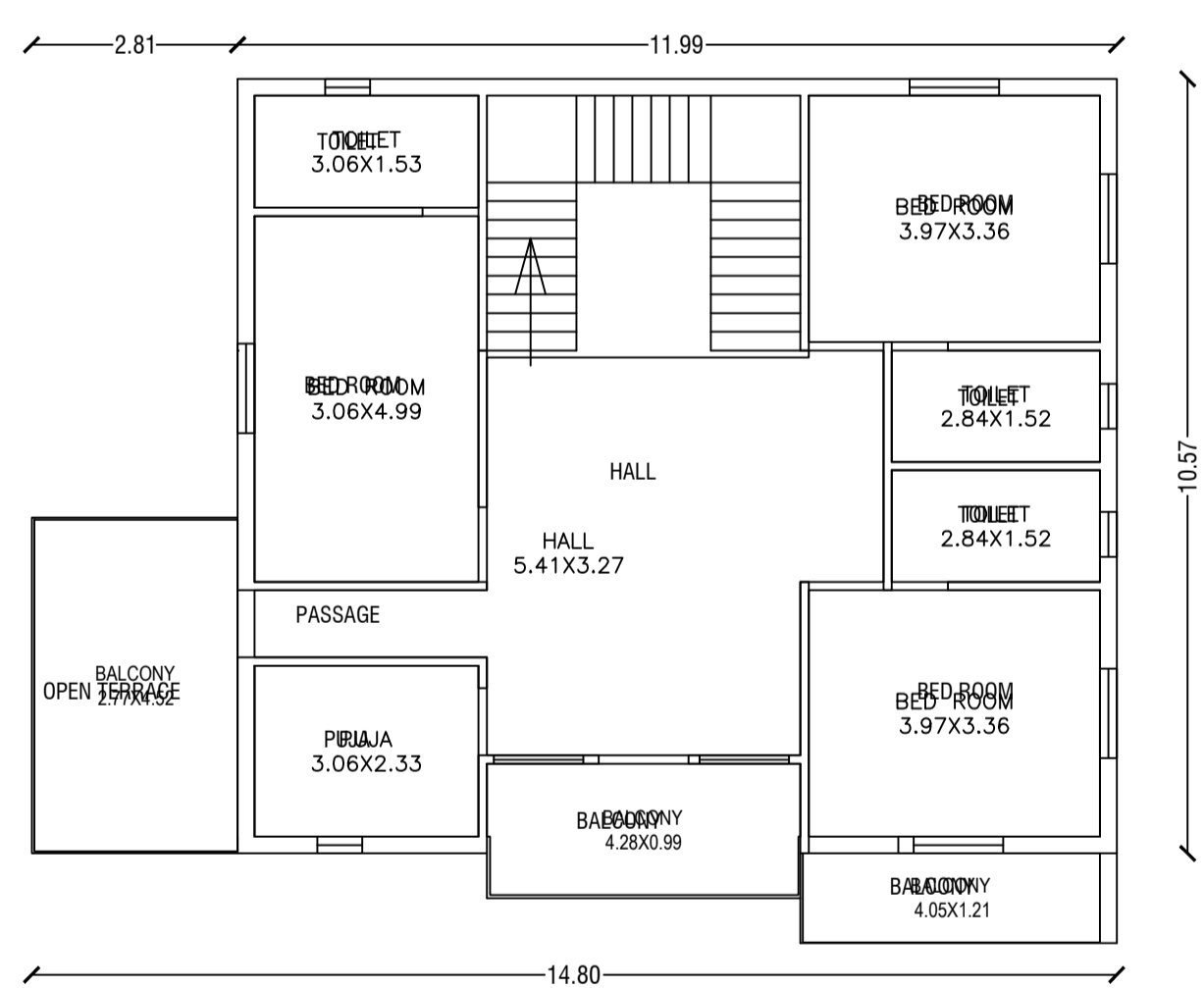

FIRST FLOOR PLAN

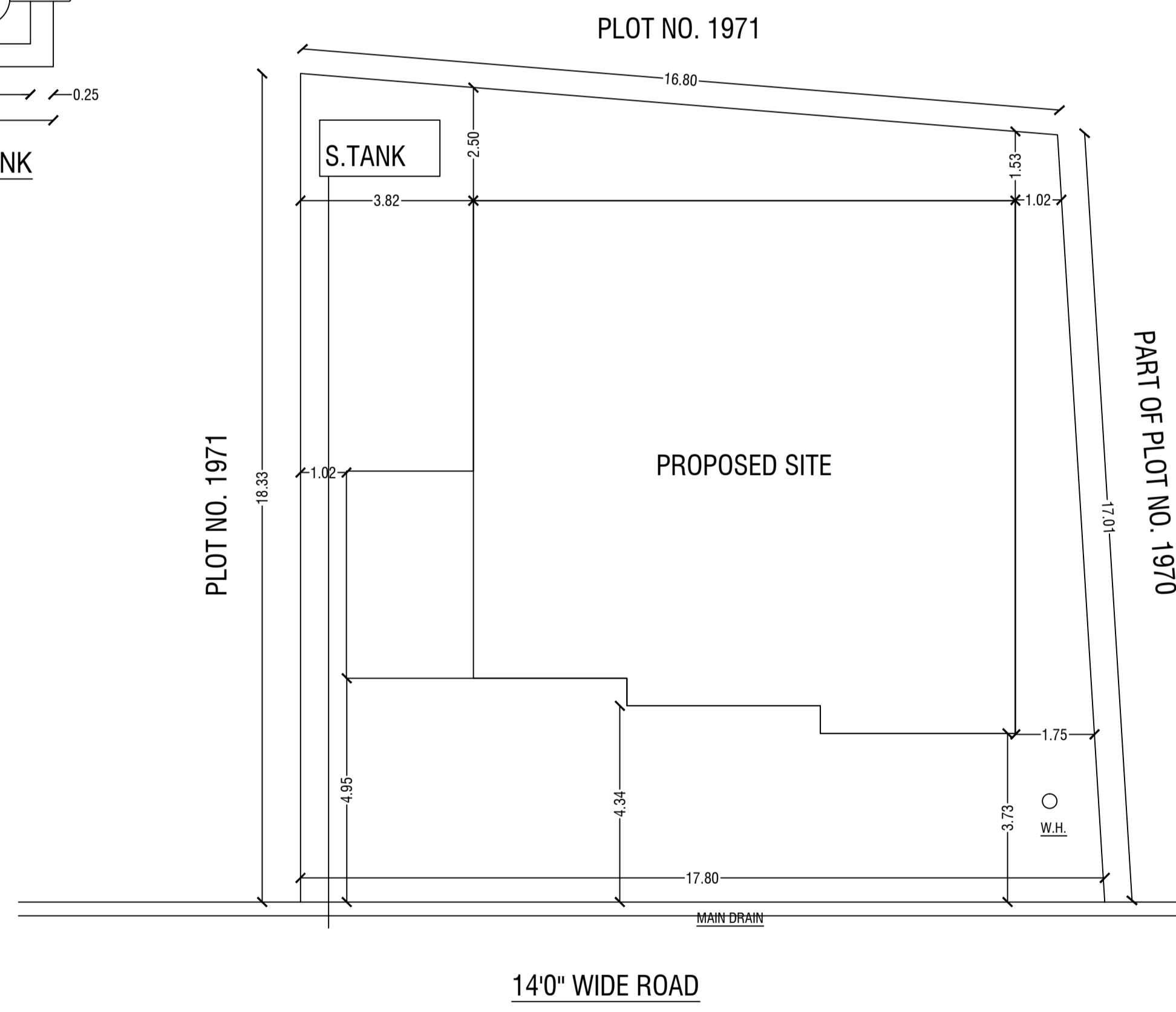

FORMADA USE

SCHEDULE

D1 - 1.07 X 2.13	W - 0.9 x 1.22
D2 - 0.9 X 2.13	W1 - 1.22 x 1.22
D3 - 0.76 x 2.13	W2 - 1.5 x 1.22
CG - 1.22 x 2.13	V - 0.61 x 0.61

NORTH DIRECTION



BRIEF SPECIFICATION

- FOUNDATION - 8" TH P.C.C (1:3:6) FOUNDATION BED AND FIRST CLASS BRICK IN CEMENT MORTAR (1:8) IN FOUNDATION.
- PLINTH - 3" TH P.C.C (1:1.5:3) ALL ROUND ON PLINTH LEVEL.
- FLOORING - 1.5" TH UP S.FLOORING OVER 3"TH P.C.C (1:1.5:3).
- SUPERSTRUCTURE - FIRST CLASS BRICK WORK IN CEMENT MORTAR (1:6).
- SLAB, BEAM & LINTEL - ALL R.C.C WORK (1:1.5:3).
- WOOD WORK - ALL DOOR AND WINDOW FRAMES OF SALWOOD.
- PLASTERING - 1/2" TH CEMENT PLASTER (1:4) ON BOTH SIDE.

AREA STATEMENT

AREA OF THE LAND.....	304.56sqm
GROUND FLOOR PLINTH AREA.....	142.19 S.qm
FIRST FLOOR COVERED AREA.....	147.46sqm
	1441.89 S.Ft.
TOTAL COVERED AREA.....	289.65 sqm
% OF PLINTH AREA.....	92%
F. A. R.....	1.49

TITLE OF DRAWING

PLAN PROPOSED RESIDENTIAL BUILDING OF SMT. NIOTI DEVI W/O SRI. HIRALAL MOHATO OF SARAIHELLA, DHANBAD ON THE PLOT NO. 1970, KHATA NO. 09, MOUZA KOLAKUSUMA NO. 12 IN THE DISTRICT DHANBAD, (JHARKHAND).

SIGNATURE OF OWNER

SIGNATURE OF ENGINEER

SCALE:- 1IN. = 8FT. SHEET:- 1 OF 1