

Proposal Basic Information	
Proposal File No.	DMC/BP/0161/W23/2018
Owner Name	Shankar Prasad Singh and others
Khata No	43
Plot No	1858
Village Name	Kolakusma
Use	Residential
SubUse	Residential Bldg/Apartment

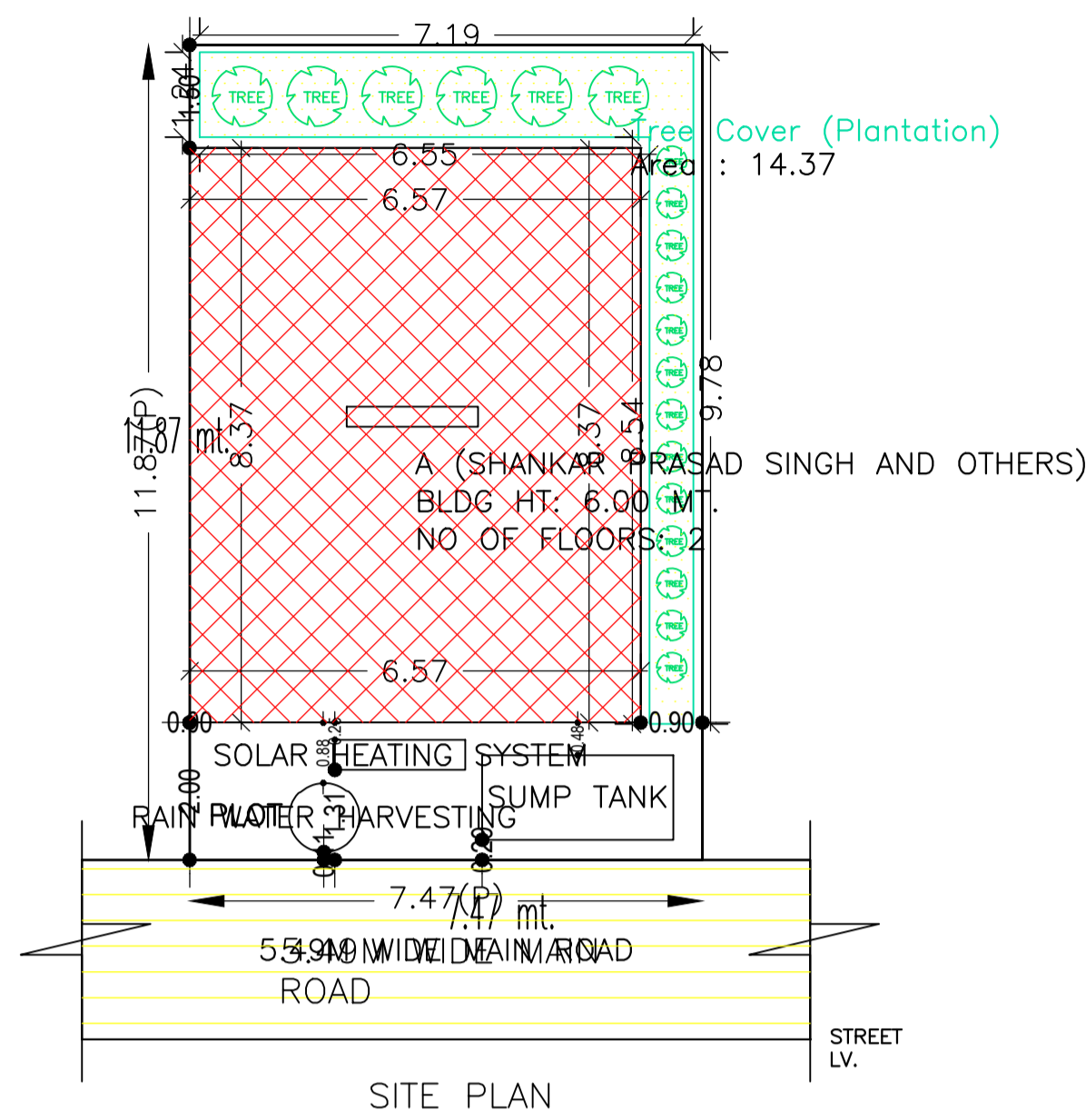

SITE PLAN

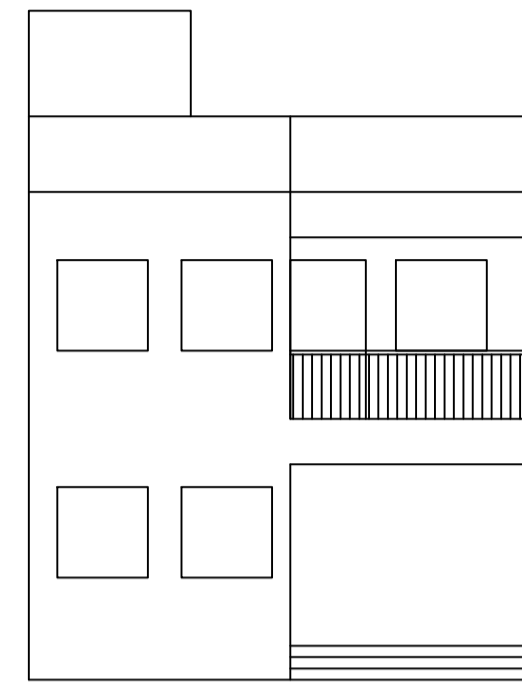

Front Elevation

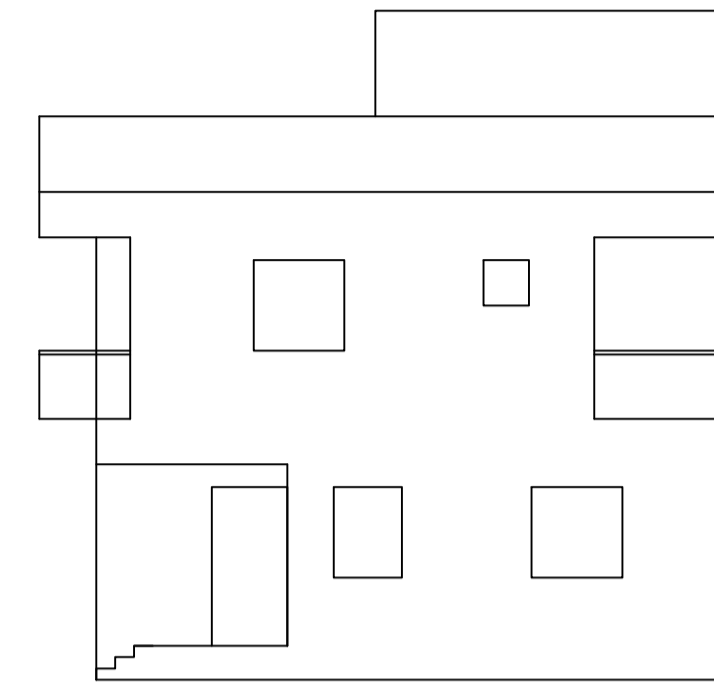

Right Side Elevation

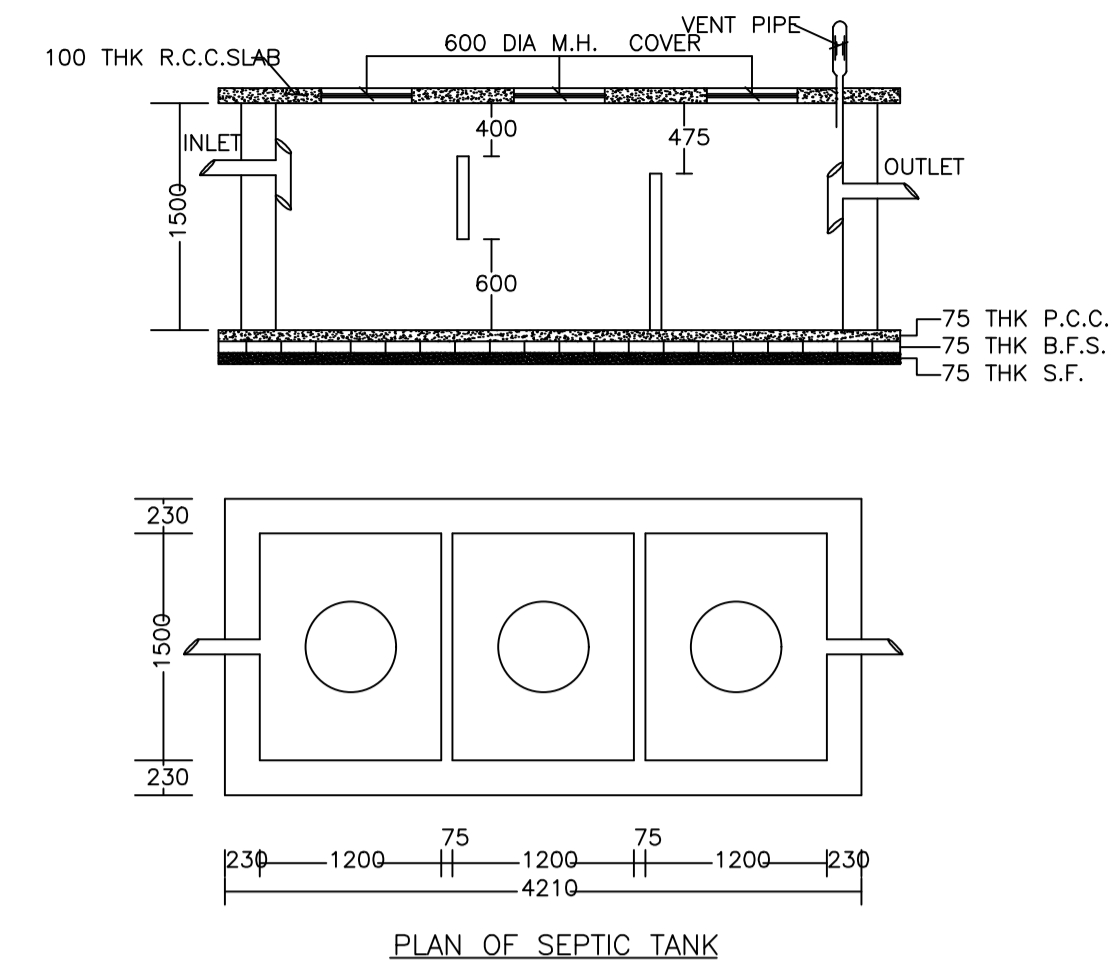

PLAN OF SEPTIC TANK

AREA STATEMENT		VERSION NO. : 1.0.32
DHANBAD MUNICIPAL CORPORATION		VERSION DATE: 10/05/2018
PROJECT DETAIL:		
Region: JHARKHAND URBAN LOCAL BODIES	Plot Use: Residential	
District: DHANBAD	Plot SubUse: Residential Bldg/Apartment	
Authority: DHANBAD MUNICIPAL CORPORATION	Plot/Nearby/Religious/Structure: NA	
Inward No. DMC/BP/0161/W23/2018	Plot/SubPlot No: 1858	
Application Type: General Proposal	North: Plot No - PLOT NO. 1864	
Project Type: Building Permission	South: Road Width - 5.49M WIDE MAIN ROAD	
Nature of Development: New	East: Plot No. - PART OF PLOT NO. 1858	
Location of Development Area: Old Area	West: Plot No. - PART OF PLOT NO. 1858	
AREA DETAILS:		
AREA OF PLOT (Minimum)	(A)	88.65
NET AREA OF PLOT(Gross Plot Area - Deduction from Gross Plot area)	(A-Deductions)	88.65
Deduction for Balance Plot Area(from Gross Plot Area)		
Common Plot		14.37
Total		14.37
BALANCE AREA OF PLOT(Net Plot Area - Recreational/Amenity spaces)	(A-Deductions)	74.28
PLOT AREA FOR COVERAGE(Net Plot Area)	(A-Deductions)	88.65
Plot Area for FAR (Net Plot Area + RoadWidening Area)	(A-Deductions)	88.65
COVERAGE CHECK		
Permissible Coverage area (70.00 %)		62.06
Proposed Coverage Area (62.01 %)		54.97
Total Prop. Coverage Area (62.01 %)		54.97
Balance coverage area (8.00 %)		7.09
FAR CHECK		
Perm. FAR Area (1.80)		159.57
Total Perm. FAR area		159.57
Residential FAR		109.94
Proposed FAR Area		109.94
Total Proposed FAR Area		109.94
Consumed FAR (Factor)		1.24
Balance FAR Area		49.63
BUILT UP AREA CHECK		
Total Proposed BuiltUp Area		109.94
ARCHITECT (Regd)	PIYUSH KANTI SINGH	
ENGINEER (Regd)		
SUPERVISOR (Regd)		
OWNER (Regd)	Shankar Prasad Singh and others	
DEVELOPMENT AUTHORITY		LOCAL BODY

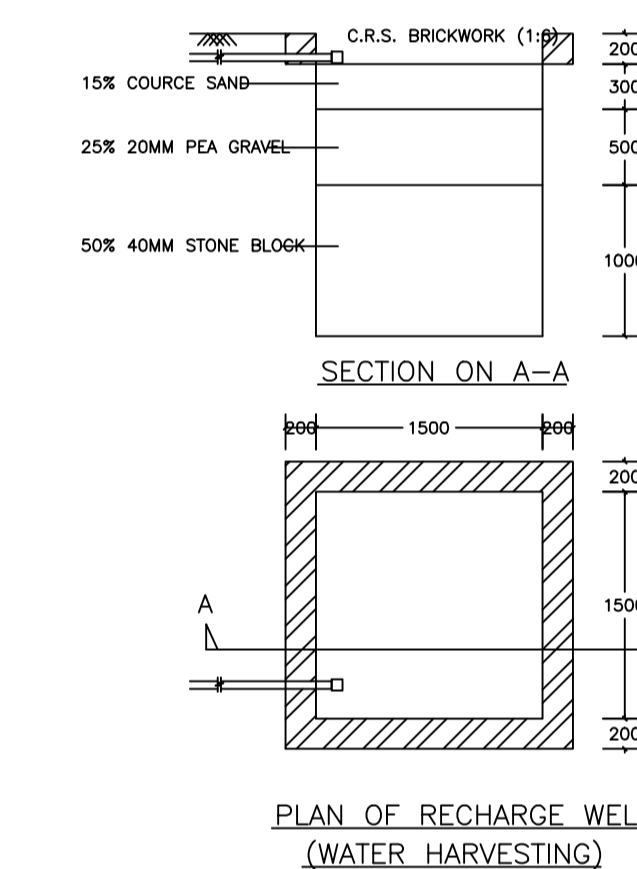

PLAN OF RECHARGE WELL (WATER HARVESTING)

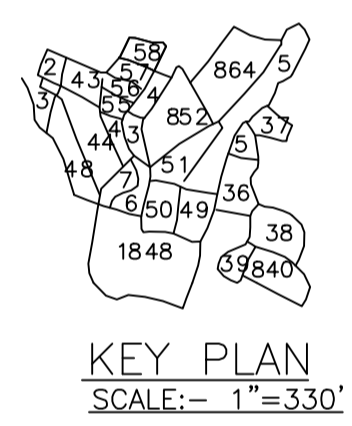

KEY PLAN SCALE:- 1"=330'

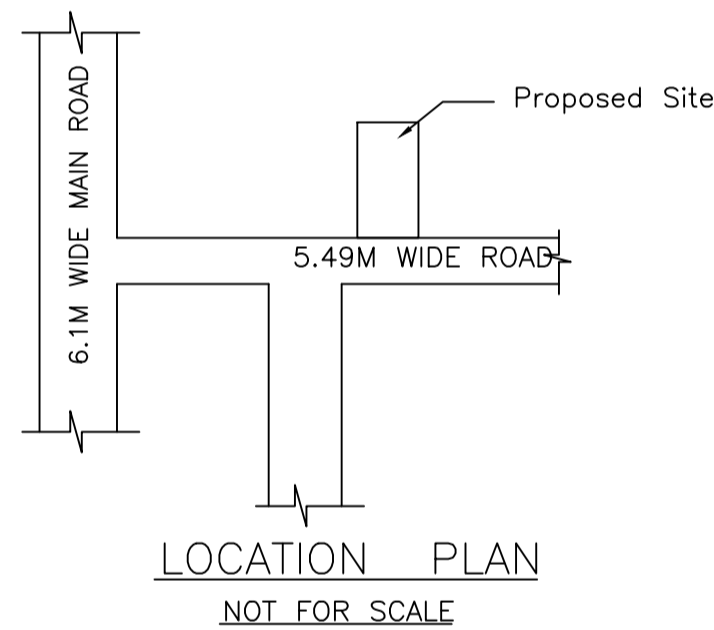

LOCATION PLAN NOT FOR SCALE

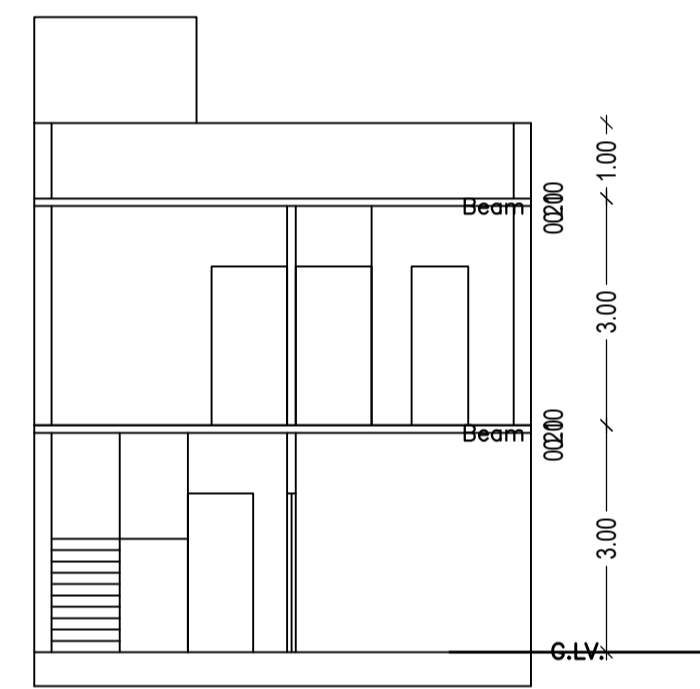

Section on Y-Y

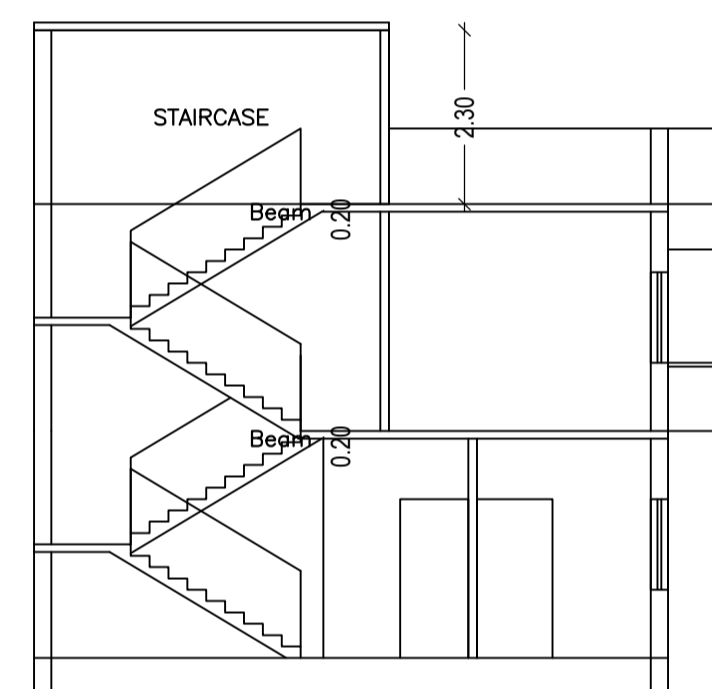

Section on X-X

UnitBUA Table for Building :A (SHANKAR PRASAD SINGH AND OTHERS)

FLOOR	Name	UnitBUA Type	UnitBUA Area	Carpet Area	No. of Rooms	No. of Tenement
GROUND FLOOR PLAN	SPLIT 1	FLAT	109.94	105.39	5	1
FIRST FLOOR PLAN	SPLIT 1	FLAT	0.00	0.00	5	0
Total:	-	-	109.94	105.39	10	1

Building :A (SHANKAR PRASAD SINGH AND OTHERS)

Floor Name	Total Built Up Area (Sq.mt.)	Proposed FAR Area (Sq.mt.) Resi.	Total FAR Area (Sq.mt.)	Total Consumed Additional FAR Area (Sq.mt.)	Trmt (No.)
Ground Floor	54.97	54.97	54.97	54.97	01
First Floor	54.97	54.97	54.97	54.97	00
Terrace Floor	0.00	0.00	0.00	0.00	00
Total :	109.94	109.94	109.94	109.94	01
Total Number of Same Buildings :	1				
Total :	109.94	109.94	109.94	109.94	01

SCHEDULE OF DOOR:

BUILDING NAME	NAME	LENGTH	HEIGHT	NOS
A (SHANKAR PRASAD SINGH AND OTHERS)	D2	0.75	2.10	03
A (SHANKAR PRASAD SINGH AND OTHERS)	D1	0.90	2.10	02
A (SHANKAR PRASAD SINGH AND OTHERS)	D	1.00	2.10	05

SCHEDULE OF WINDOW/VENTILATION:

BUILDING NAME	NAME	LENGTH	HEIGHT	NOS
A (SHANKAR PRASAD SINGH AND OTHERS)	V	0.60	0.60	03
A (SHANKAR PRASAD SINGH AND OTHERS)	W1	0.90	1.20	03
A (SHANKAR PRASAD SINGH AND OTHERS)	W	1.20	1.20	07

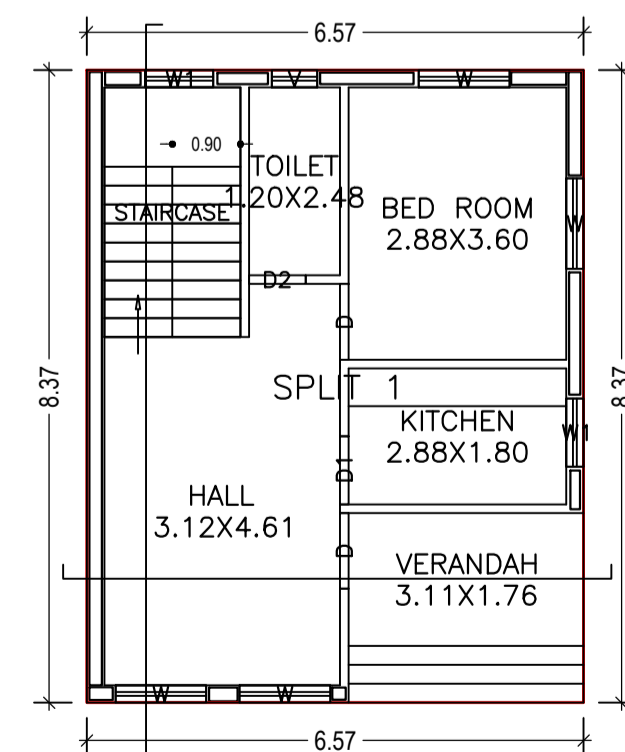

GROUND FLOOR PLAN (Proposed) (SCALE 1:100)

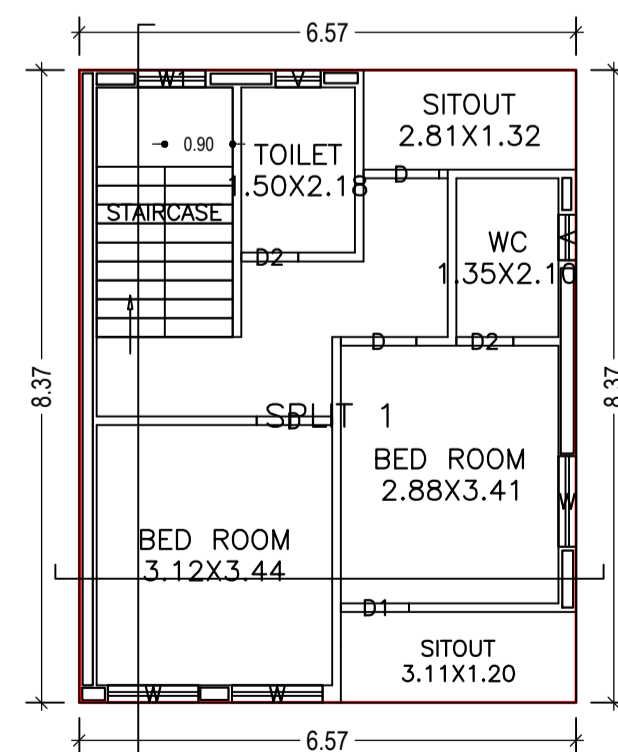

FIRST FLOOR PLAN (Proposed) (SCALE 1:100)

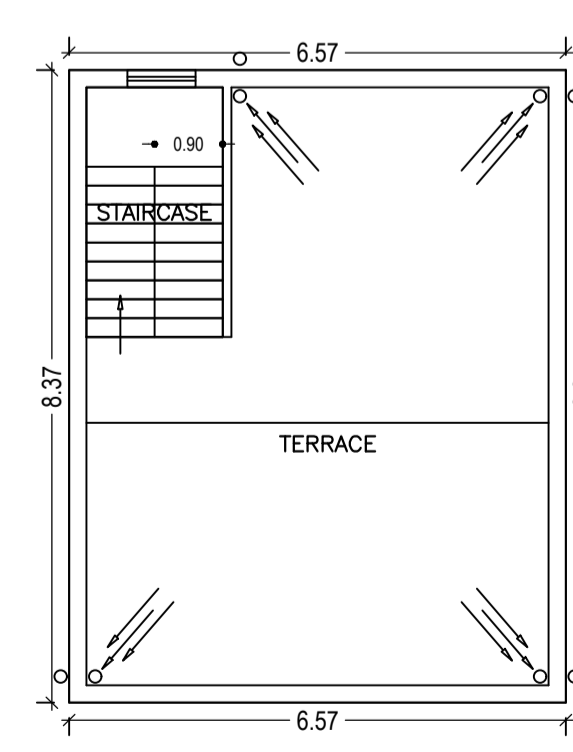

TERRACE FLOOR PLAN (SCALE 1:100)

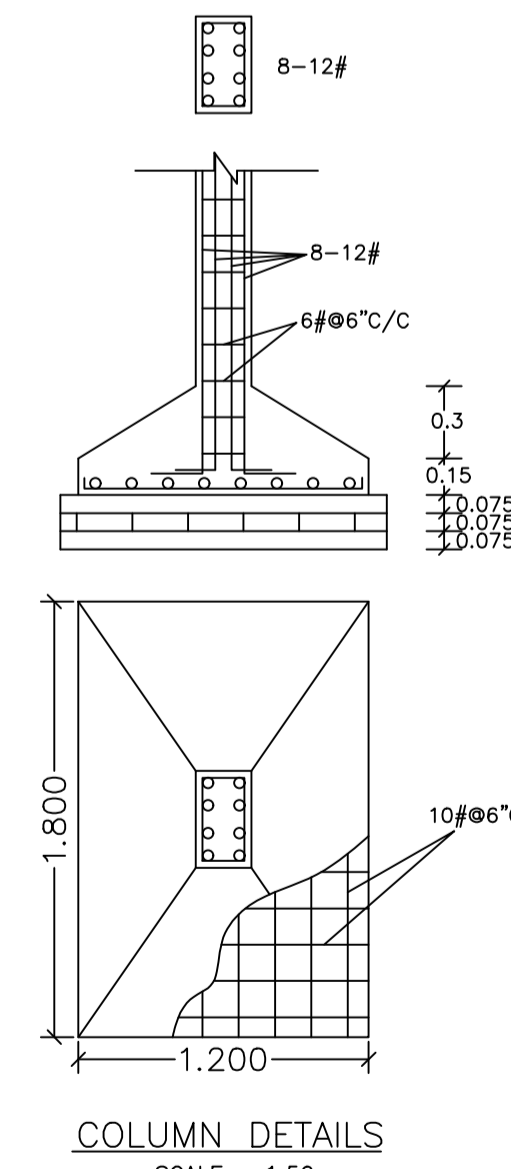

COLUMN DETAILS SCALE:- 1:50

COLOR INDEX	
PLOT BOUNDARY	Black
ABUTTING ROAD	Red
PROPOSED CONSTRUCTION	Green
COMMON PLOT	Yellow
ROAD WIDENING AREA	Blue
EXISTING (To be retained)	Orange
EXISTING (To be demolished)	Grey

Buildingwise Floor FAR Details

Floor Name	Building Name A (SHANKAR PRASAD SINGH AND OTHERS)		Total	
	Proposed Built Up Area (Sq.mt.)	Proposed FAR Area (Sq.mt.)	Total Proposed Built Up Area (Sq.mt.)	Total FAR Area (Sq.mt.)
Ground Floor	54.97	54.97	54.97	54.97
First Floor	54.97	54.97	54.97	54.97
Terrace Floor	0.00	0.00	0.00	0.00
Total :	109.94	109.94	109.94	109.94

Building USE/SUBUSE Details

Building Name	Building Use	Building SubUse	Building Structure
A (SHANKAR PRASAD SINGH AND OTHERS)	Residential	Residential Bldg/Apartment	Non-Highrise

FAR & Tenement Details (Table 4c-1)

Building	No. of Same Bldg	Total Built Up Area (Sq.mt.)	Proposed FAR Area (Sq.mt.) Resi.	Total FAR Area (Sq.mt.)	Total Consumed Additional FAR Area (Sq.mt.)	Trmt (No.)
A (SHANKAR PRASAD SINGH AND OTHERS)	1	109.94	109.94	109.94	109.94	01
Grand Total :	1	109.94	109.94	109.94	109.94	01

LTP NAME AND SIGNATURE	STRUCTURAL ENG'S NAME AND SIGNATURE	BUILDER NAME AND SIGNATURE	DIGITAL SIGNATURE
PIYUSH KANTI SINGH DMC/ENG/0020/2016			

Proposal Basic Information

Proposal File No.	DMC/BP/0161/W23/2018
Owner Name	Shankar Prasad Singh and others
Khata No	43
Plot No	1858
Village Name	Kolakusma
Use	Residential
SubUse	Residential Bldg/Apartment

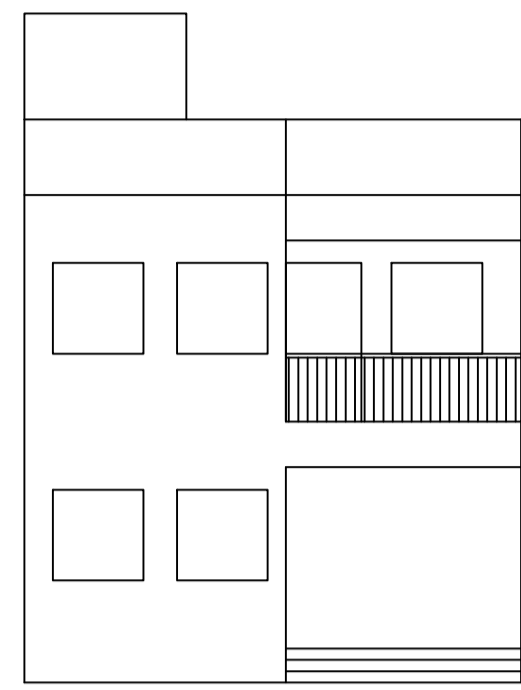

Front Elevation

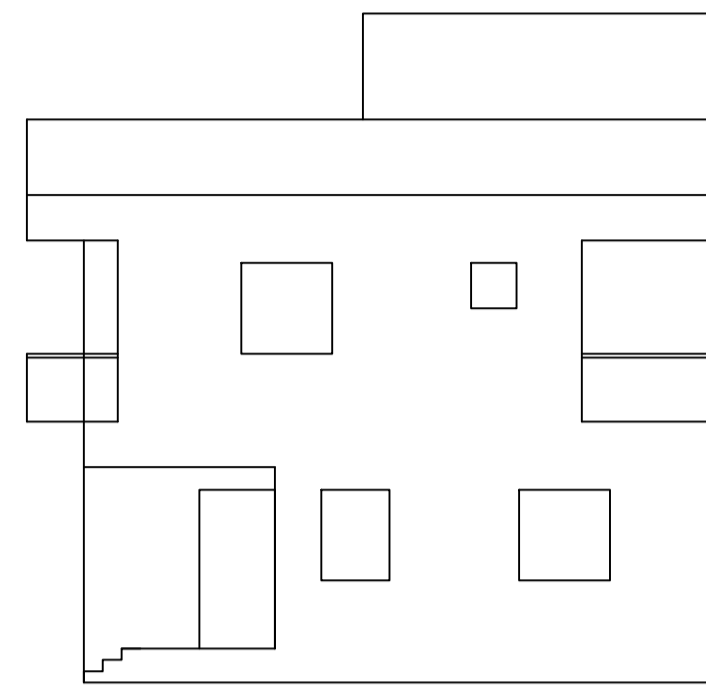

Right Side Elevation

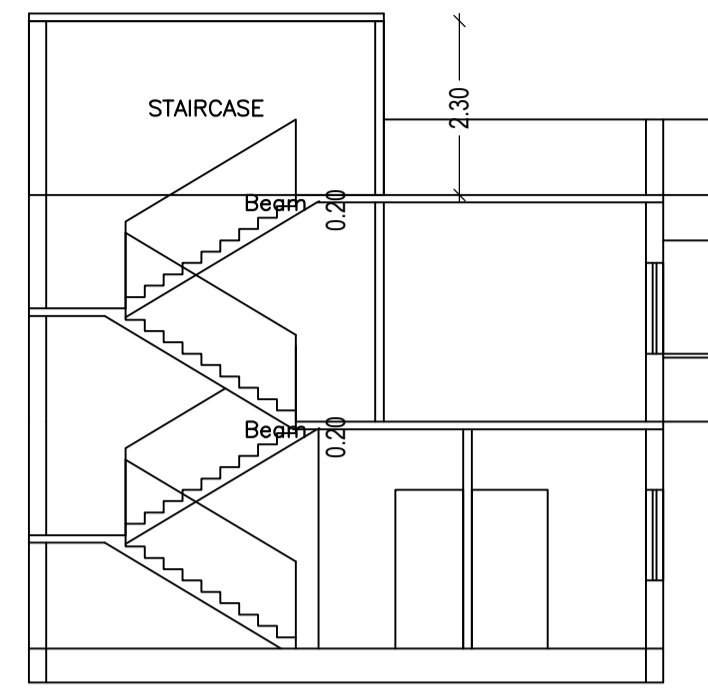

Section on X-X

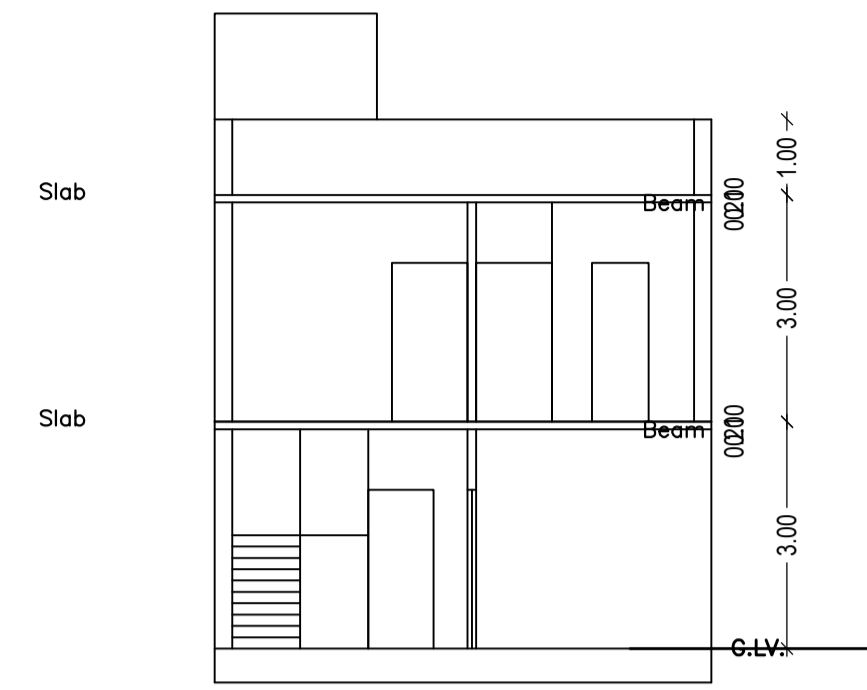

Section on Y-Y

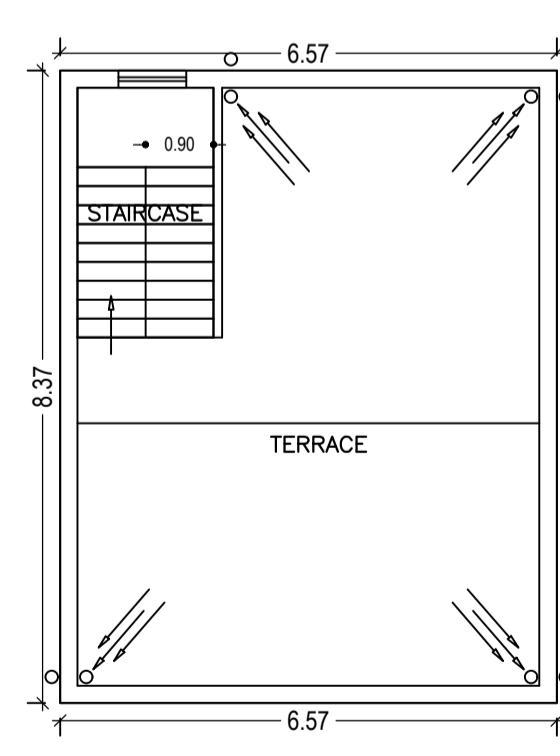
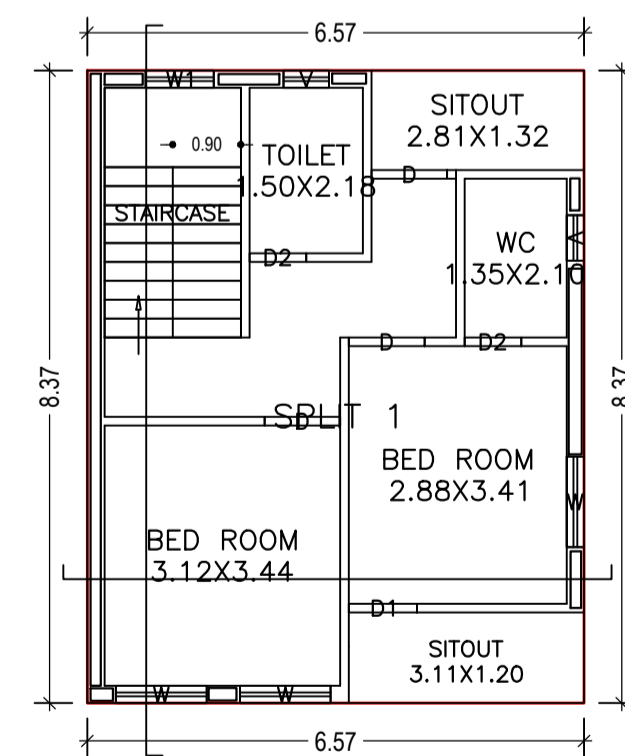
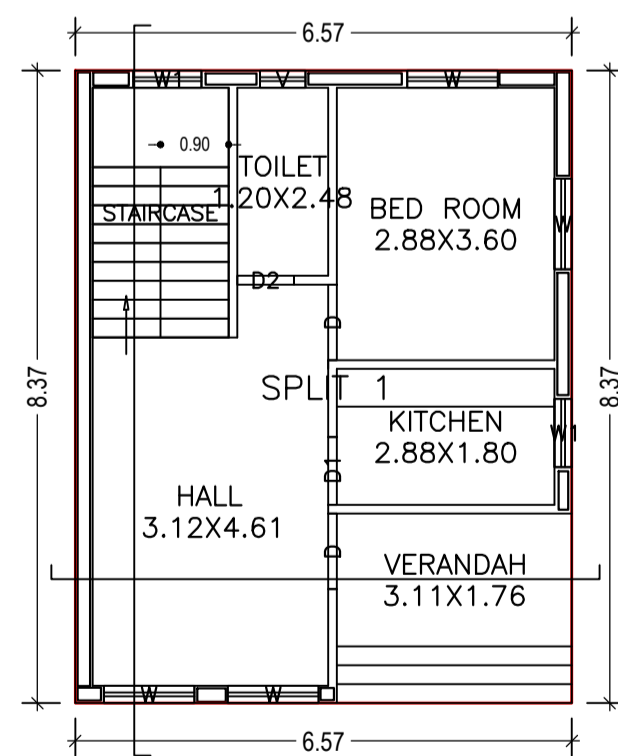
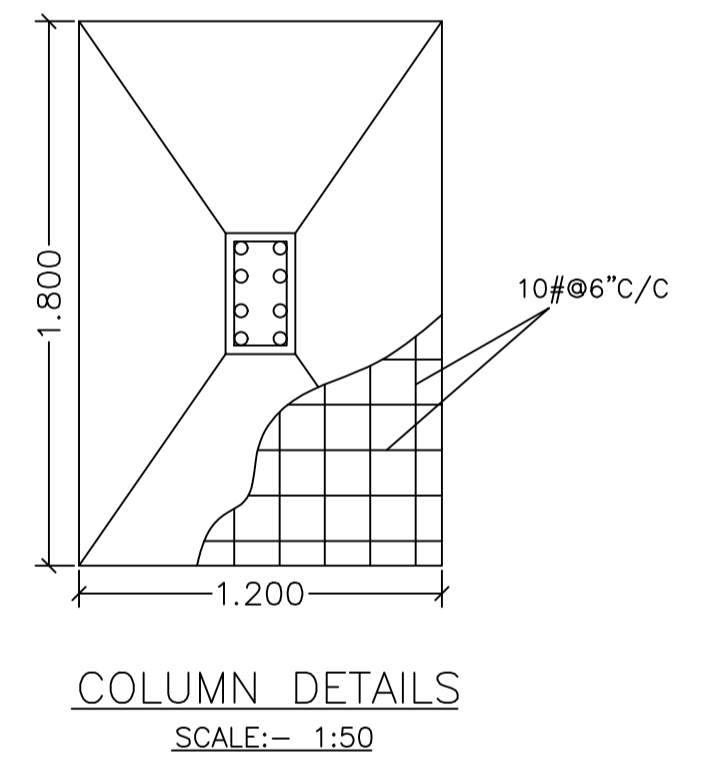
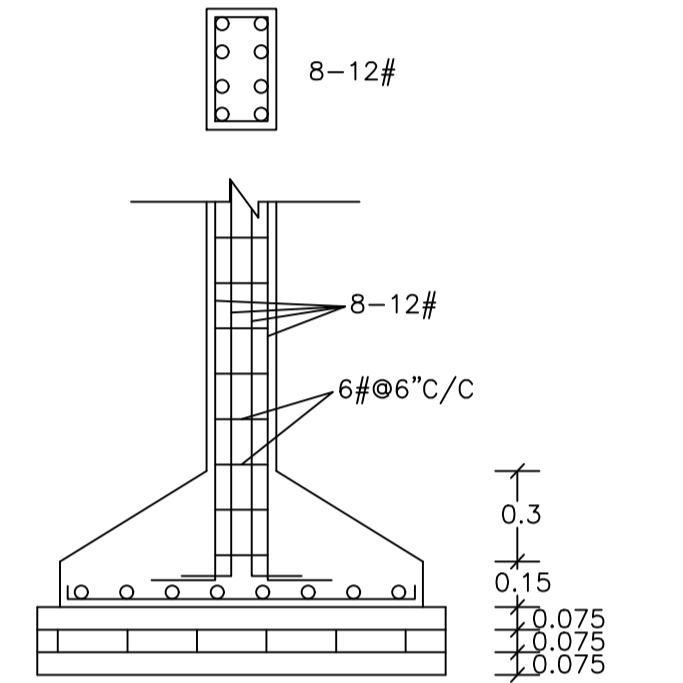
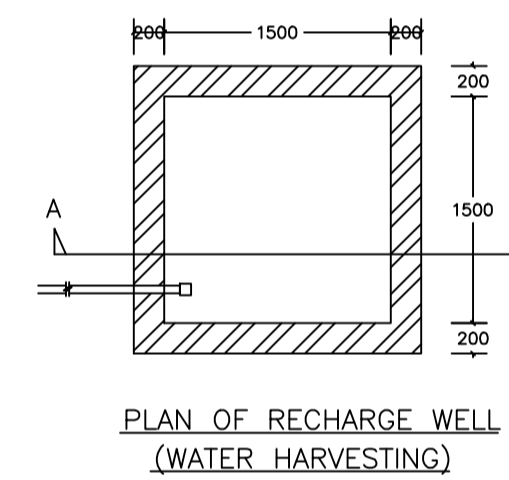
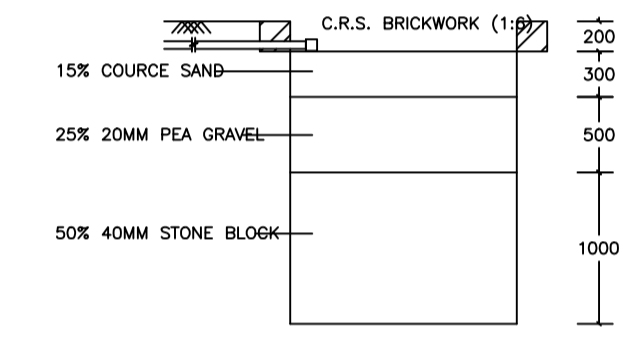
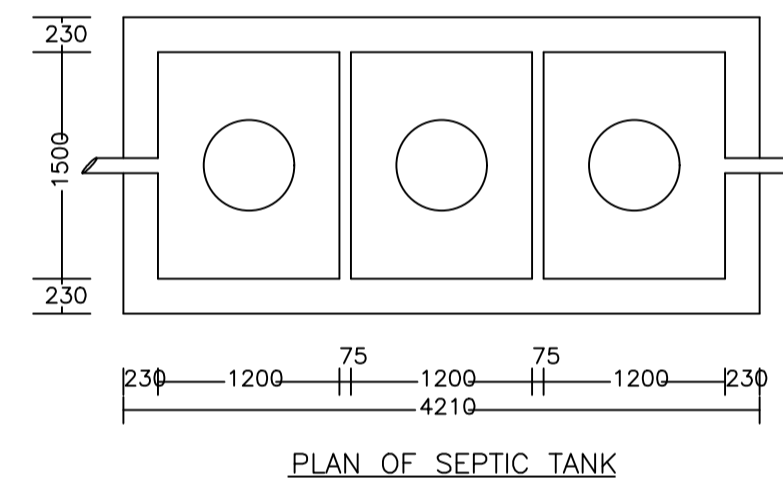
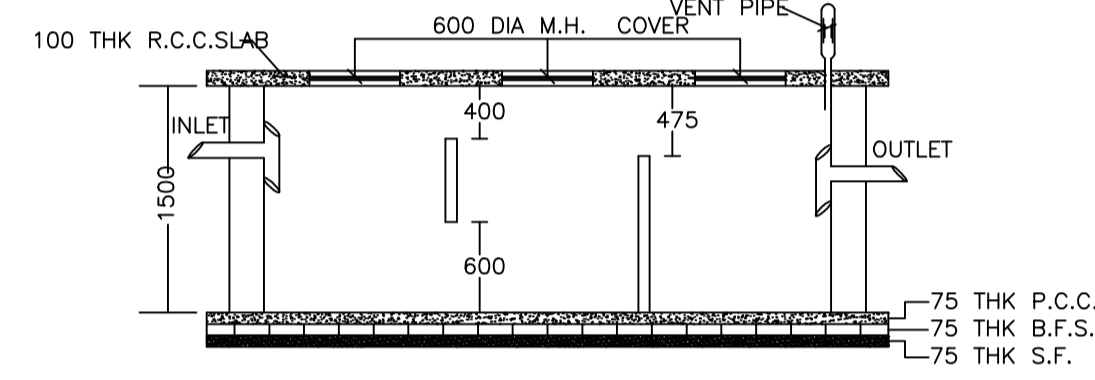
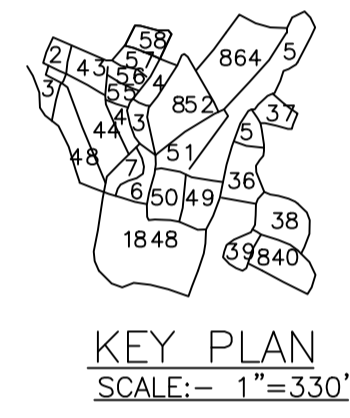
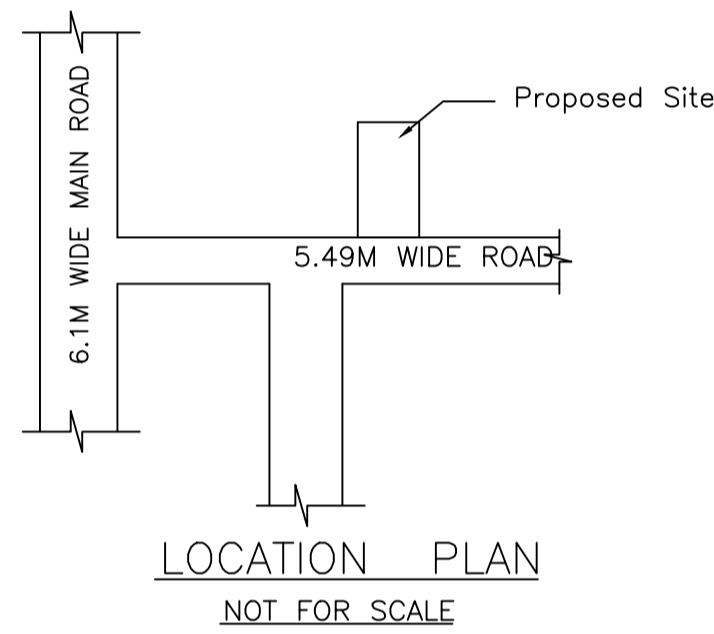

LTP NAME AND SIGNATURE	STRUCTURAL ENG'S NAME AND SIGNATURE	BUILDER NAME AND SIGNATURE	DIGITAL SIGNATURE
PIYUSH KANTI SINGH DMC/ENG/0020/2016			