

Project Title :SRI. RAJENDRA PD. KEWAT

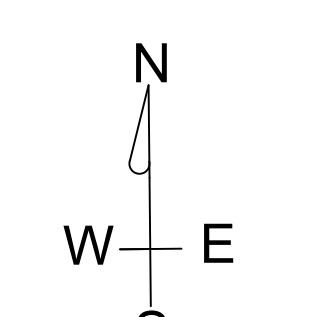
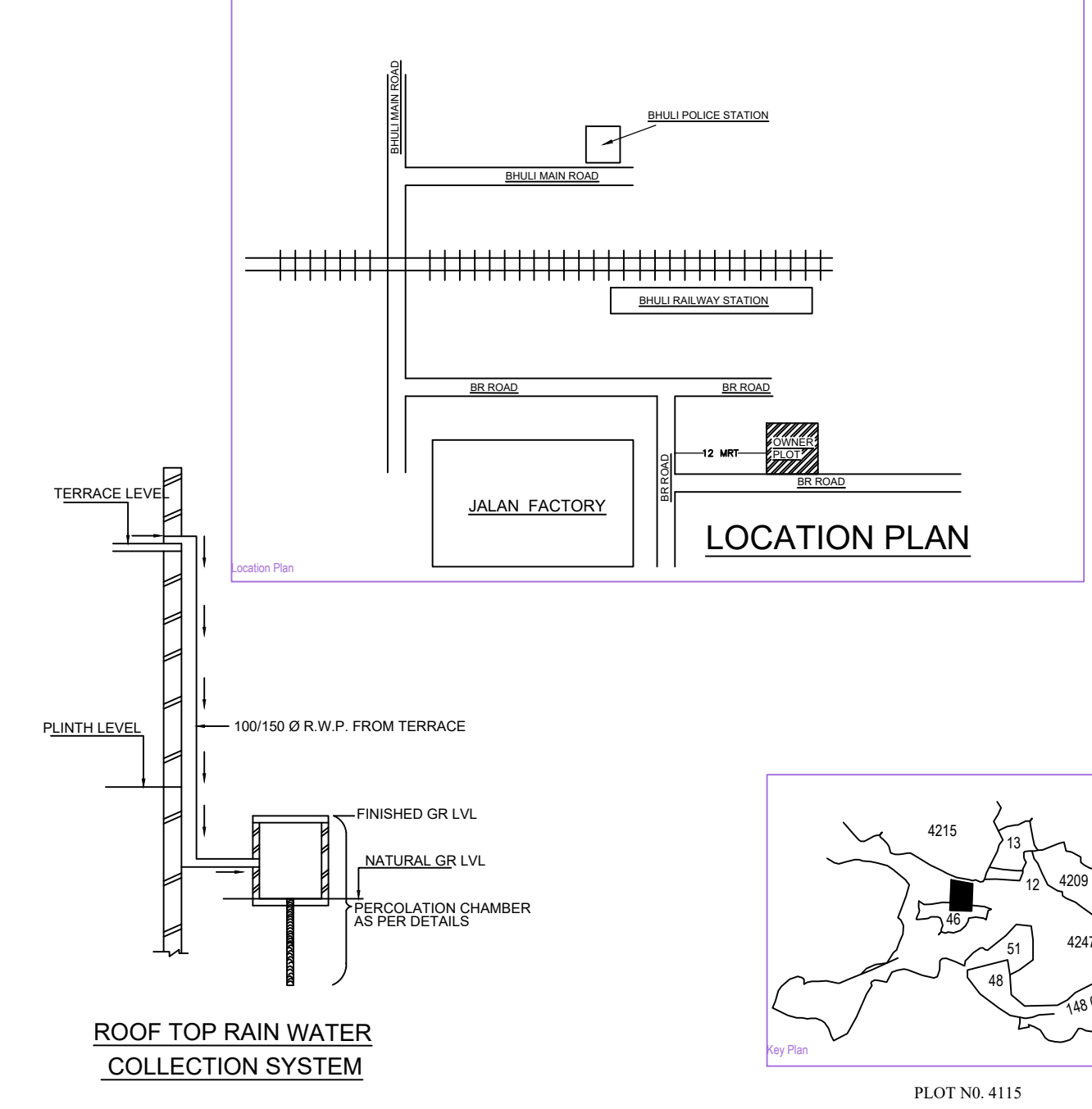
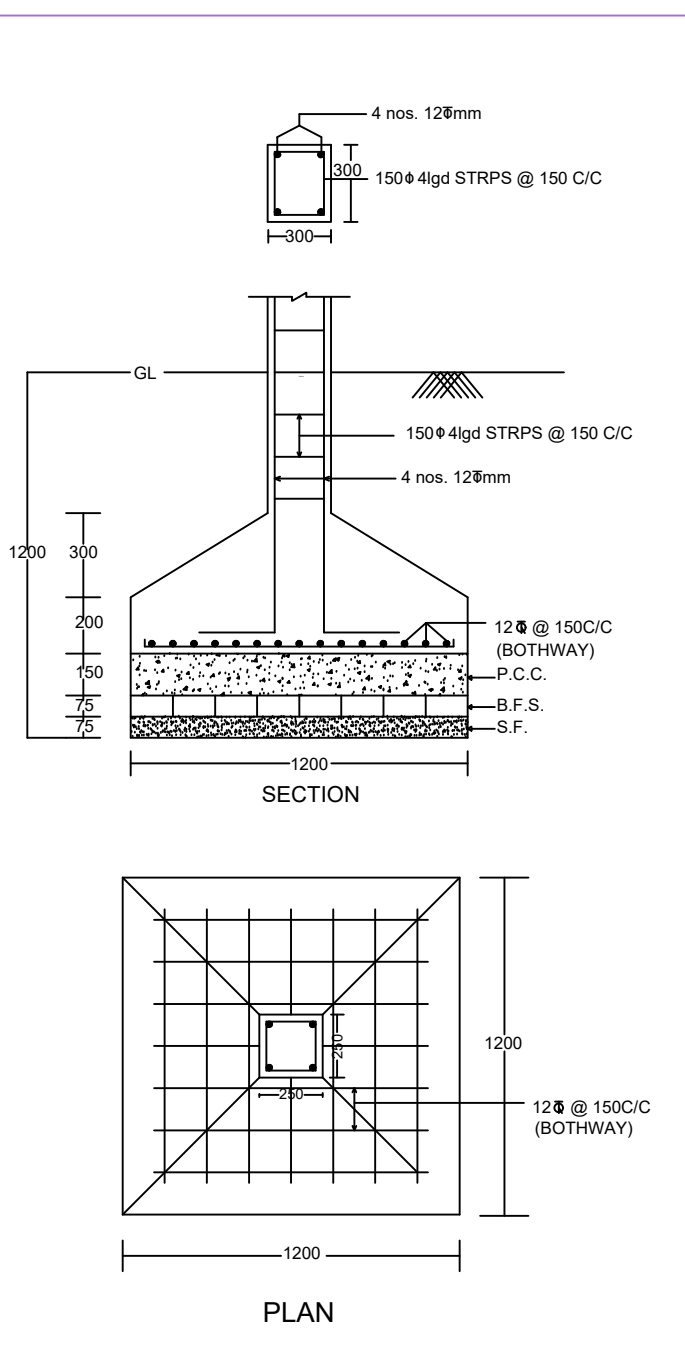
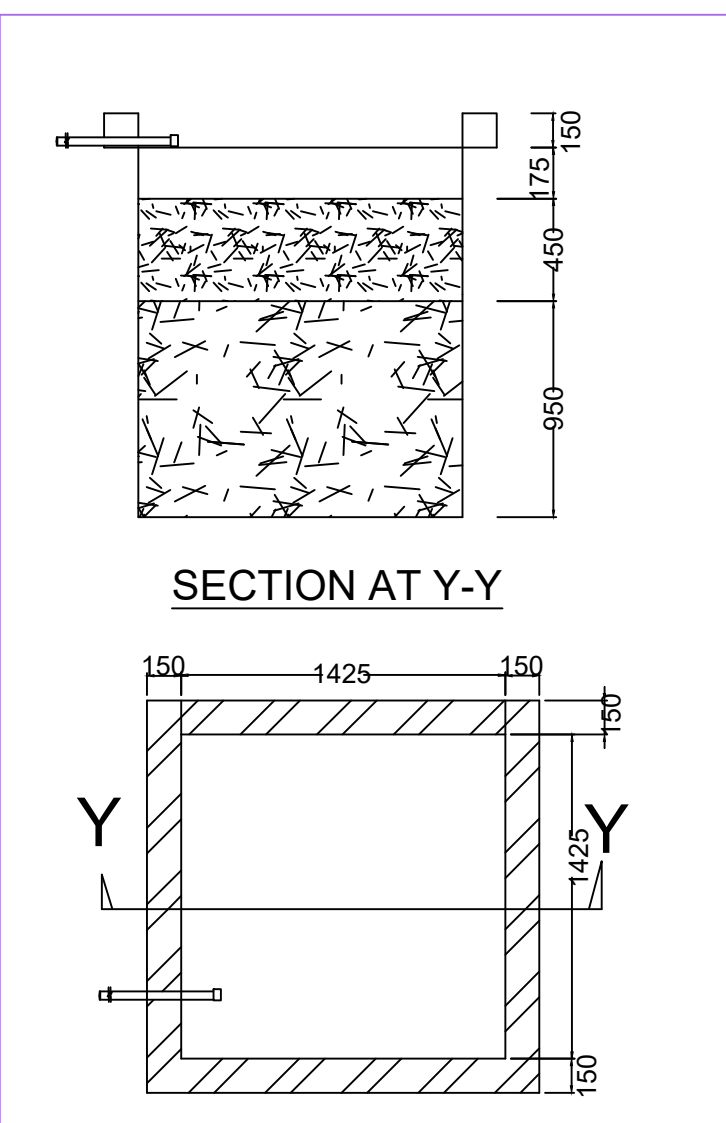
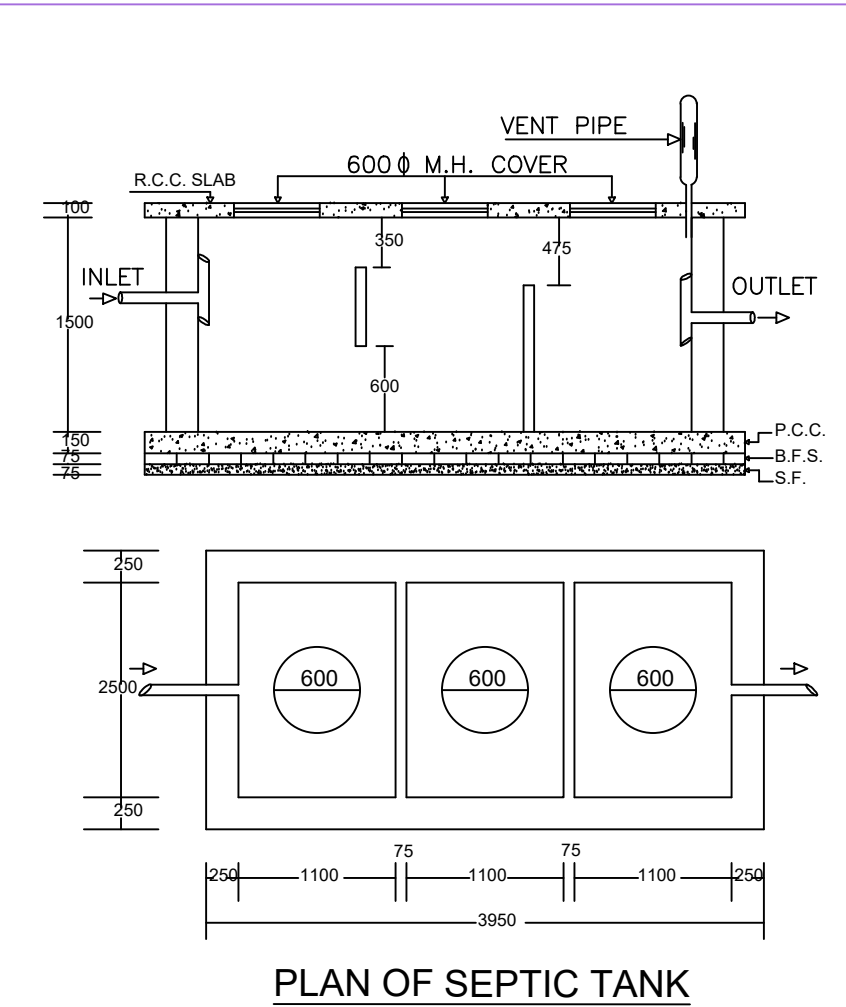
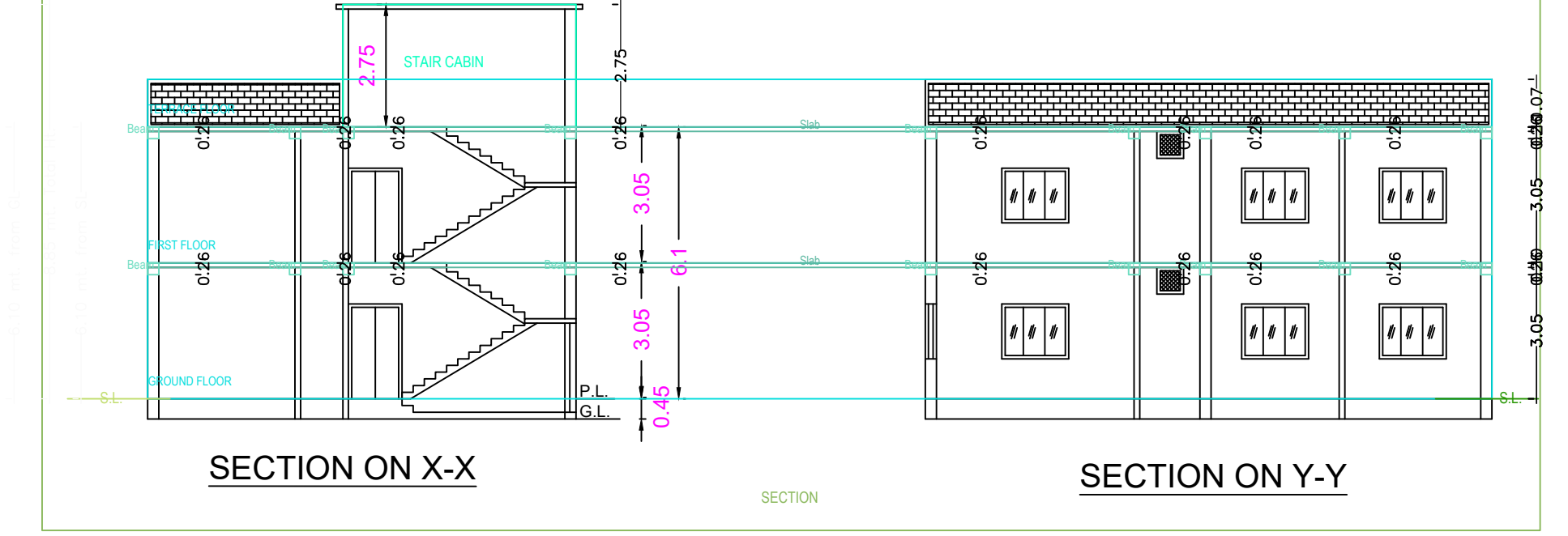
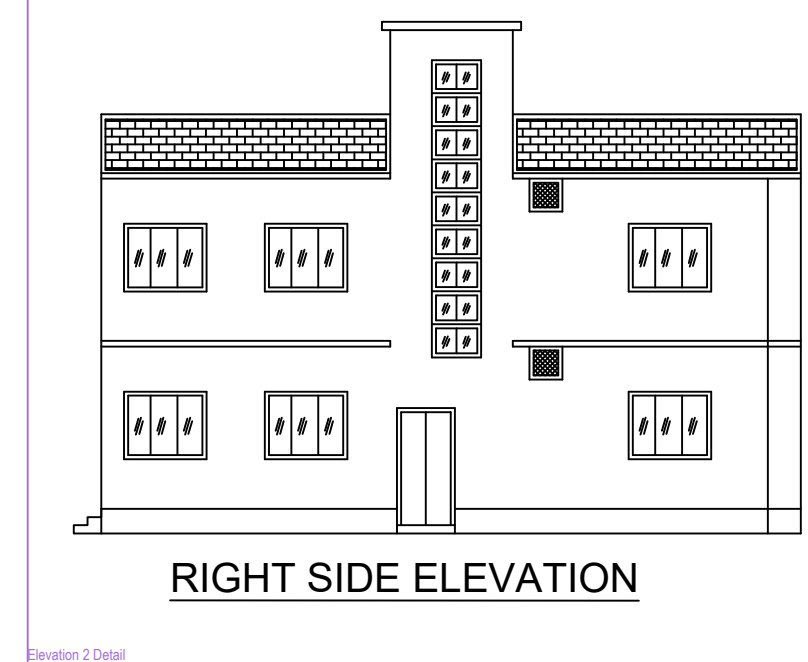
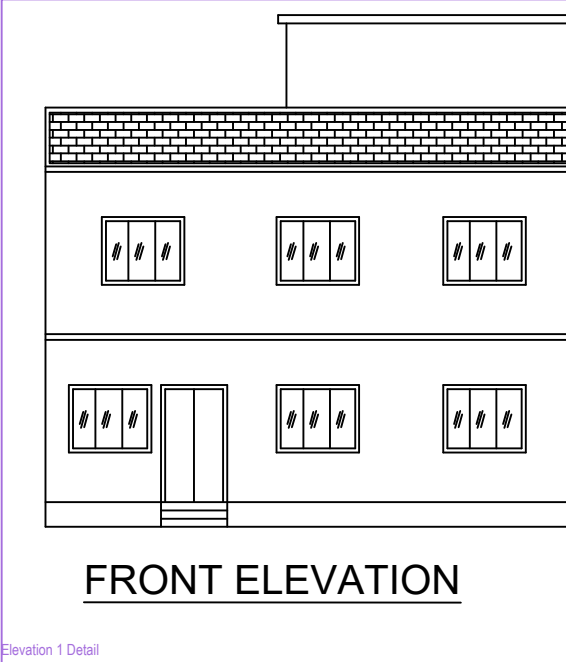

BRIEF SPACEFICATION
 FOUNDATION----- CEMENT CONCRETE (1:1.5:3)
 BRICK WORK IN FOUNDATION & SUPERSTRUCTURE
 FIRST CLASS BRICK WORK IN CEMENT MORTAR (1:6)
 D.P.C.-----25 D.P.C. IN CEMENT CONCRETE (1:2:4)
 FLOOR-----25 I.P.S. OVER 75 P.C.C.
 ROOF-----100 THK. R.C.C. ROOF (1:1.5:3)
 LINTEL-----150 THK. R.C.C. LINTEL (1:1.5:3)
 STAIRS-----RISE-- 150, TREAD-- 250

DETAILS OF AREA

TOTAL AREA (AS PER DEED)	200.66 SQM.
TOTAL AREA (AS PER SITE)	197.74 SQM.
GROUND FLOOR AREA	118.29 SQM.
FIRST FLOOR AREA	118.29 SQM.
TOTAL COVERED AREA	236.58 SQM.
% PLINTH AREA	59.82 %
FAR	1.19

SCHEDULE

D	=	1.200X2.100	W1	=	1.500X1.200
D1	=	1.050X2.100	V	=	0.600X0.600
D2	=	0.900X2.100			

TITLE OF DRAWING
 PLAN OF PROPOSED RESIDENTIAL BUILDING OF SRI. RAJENDRA PD. KEWAT S/O LATE. CHANDRADIP PD. KEWAT OF MATKURIA, R.L.Y. COLONY KUSUNDA, P.S. - KENDUADIH, DHANBAD, UNDER MOUZA -BHULI, NO.- 01, KHATA NO.- 113, OLD PLOT NO.- 4246 , 4247 IN THE DISTT. OF DHANBAD (JHARKHAND).

SIGNATURE OF OWNER

SIGNATURE OF ENGINEER

SCALE ALL DIMENSION ARE IN METRE

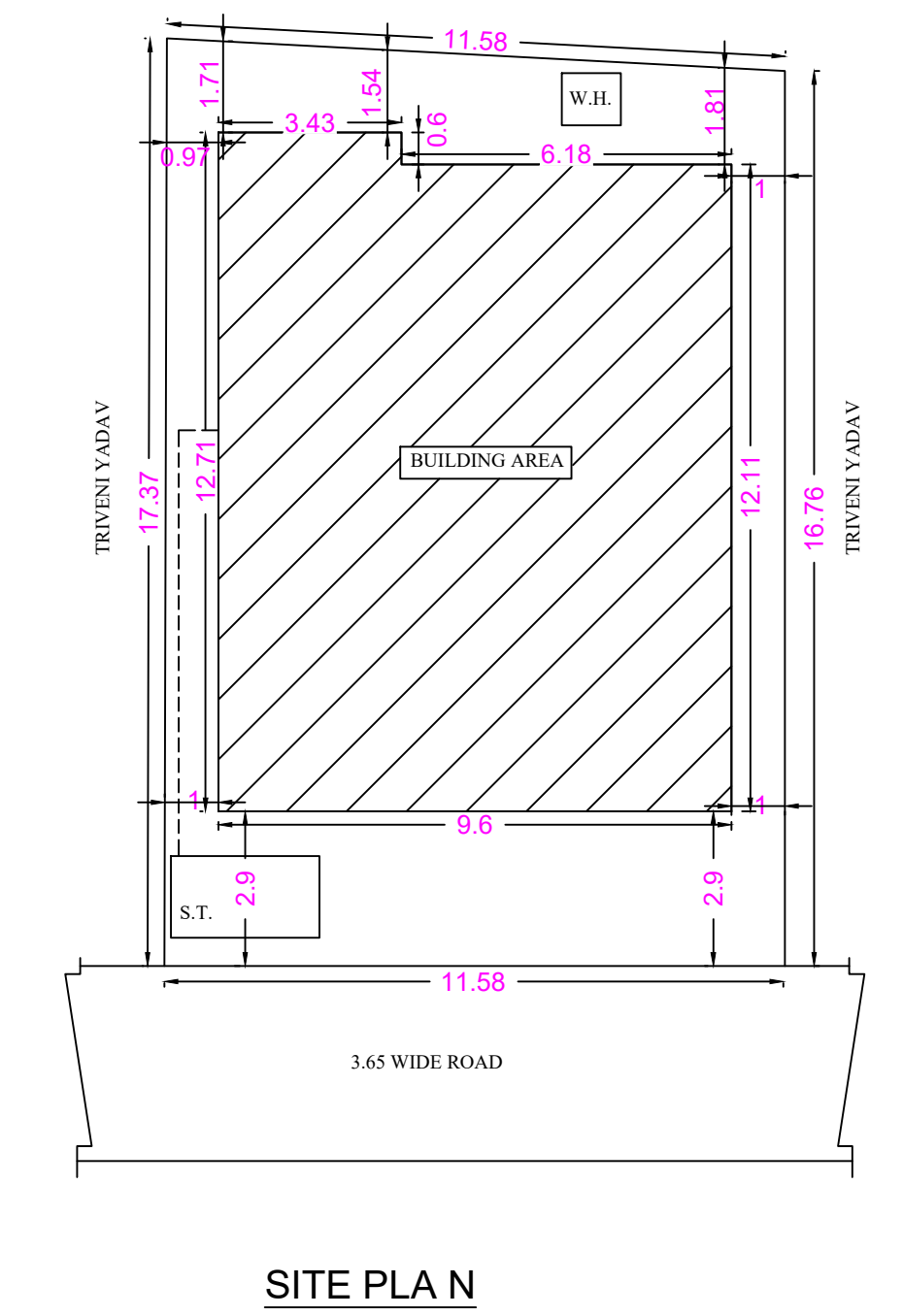
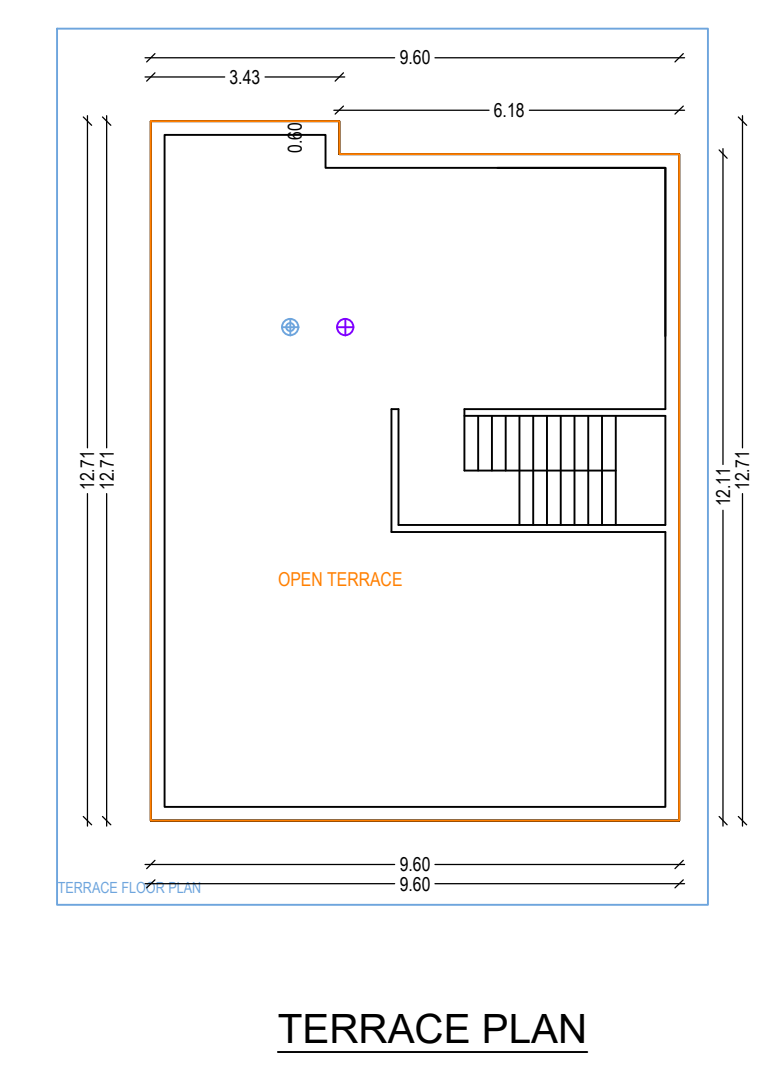
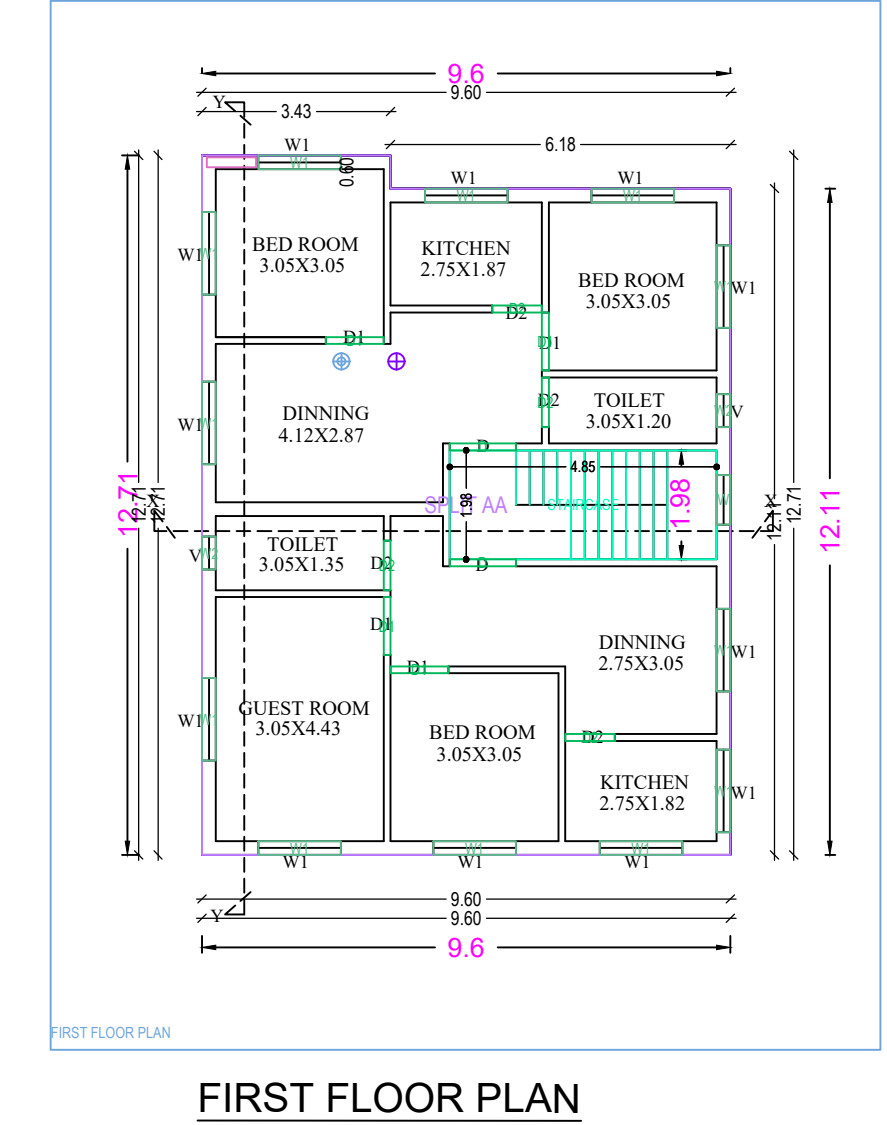
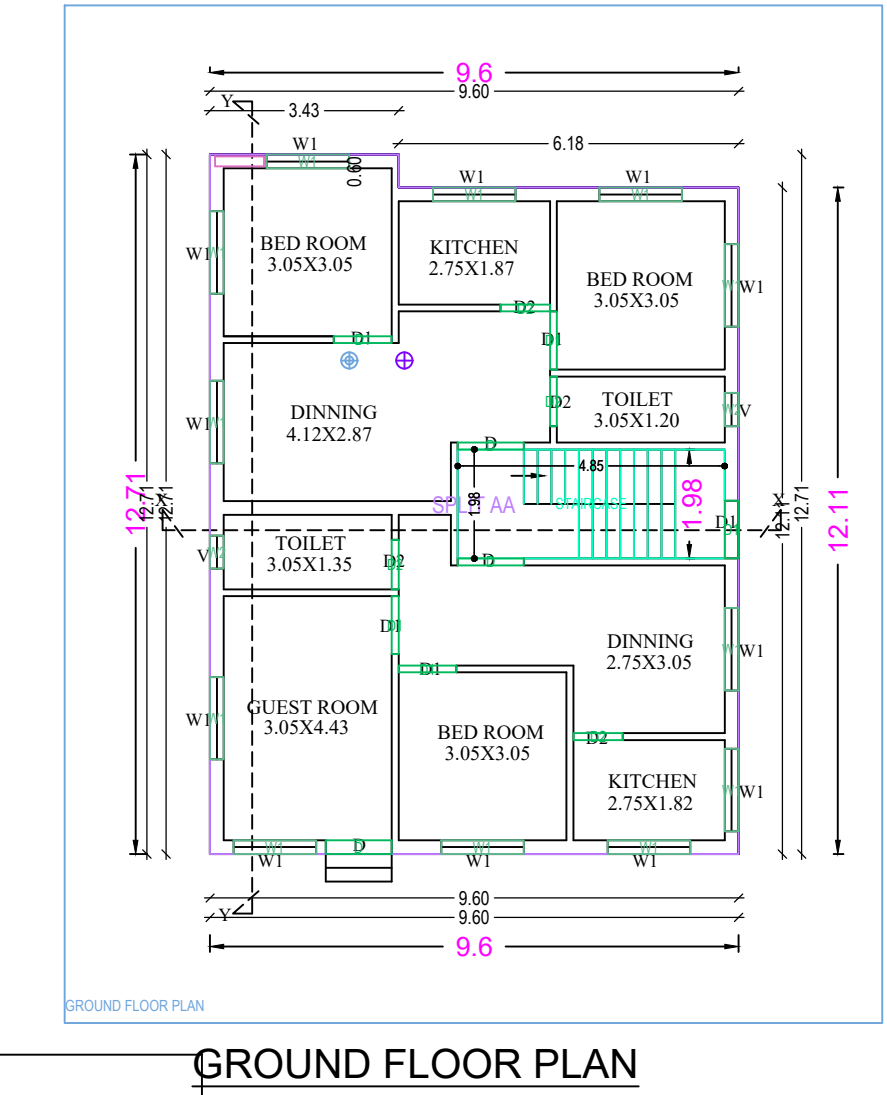
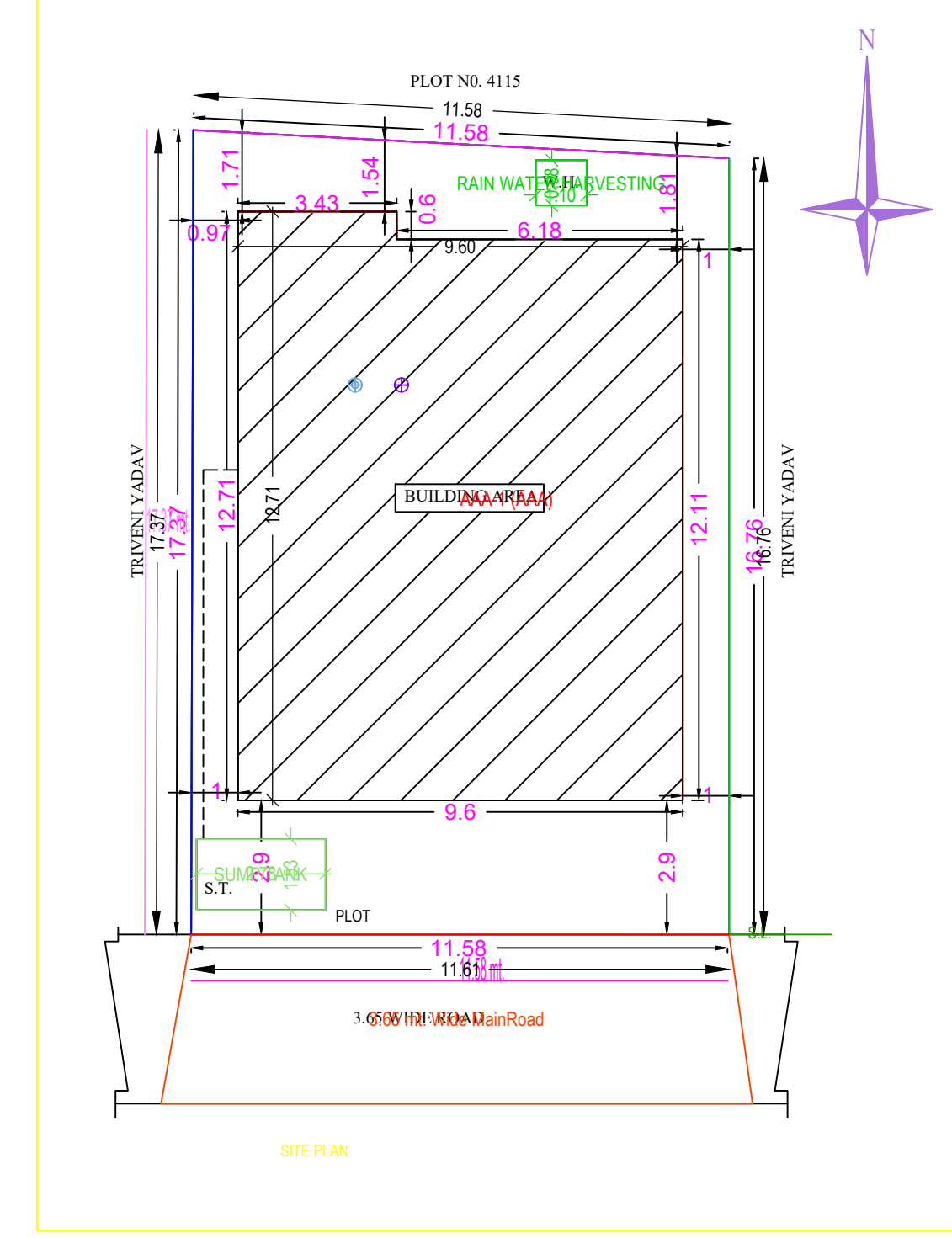

Building: AAA (AAA)

Floor Name	Total Built Up Area (Sq.m)	Proposed FAR Area (Sq.m)	Total FAR Area (Sq.m)	Terrace (No.)
Ground Floor	118.29	118.29	118.29	01
First Floor	118.29	118.29	118.29	01
Terrace Floor	0.00	0.00	0.00	00
Total	236.58	236.58	236.58	02

SCHEDULE OF JOINERY:

BUILDING NAME	NAME	LENGTH	HEIGHT	NO.S
AAA (AAA)	CS	0.90	2.10	08
	CI	1.50	2.10	02
	CI	1.58	2.10	02
	CI	1.50	2.10	02
Total				25

SCHEDULE OF JOINERY:

BUILDING NAME	NAME	LENGTH	HEIGHT	NO.S
AAA (AAA)	WI	1.50	1.20	08
	WI	0.90	1.20	01
	WI	1.50	1.20	24
	WI	1.50	1.20	24
Total				57

UNIBUA Table for Building: AAA (AAA)

FLOOR	Name	UNIBUA Type	UNIBUA Area (Sq.m)	Carpet Area (Sq.m)	No. of Rooms	No. of Terrace
GROUND FLOOR	SPLIT AA	FLAT	236.58	236.26	10	1
		Plot	236.58	236.26	25	1

AREA STATEMENT: DHANBAD MUNICIPAL CORPORATION

VERSION NO.	VERSION DATE
1.0.22	01/01/2019

PROJECT DETAIL

Project No.	Plot No.	Residential
Region - JHARKHAND URBAN LOCAL BODIES	Plot Section	Municipal Dwelling / Non Apartment
Project: DHANBAD	Land Use Zone	UR
Application Type - General Proposal	Abutting Road Width	
Project Type: Building Permissance	Plot No.	
Nature of Development - New	Revenue Survey No./Survey No. -	
Location - Old Area	Topic No.	
Site Location - NA	Holding No. -	
Map/Block Name -	Khata No. -	
Ward No.	Block -	
Road/Street -	East -	
	West -	

AREA DETAILS

AREA OF PLOT (Minimum)	(Sq. M)	50% MT
Net Plot Area (Covered Plot Area)	197.75	
Deduction from Gross Plot Area (A-Deductions)	197.75	
Balance Plot Area (Net Plot Area - Recreational/Amenity space)	197.75	
Plot Area for Coverage (Net Plot Area)	197.75	
Plot Area for First Floor Plot Area - (House/Working Area)	197.75	
Plot Area for First Floor Plot Area - (A-Deductions)	197.75	

COVERED CHECK

Proposed Coverage Area (50.82%)	118.29
Total Coverage Area (50.82%)	118.29

FACE CHECK

Proposed Area of FAR	236.58
Total Area of FAR	236.58

BUILT UP AREA CHECK

Total Proposed Built Up Area	236.58
ABOVE HEIGHT EXCEEDING (Plots)	0.00

COLOR INDEX

Color Index	Color
Color Index	Color
Color Index	Color
Color Index	Color

MARGIN DETAIL:

Building / Wing	Road Name	Front Margin	Rear Margin	Side1 Margin	Side2 Margin
AAA (AAA)	110 mt. Width	2.90	1.53	0.97	1.00

FAR & Tenement Details (Table 4c-1)

Building	No. of Deme Bldg	Total Built Up Area (Sq.m)	Proposed FAR Area (Sq.m)	Total FAR Area (Sq.m)	Terrace (No.)
AAA (AAA)	1	236.58	236.58	236.58	01
Subst Total	1	236.58	236.58	236.58	01