

Proposal Basic Information

Proposal File No.	DMC/BP/0255/W21/2018
Owner Name	Vimala Devi
Khata No	90
Plot No	562
Village Name	Dhaiya
Use	Residential
SubUse	Bungalow/ Dwelling / Non Apartment

Building :A (BLDG)

Floor Name	Total Built Up Area (Sq.mt.)	Proposed FAR Area (Sq.mt.) Resi.	Total FAR Area (Sq.mt.)	Total Consumed Additional FAR Area (Sq.mt.)	Tnmt (No.)
Ground Floor	45.72	45.72	45.72	45.72	01
First Floor	45.72	45.72	45.72	45.72	00
Terrace Floor	0.00	0.00	0.00	0.00	00
Total :	91.44	91.44	91.44	91.44	01
Total Number of Same Buildings	1				
Total :	91.44	91.44	91.44	91.44	01

Building USE/SUBUSE Details

Building Name	Building Use	Building SubUse	Building Structure
A (BLDG)	Residential	Bungalow/ Dwelling / Non Apartment	Non-Highrise

UnitBUA Table for Building :A (BLDG)

FLOOR	Name	UnitBUA Type	UnitBUA Area	Carpet Area	No. of Rooms	No. of Tenement
GROUND FLOOR PLAN	SPLIT RESI.	FLAT	91.43	91.38	4	1
FIRST FLOOR PLAN	SPLIT RESI.	FLAT	0.00	0.00	4	0
Total:	-	-	91.43	91.38	8	1

COLOR INDEX	
PLOT BOUNDARY	Black
ABUTTING ROAD	Green
PROPOSED CONSTRUCTION	Red
COMMON PLOT	Yellow
ROAD WIDENING AREA	Blue
EXISTING (To be retained)	Light Blue
EXISTING (To be demolished)	White

FAR & Tenement Details (Table 4c-1)

Building	No. of Same Bldg	Total Built Up Area (Sq.mt.)	Proposed FAR Area (Sq.mt.) Resi.	Total FAR Area (Sq.mt.)	Total Consumed Additional FAR Area (Sq.mt.)	Tnmt (No.)
A (BLDG)	1	91.44	91.44	91.44	91.44	01
Grand Total :	1	91.44	91.44	91.44	91.44	01

AREA STATEMENT	VERSION NO.: 1.0.50
DHANBAD MUNICIPAL CORPORATION	VERSION DATE: 16/10/2020

PROJECT DETAIL:	
Region: JHARKHAND URBAN LOCAL BODIES	Plot Use: Residential
District: DHANBAD	Plot SubUse: Bungalow/ Dwelling / Non Apartment
Authority: DHANBAD MUNICIPAL CORPORATION	Plot/Neighbourhood/Structure: NA
Inward No: DMC/BP/0255/W21/2018	Plot/SubPlot No: 562
Application Type: General Proposal	North: CTS No. - same plot
Project Type: Building Permission	South: CTS No. - same plot
Nature of Development: New	East: Road Width - 3.66
Location of Development Area: Old Area	West: CTS No. - plot no 560

AREA DETAILS:		SQ.MT.
AREA OF PLOT (Minimum)	(A)	94.93
Deduction for NetPlot Area		
Surrender Free of Cost		10.90
Total		10.90
NET AREA OF PLOT(Gross Plot Area - Deduction from Gross Plot area)	(A-Deductions)	84.04
Deduction for Balance Plot Area(from Gross Plot Area)		
Surrender Free of Cost		10.90
Common Plot		5.85
Total		16.75
BALANCE AREA OF PLOT(Net Plot Area - Recreational/Amenity space)	(A-Deductions)	78.19
PLOT AREA FOR COVERAGE(Net Plot Area)	(A-Deductions)	84.04
Plot Area for FAR (Net Plot Area + RoadWidening Area)	(A-Deductions)	94.93
COVERAGE CHECK		
Permissible Coverage area (70.00 %)		58.83
Proposed Coverage Area (54.40 %)		45.72
Total Prop. Coverage Area (54.4 %)		45.72
Balance coverage area (15.60 %)		13.11
FAR CHECK		
Perm. FAR Area (1.20)		113.92
Total Perm. FAR area		113.92
Residential FAR		91.43
Proposed FAR Area		91.43
Total Proposed FAR Area		91.43
Consumed FAR (Factor)		0.96
Balance FAR Area		22.49
BUILT UP AREA CHECK		
Total Proposed BuiltUp Area		91.44
ARCHITECT (Regd)		ASHOK KUMAR
ENGINEER (Regd)		
SUPERVISOR (Regd)		
OWNER (Regd)		Vimala Devi
DEVELOPMENT AUTHORITY		LOCAL BODY

Buildingwise Floor FAR Details

Floor Name	Building Name A (BLDG)		Total	
	Proposed Built Up Area (Sq.mt.)	Proposed FAR Area (Sq.mt.)	Total Proposed Built Up Area (Sq.mt.)	Total FAR Area (Sq.mt.)
Ground Floor	45.72	45.72	45.72	45.72
First Floor	45.72	45.72	45.72	45.72
Terrace Floor	0.00	0.00	0.00	0.00
Total :	91.44	91.44	91.44	91.44

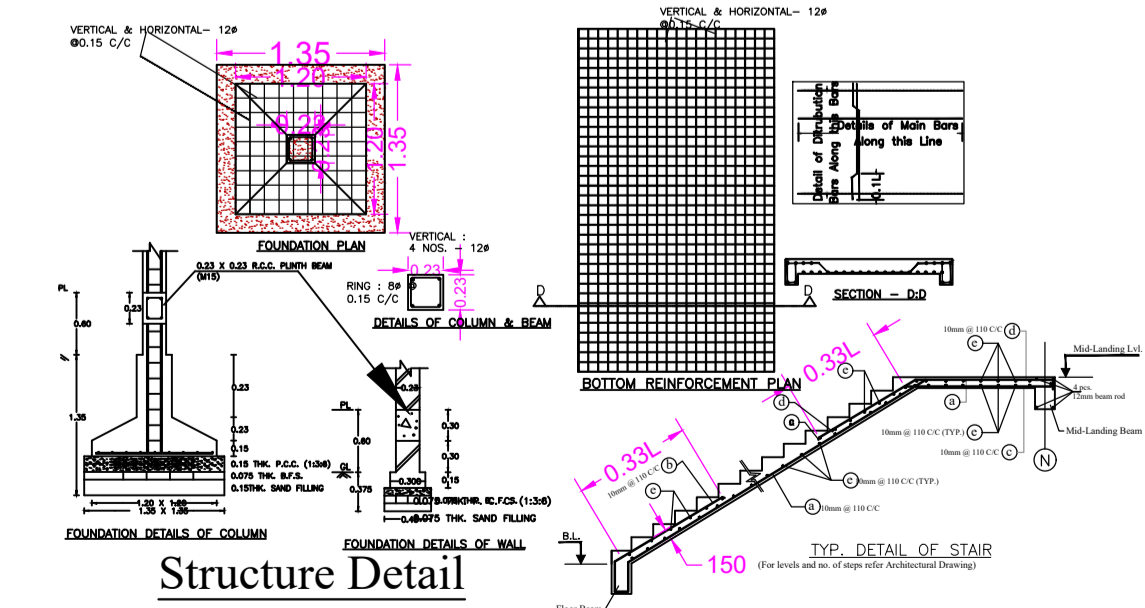
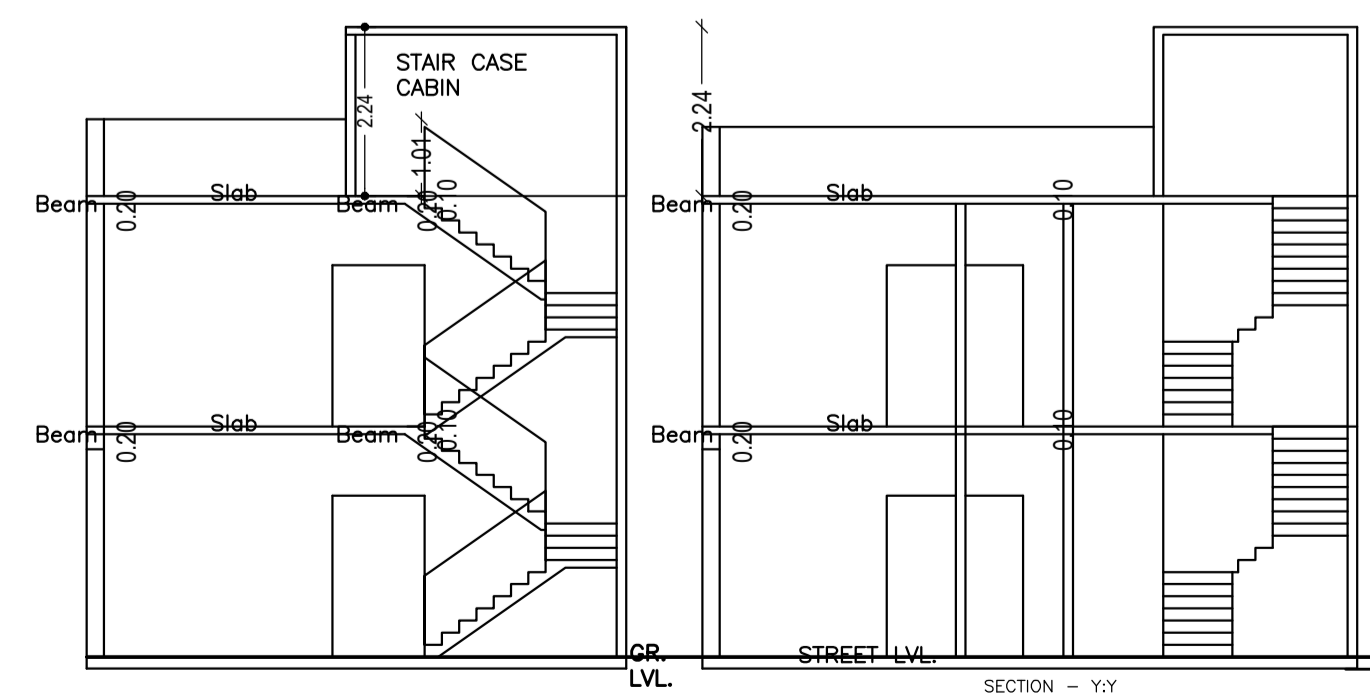
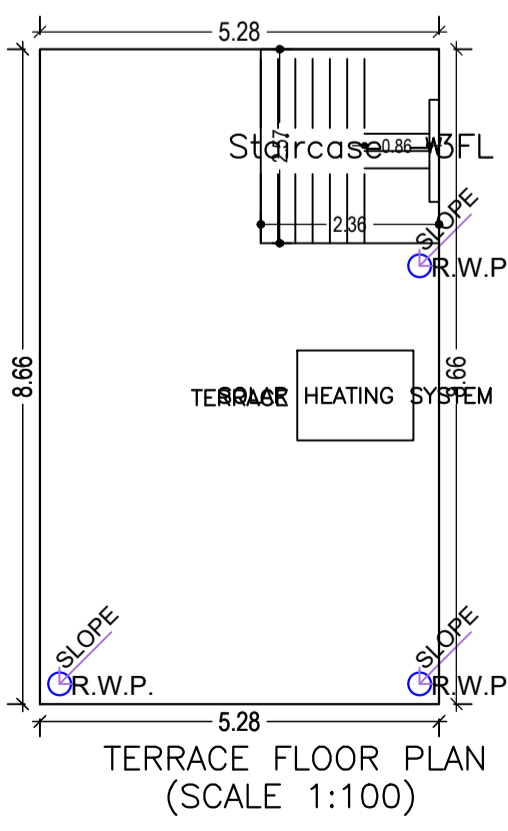
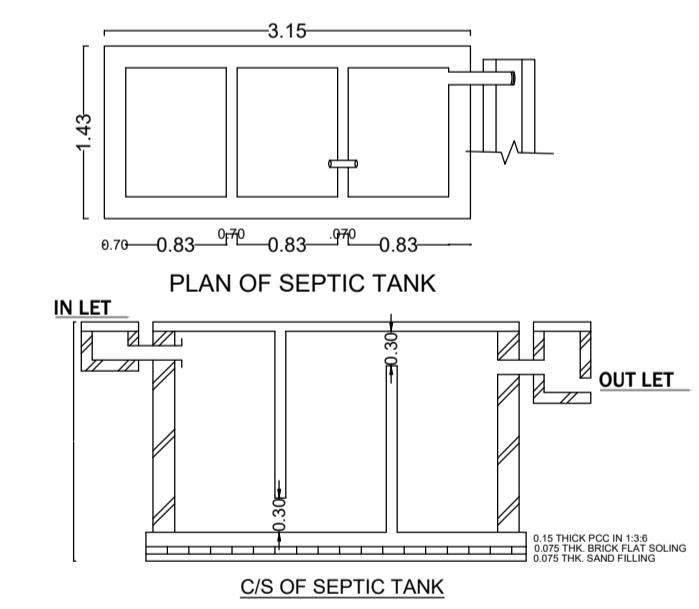
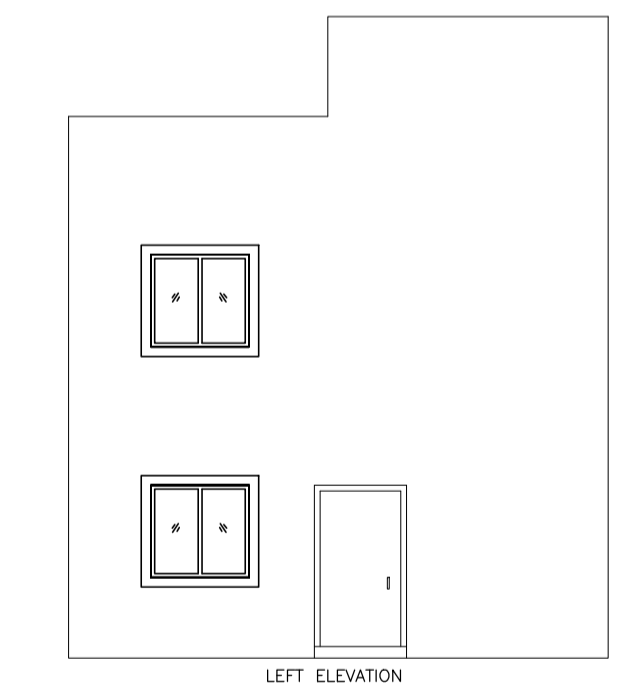
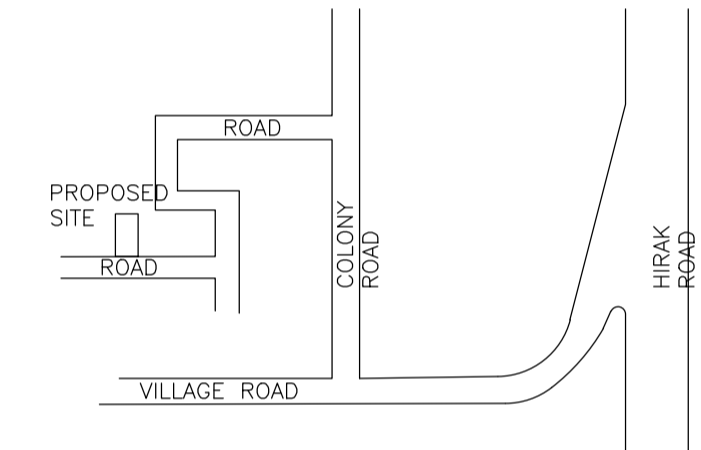
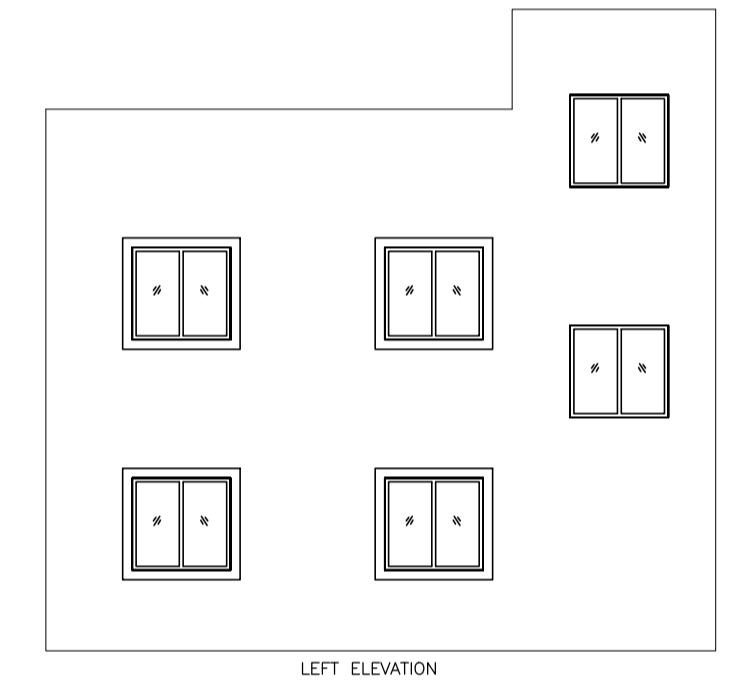
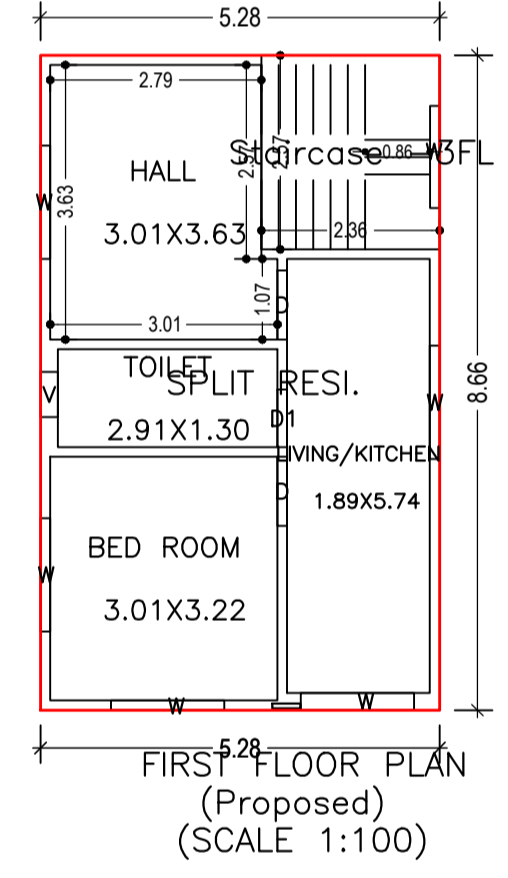
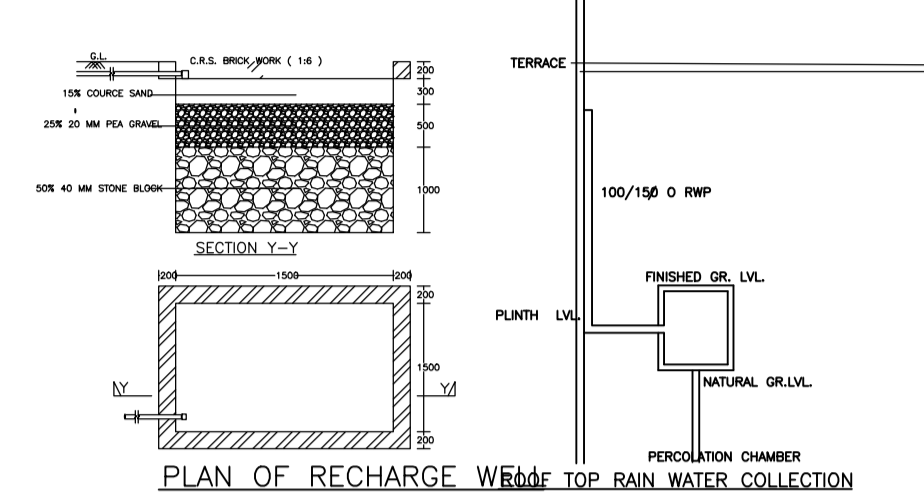
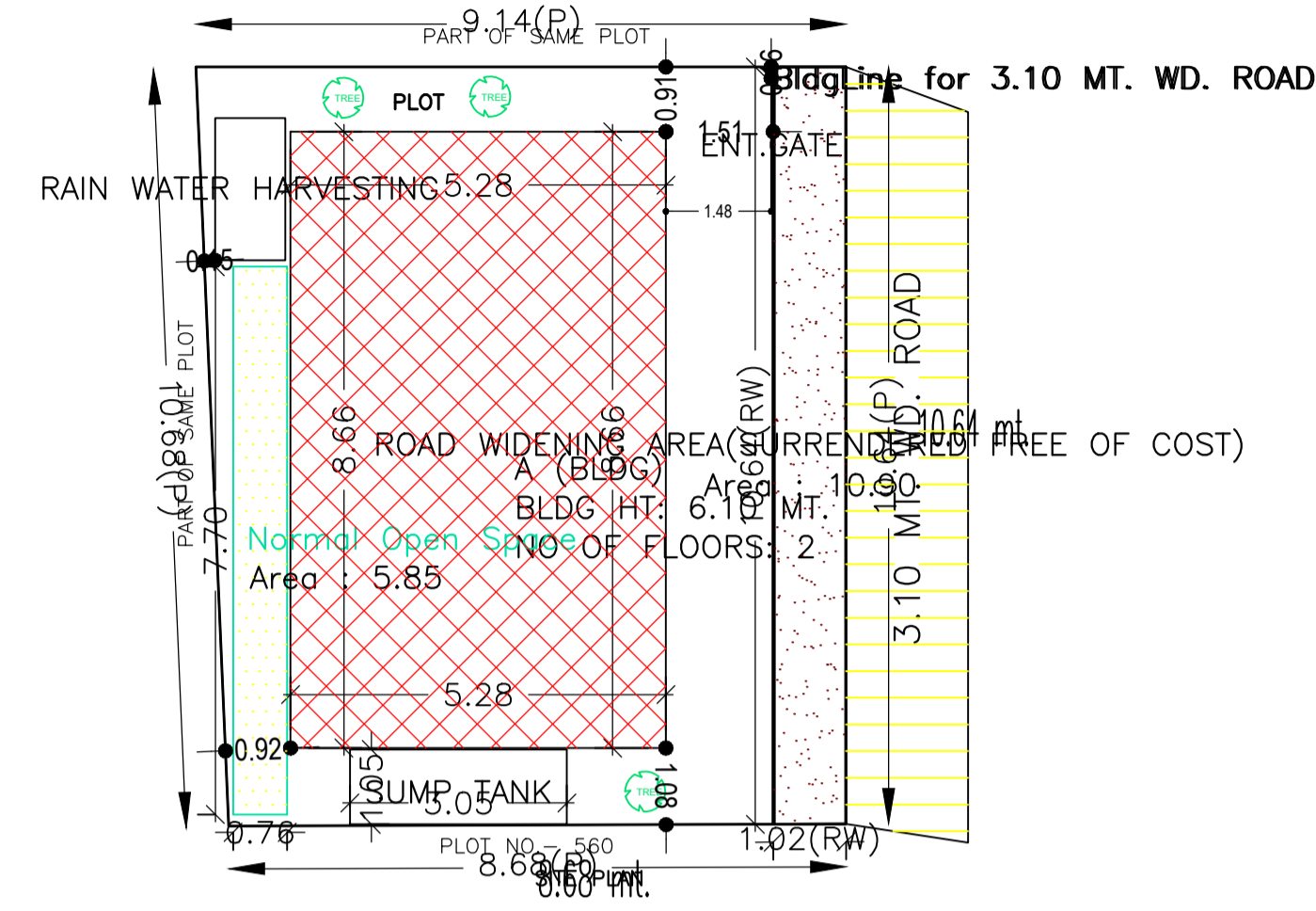
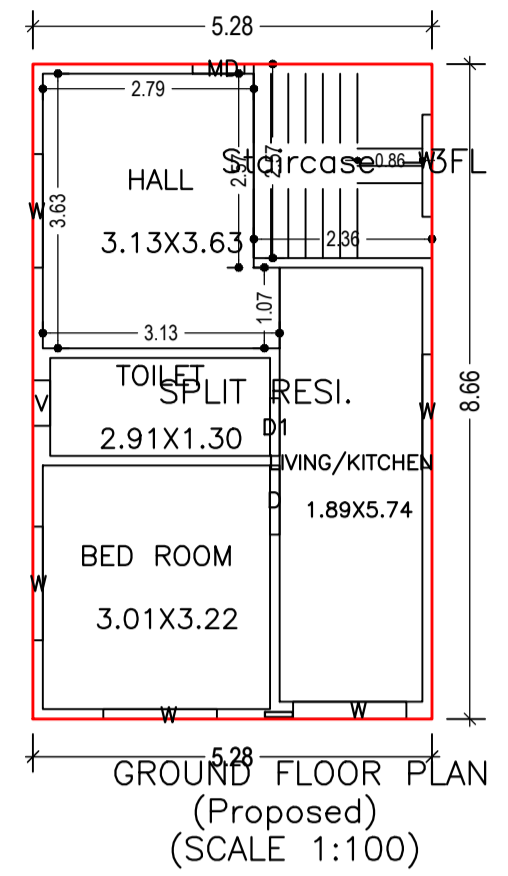

LTP NAME AND SIGNATURE	STRUCTURAL ENG'S NAME AND SIGNATURE	BUILDER NAME AND SIGNATURE	DIGITAL SIGNATURE
ASHOK KUMAR DMC/ENG/0011/2017			