

AREA STATEMENT DHANBAD MUNICIPAL CORPORATION	VERSION NO.: 1.0.25 VERSION DATE: 12/04/2018	SQ.MT.
PROJECT DETAIL: Region: BHARHURAND URBAN LOCAL BODIES District: DHANBAD Authority: DHANBAD MUNICIPAL CORPORATION Inward No: DMC/BP/0015/W23/2018 Application Type: General Proposal Project Type: Building Permission Nature of Development: New Location of Development Area: Old Area	Plot Use: Residential Plot SubUse: Bungalow/ Dwelling / Non Apartment PlotNearby/ReligiousStructure: NA Plot/SubPlot No: 2298 North: - South: - East: - West: -	
AREA DETAILS: AREA OF PLOT (Minimum)	(A)	92.90
NET AREA OF PLOT(Gross Plot Area - Deduction from Gross Plot area)	(A-Deductions)	92.90
Deduction for Balance Plot Area(from Gross Plot Area)		
Common Plot		10.65
Total		10.65
BALANCE AREA OF PLOT(Net Plot Area - Recreational/Amenity space)	(A-Deductions)	82.25
PLOT AREA FOR COVERAGE(Net Plot Area)	(A-Deductions)	92.90
Plot Area for FAR (Net Plot Area + Road/Widening Area)	(A-Deductions)	92.90
COVERAGE CHECK		
Permissible Coverage area (70.00 %)		65.03
Proposed Coverage Area (62.52 %)		58.08
Total Prop. Coverage Area (62.52 %)		58.08
Balance coverage area (7.48 %)		6.95
FAR CHECK		
Perm. FAR Area (1.50)		139.35
Total Perm. FAR area		139.35
Residential FAR		116.16
Proposed FAR Area		116.16
Total Proposed FAR Area		116.16
Consumed FAR (Factor)		1.25
Balance FAR Area		23.19
BUILT UP AREA CHECK		
Total Proposed BuiltUp Area		116.16
ARCHITECT (Regd)	PARTHA - PAL	
ENGINEER (Regd)		
SUPERVISOR (Regd)		
OWNER (Regd)	SMT SONALI SINGH AND VIKRAM KUMAR	
DEVELOPMENT AUTHORITY	LOCAL BODY	

COLOR INDEX	
PLOT BOUNDARY	Black
ABUTTING ROAD	Green
PROPOSED CONSTRUCTION	Red
COMMON PLOT	Yellow
ROAD WIDENING AREA	Blue
EXISTING (To be retained)	Light Blue
EXISTING (To be demolished)	Orange

Buildingwise Floor FAR Details				
Floor Name	Building Name		Total	
	Proposed Built Up Area (Sq.mt.)	Proposed FAR Area (Sq.mt.)	Total Proposed Built Up Area (Sq.mt.)	Total FAR Area (Sq.mt.)
Ground Floor	58.08	58.08	58.08	58.08
First Floor	58.08	58.08	58.08	58.08
Terrace Floor	0.00	0.00	0.00	0.00
Total :	116.16	116.16	116.16	116.16

Building USE/SUBUSE Details			
Building Name	Building Use	Building SubUse	Building Structure
A (RESI 1)	Residential	Residential Bldg/Apartment	Non-Highrise

FAR & Tenement Details (Table 4c-1)						
Building	No. of Same Bldg	Total Built Up Area (Sq.mt.)	Proposed FAR Area (Sq.mt.)	Total FAR Area (Sq.mt.)	Total Consumed Additional FAR Area (Sq.mt.)	Tnmt (No.)
A (RESI 1)	1	116.16	116.16	116.16	116.16	01
Grand Total :	1	116.16	116.16	116.16	116.16	01

Building :A (RESI 1)					
Floor Name	Total Built Up Area (Sq.mt.)	Proposed FAR Area (Sq.mt.)	Total FAR Area (Sq.mt.)	Total Consumed Additional FAR Area (Sq.mt.)	Tnmt (No.)
Ground Floor	58.08	58.08	58.08	58.08	01
First Floor	58.08	58.08	58.08	58.08	00
Terrace Floor	0.00	0.00	0.00	0.00	00
Total :	116.16	116.16	116.16	116.16	01
Total Number of Same Buildings :	1				
Total :	116.16	116.16	116.16	116.16	01

SCHEDULE OF DOOR:

BUILDING NAME	NAME	LENGTH	HEIGHT	NOS
A (RESI 1)	D2	0.76	2.10	02
A (RESI 1)	D1	0.91	2.10	02
A (RESI 1)	D	1.07	2.10	06

SCHEDULE OF WINDOW/VENTILATION:

BUILDING NAME	NAME	LENGTH	HEIGHT	NOS
A (RESI 1)	V	0.61	1.20	02
A (RESI 1)	W2	0.91	1.20	02
A (RESI 1)	W1	1.22	1.20	06
A (RESI 1)	W	1.52	1.20	02

UnitBUA Table for Building :A (RESI 1)

FLOOR	Name	UnitBUA Type	UnitBUA Area	Carpet Area	No. of Rooms	No. of Tenement
GROUND FLOOR PLAN	SPLIT RESI 1	FLAT	82.30	81.80	5	1
FIRST FLOOR PLAN	SPLIT RESI 1	FLAT	0.00	0.00	6	0
Total:	-	-	82.30	81.80	11	1

LTP NAME AND SIGNATURE	STRUCTURAL ENG'S NAME AND SIGNATURE	BUILDER NAME AND SIGNATURE
PARTHA - PAL DMC/ENG/0021/2016		

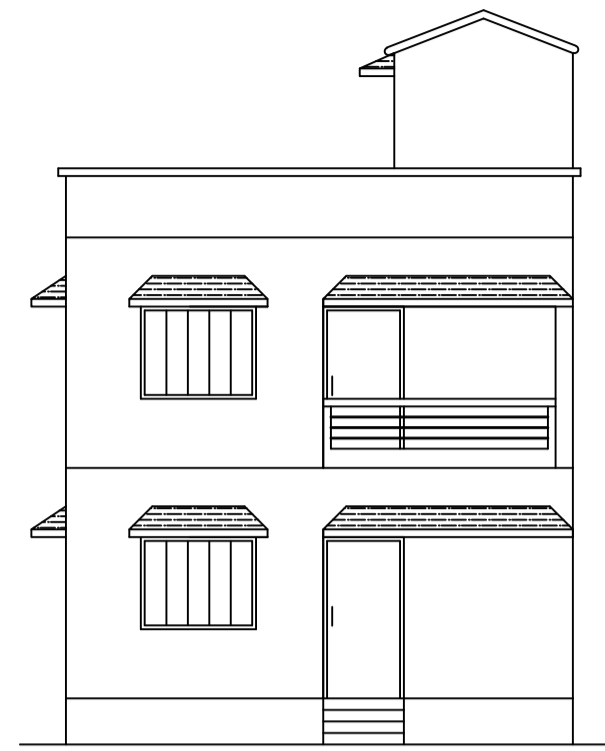
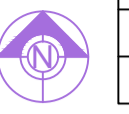

FRONT ELEVATION

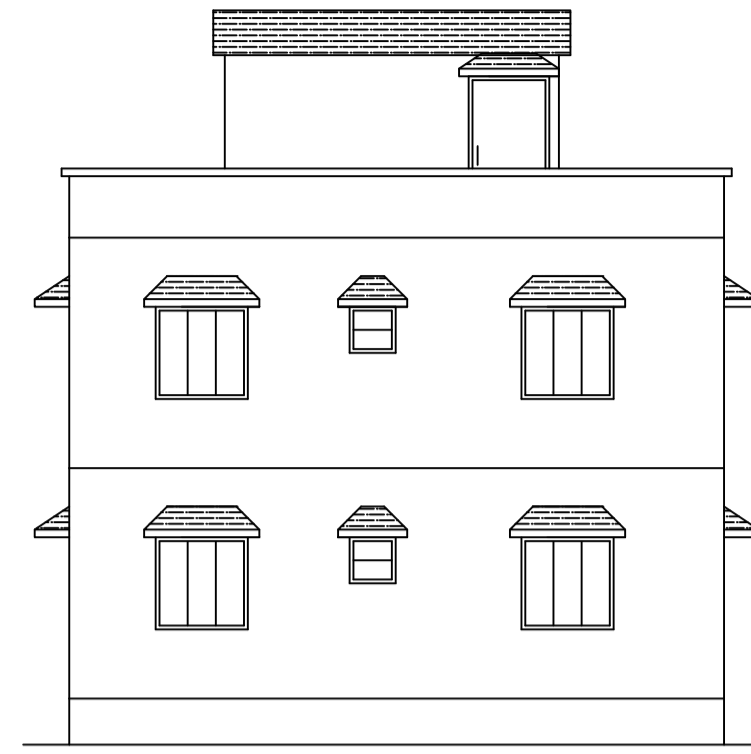

LEFT SIDE ELEVATION

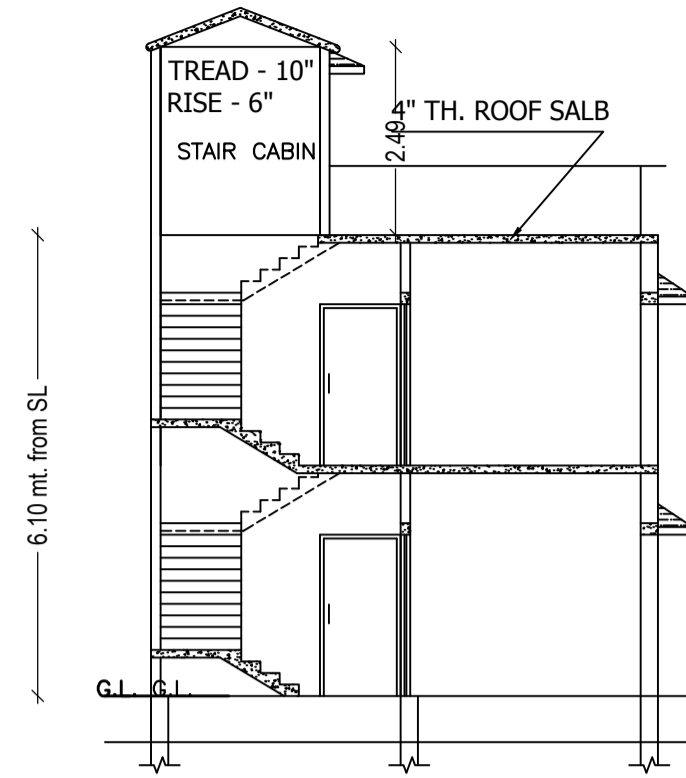

SECTION A - B

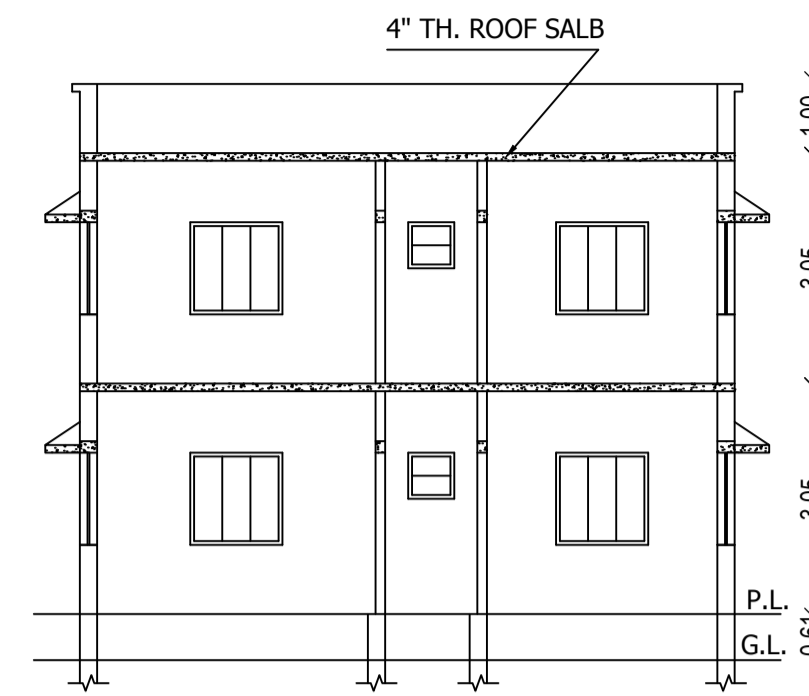

SECTION X - Y

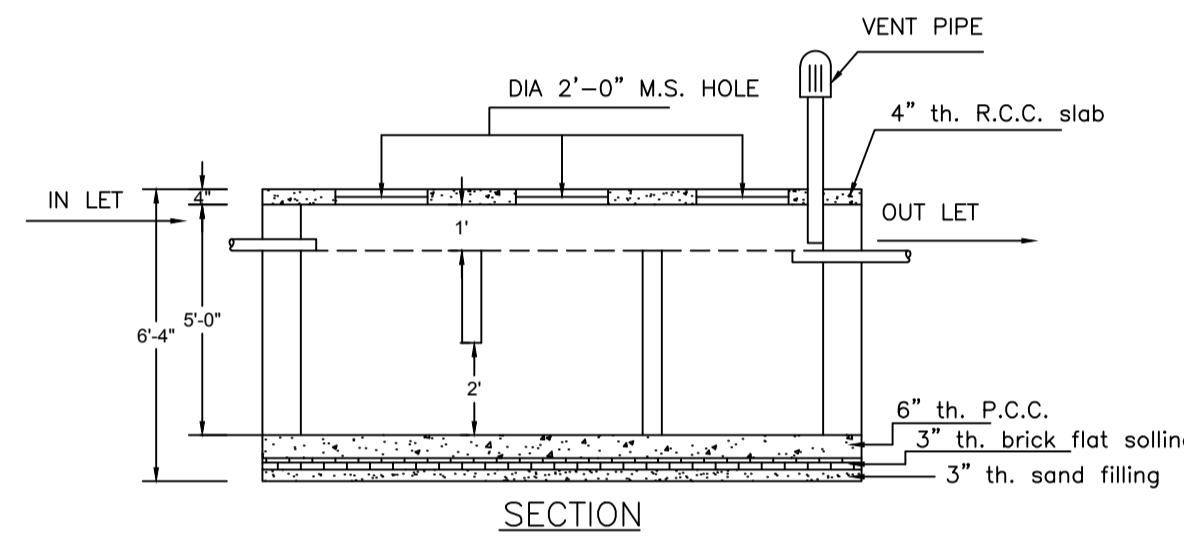

SECTION

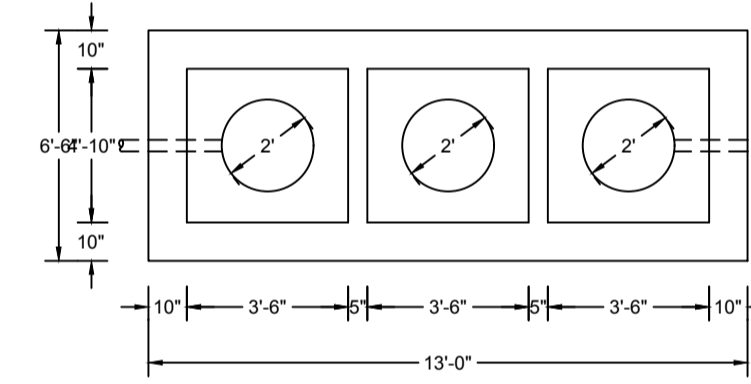

DETAILS OF SEPTIC TANK
SCALE - 1" = 4'-0"

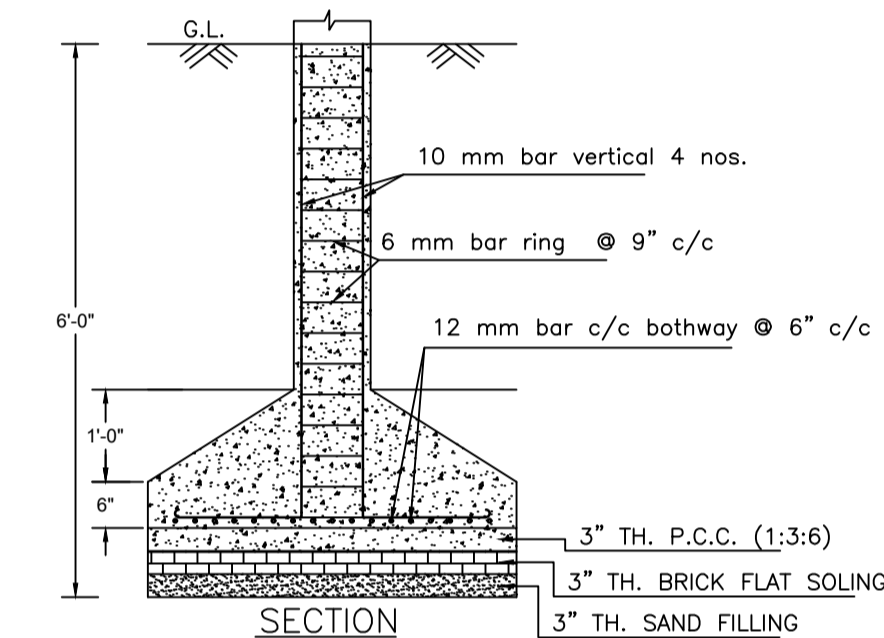

SECTION

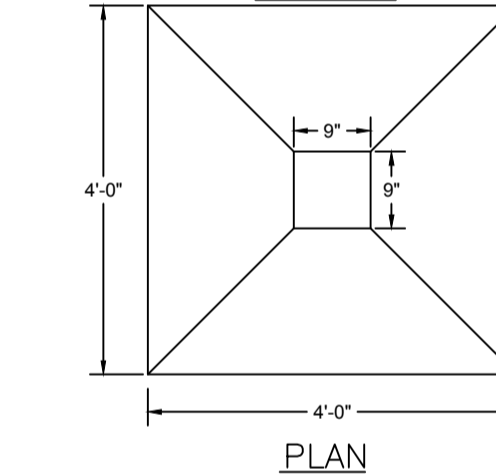

DETAILS OF COLUMN FOUNDATION
SCALE - 1" = 2'-0"

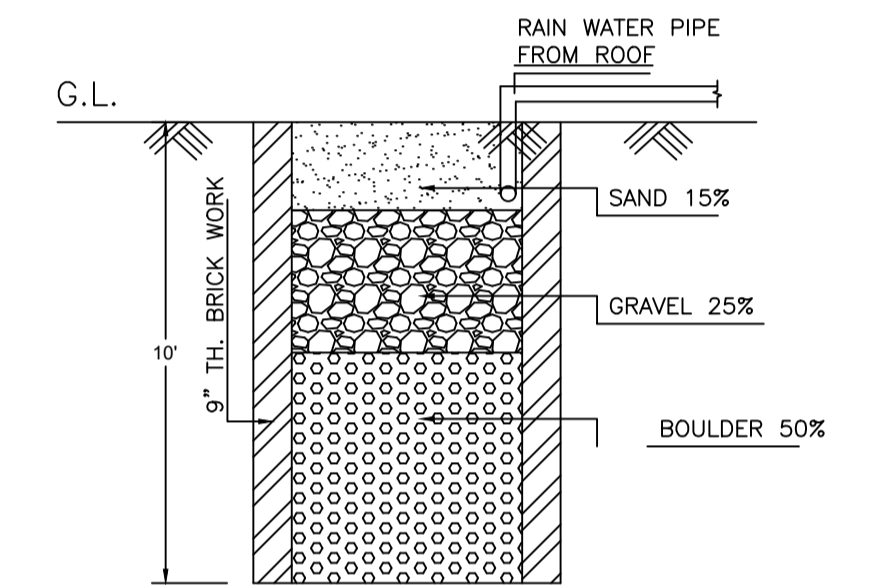

SECTION

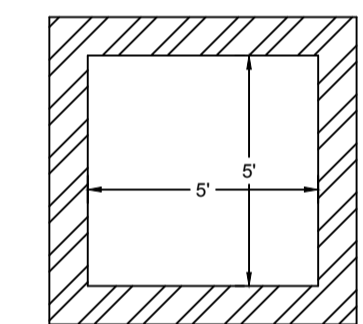

DETAILS DRAWING OF RAIN
WATER HARVESTING
SCALE - 1" = 2'-0"

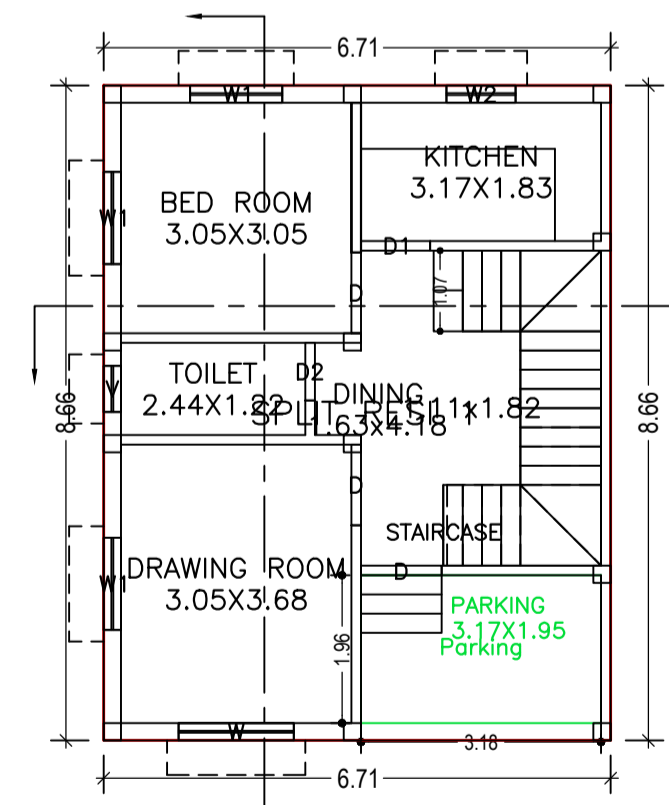

GROUND FLOOR PLAN
(Proposed)
(SCALE 1:100)

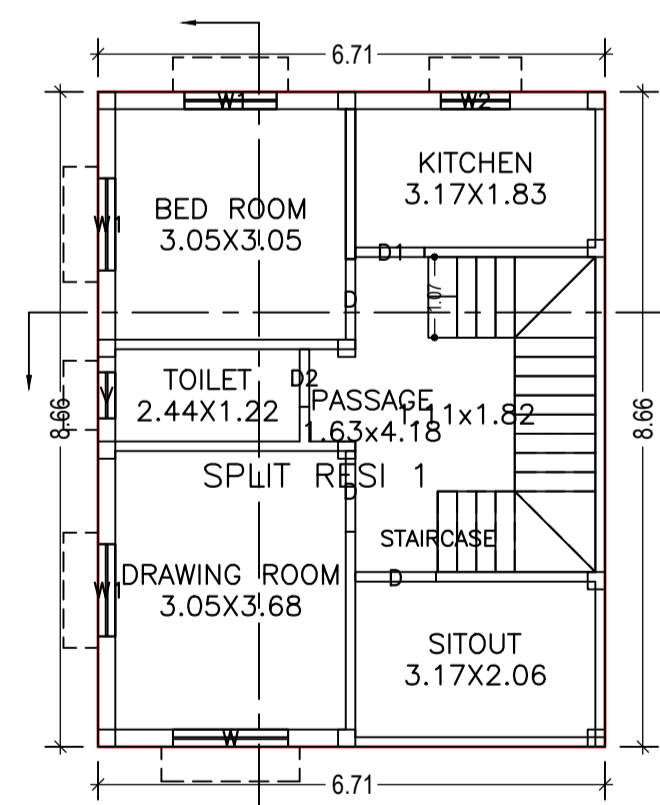

FIRST FLOOR PLAN
(Proposed)
(SCALE 1:100)

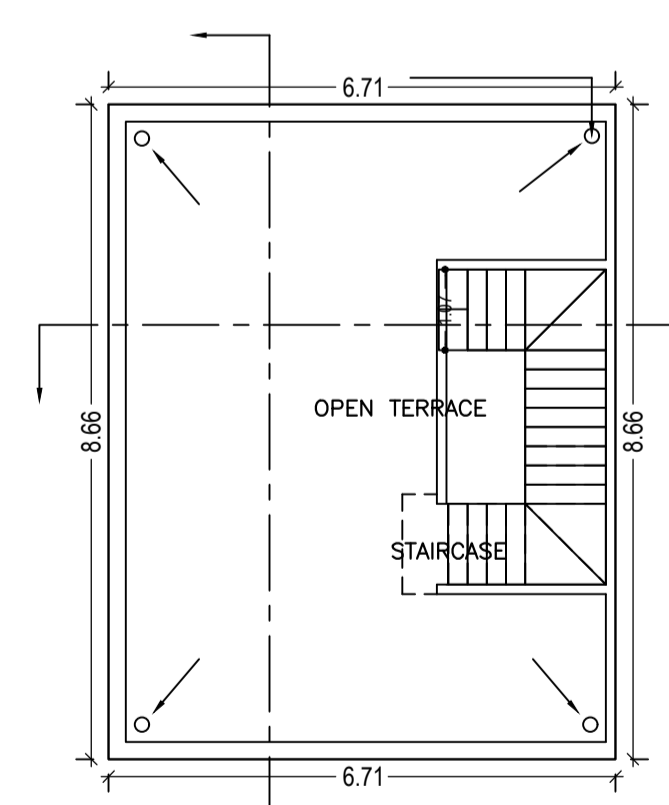

TERRACE FLOOR PLAN
(SCALE 1:100)

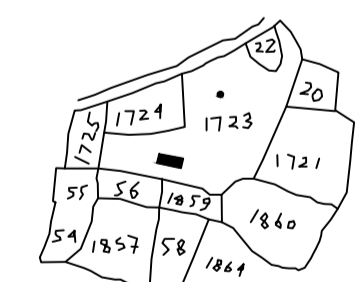

KEY PLAN
SCALE - 1" = 330'-0"

LTP NAME AND SIGNATURE	STRUCTURAL ENG'S NAME AND SIGNATURE	BUILDER NAME AND SIGNATURE
PARTHA - PAL DMC/ENG/0021/2016		