

AREA STATEMENT		VERSION NO.: 1.0.25
DHANBAD MUNICIPAL CORPORATION		VERSION DATE: 12/04/2018
PROJECT DETAIL:		
Region: JHARKHAND URBAN LOCAL BODIES	Plot Use: Residential	
District: DHANBAD	Plot SubUse: Residential Bldg/Apartment	
Authority: DHANBAD MUNICIPAL CORPORATION	Plot/Nearby/Religious/Structure: NA	
Inward No: DMC/BP/0030/W29/2018	Plot/SubPlot No: 815	
Application Type: General Proposal	North: Plot No. - 815 (p)	
Project Type: Building Permission	South: Plot No. - 814	
Nature of Development: New	East: Plot No. - 815 (p)	
Location of Development Area: Old Area	West: Road Width - 4.42	
AREA DETAILS:		
AREA OF PLOT (Minimum)	(A)	SQ.MT. 161.38
Deduction for NetPlot Area		
Surrender Free of Cost		8.10
Total		8.10
NET AREA OF PLOT(Gross Plot Area - Deduction from Gross Plot Area)	(A-Deductions)	153.28
Deduction for Balance Plot Area(from Gross Plot Area)		
Surrender Free of Cost		8.10
Common Plot		29.01
Total		37.10
BALANCE AREA OF PLOT(Net Plot Area - Recreational/Amenity space)	(A-Deductions)	124.27
PLOT AREA FOR COVERAGE(Net Plot Area)	(A-Deductions)	153.28
Plot Area for FAR (Net Plot Area + RoadWidening Area)	(A-Deductions)	161.38
COVERAGE CHECK		
Permissible Coverage area (70.00 %)		107.30
Proposed Coverage Area (57.95 %)		88.83
Total Prop. Coverage Area (57.95 %)		88.83
Balance coverage area (12.05 %)		18.47
FAR CHECK		
Permissible FAR Area (1.80)		290.48
Total Prop. FAR area		290.48
Residential FAR		177.65
Proposed FAR Area		177.65
Total Proposed FAR Area		177.65
Consumed FAR (Factor)		1.10
Balance FAR Area		112.83
BUILT UP AREA CHECK		
Total Proposed BuiltUp Area		177.66
ARCHITECT (Regd)	NISHANT KUMAR	
ENGINEER (Regd)		
SUPERVISOR (Regd)		
OWNER (Regd)	CHHOTTE LAL PANDEY	
DEVELOPMENT AUTHORITY		LOCAL BODY

COLOR INDEX	
PLOT BOUNDARY	Black
ABUTTING ROAD	Green
PROPOSED CONSTRUCTION	Red
COMMON PLOT	Yellow
ROAD WIDENING AREA	Blue
EXISTING (To be retained)	Light Blue
EXISTING (To be demolished)	Dark Blue

Buildingwise Floor FAR Details

Floor Name	Building Name A (A)		Total	
	Proposed Built Up Area (Sq.mt.)	Proposed FAR Area (Sq.mt.)	Total Proposed Built Up Area (Sq.mt.)	Total FAR Area (Sq.mt.)
Ground Floor	88.83	88.83	88.83	88.83
First Floor	88.83	88.83	88.83	88.83
Terrace Floor	0.00	0.00	0.00	0.00
Total :	177.66	177.66	177.66	177.66

Building USE/SUBUSE Details

Building Name	Building Use	Building SubUse	Building Structure
A (A)	Residential	Residential Bldg/Apartment	Non-Highrise

SCHEDULE OF DOOR:

BUILDING NAME	NAME	LENGTH	HEIGHT	NOS
A (A)	D	0.90	2.10	14

SCHEDULE OF WINDOW/VENTILATION:

BUILDING NAME	NAME	LENGTH	HEIGHT	NOS
A (A)	W	1.13	1.20	01
A (A)	W	1.20	1.20	32
A (A)	W	1.25	1.20	01
A (A)	W	2.13	1.20	02
A (A)	W	2.15	1.20	01

FAR & Tenement Details (Table 4c-1)

Building	No. of Same Bldg	Total Built Up Area (Sq.mt.)	Proposed FAR Area (Sq.mt.) Resi.	Total FAR Area (Sq.mt.)	Total Consumed Additional FAR Area (Sq.mt.)	Tnmt (No.)
A (A)	1	177.66	177.66	177.66	177.66	01
Grand Total :	1	177.66	177.66	177.66	177.66	01

SITE PLAN

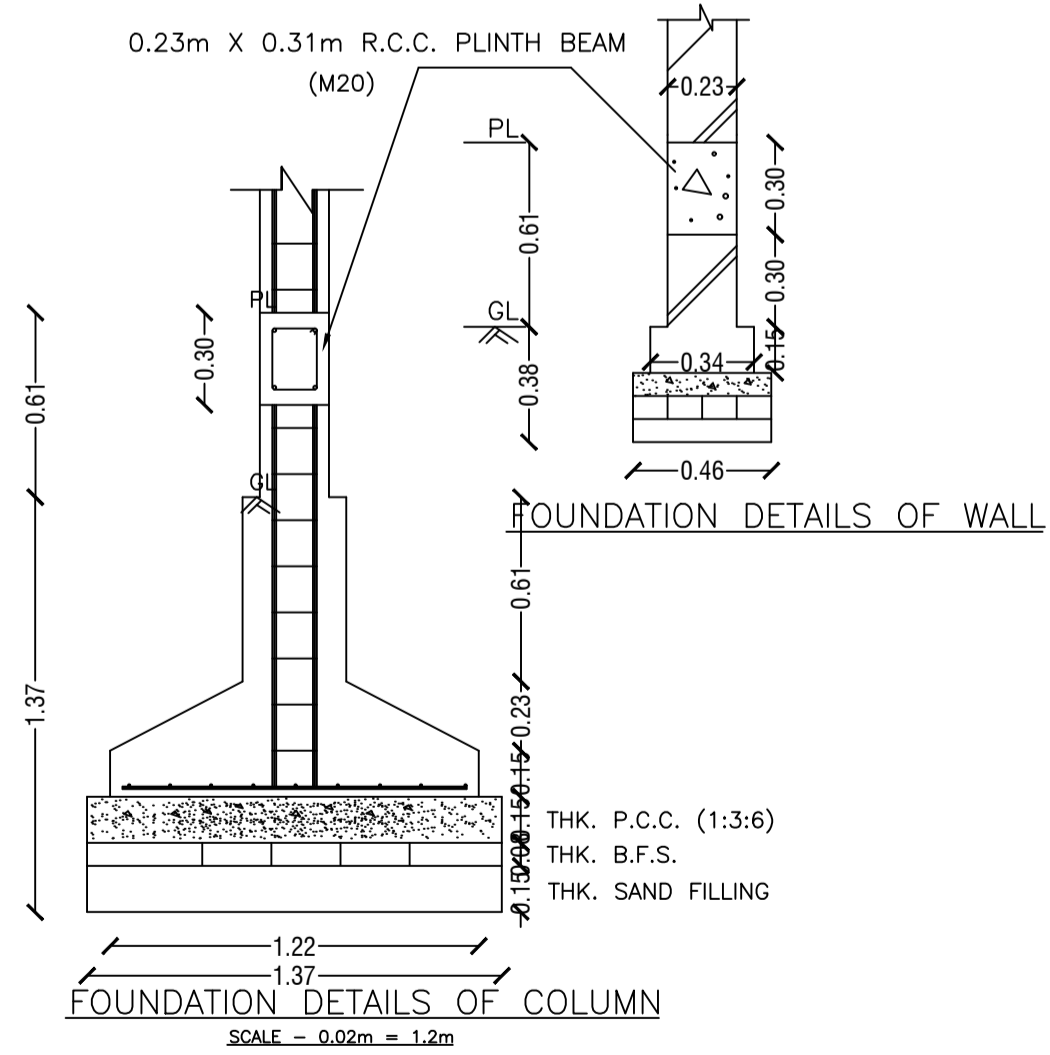
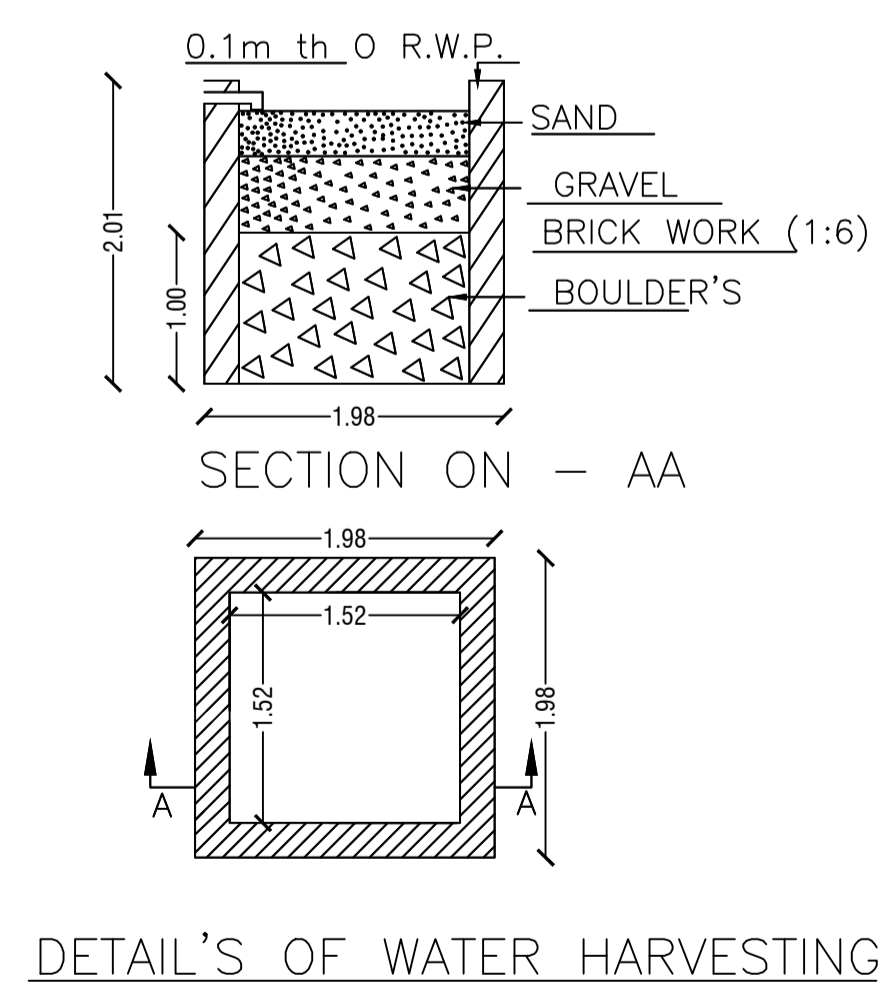
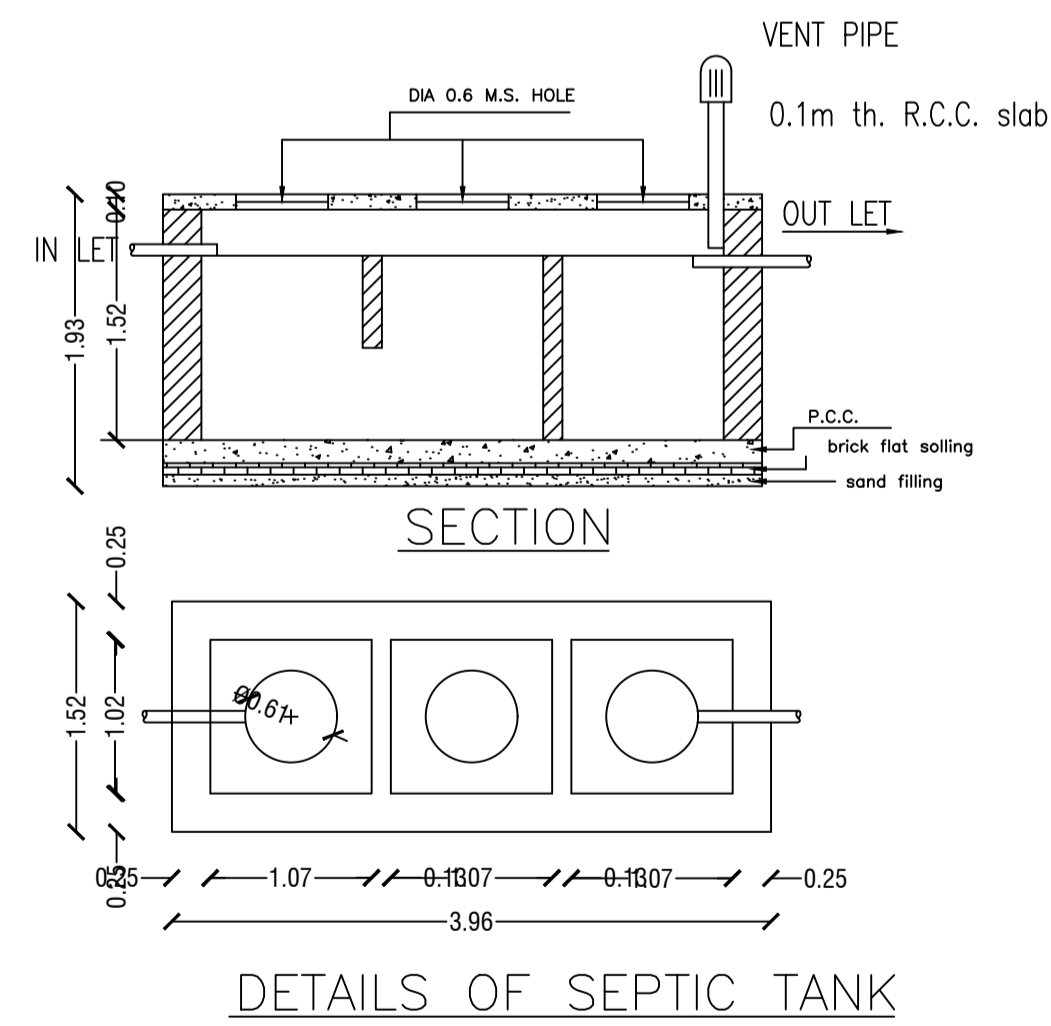
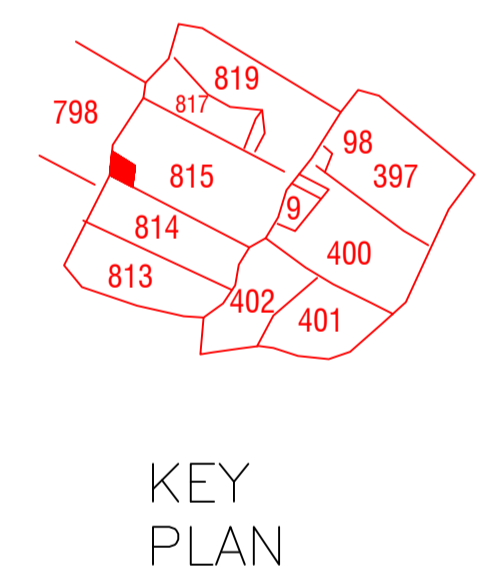

Building :A (A)

Floor Name	Total Built Up Area (Sq.mt.)	Proposed FAR Area (Sq.mt.) Resi.	Total FAR Area (Sq.mt.)	Total Consumed Additional FAR Area (Sq.mt.)	Tnmt (No.)
Ground Floor	88.83	88.83	88.83	88.83	01
First Floor	88.83	88.83	88.83	88.83	00
Terrace Floor	0.00	0.00	0.00	0.00	00
Total :	177.66	177.66	177.66	177.66	01
Total Number of Same Buildings :	1				
Total :	177.66	177.66	177.66	177.66	01

UnitBUA Table for Building :A (A)

FLOOR	Name	UnitBUA Type	UnitBUA Area	Carpet Area	No. of Rooms	No. of Tenement
GROUND FLOOR-PLAN	SPLIT 1	FLAT	177.65	177.54	8	1
FIRST FLOOR PLAN	SPLIT 1	FLAT	0.00	0.00	8	0
Total:	-	-	177.65	177.54	16	1

LTP NAME AND SIGNATURE	STRUCTURAL ENG'S NAME AND SIGNATURE	BUILDER NAME AND SIGNATURE
NISHANT KUMAR DMC/ENG/0006/2016		

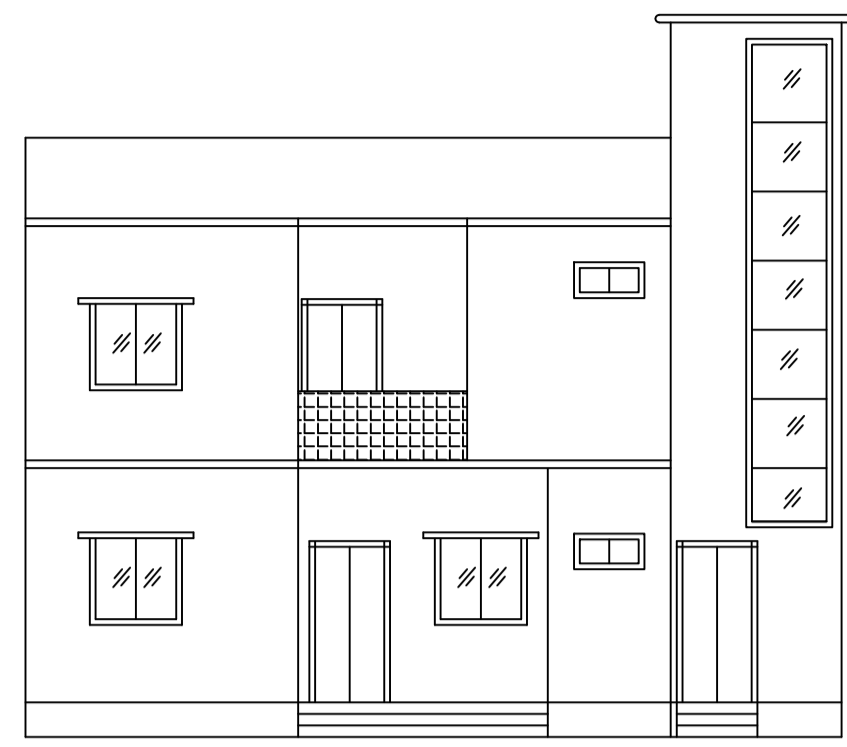

FRONT ELEVATION

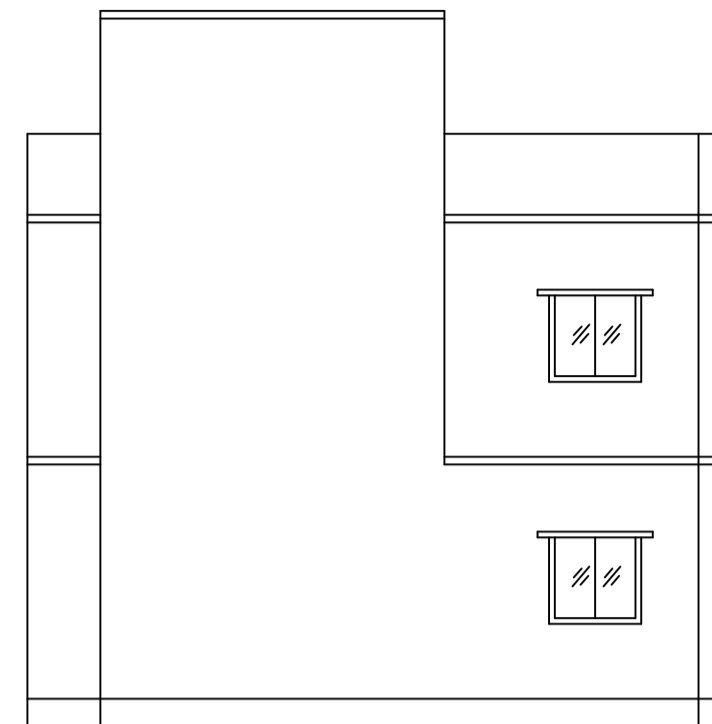

RIGHT SIDE ELEVATION

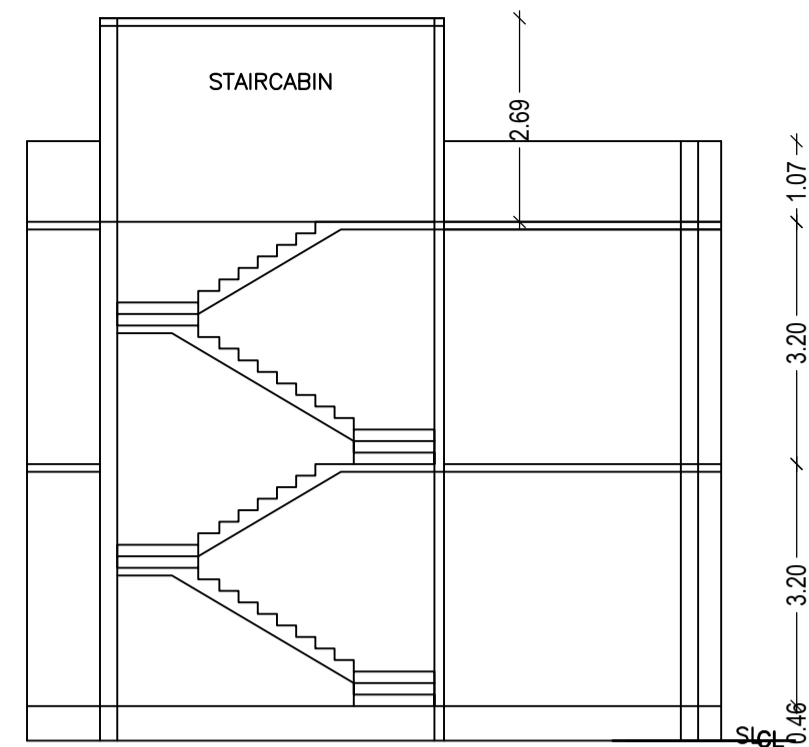

SECTION AT X-X

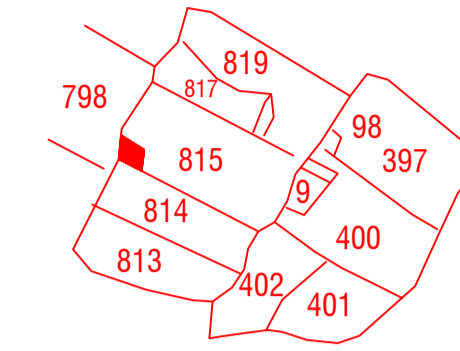

KEY PLAN

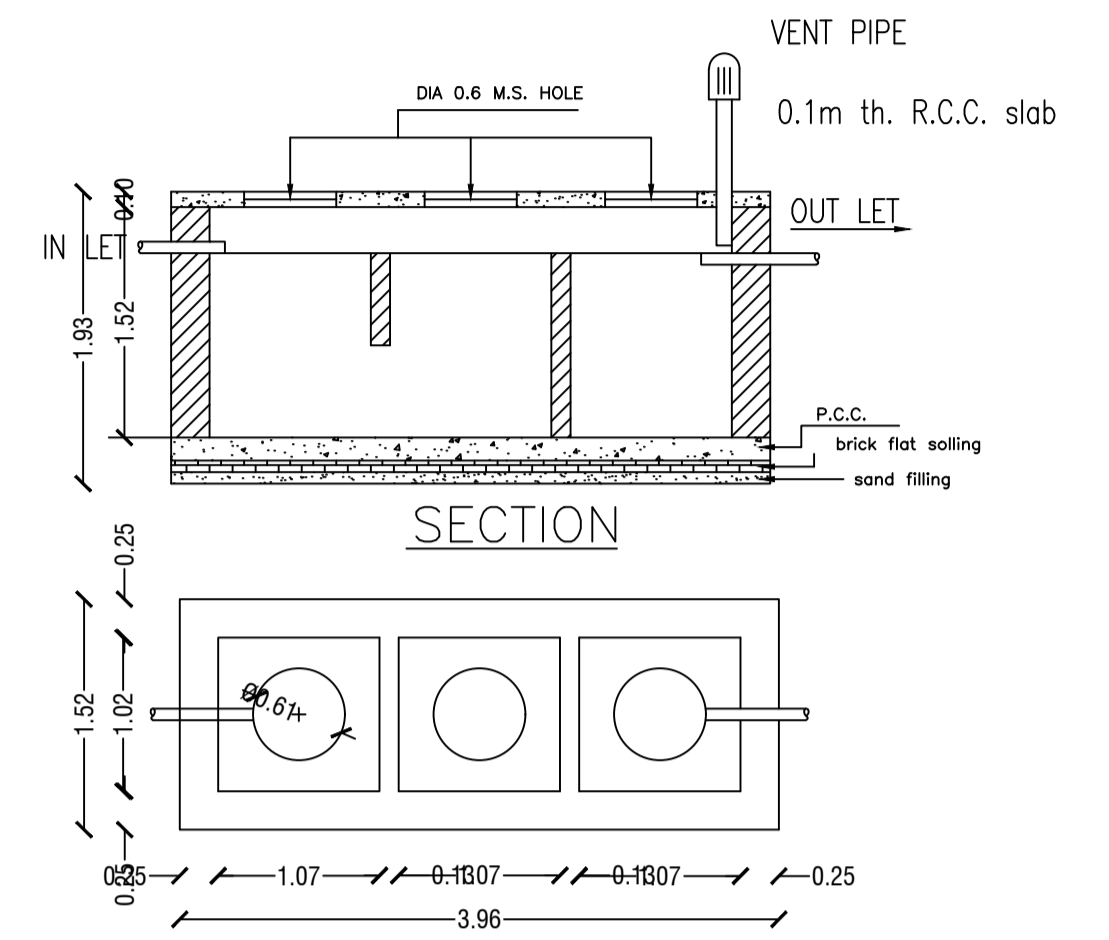

DETAILS OF SEPTIC TANK

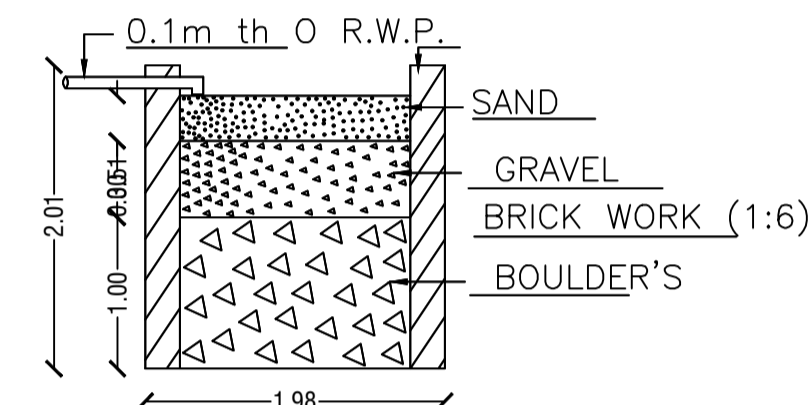

SECTION ON - AA

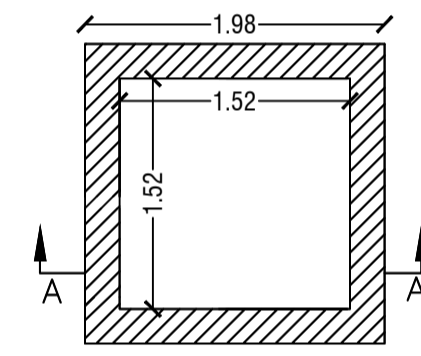

DETAIL'S OF WATER HARVESTING

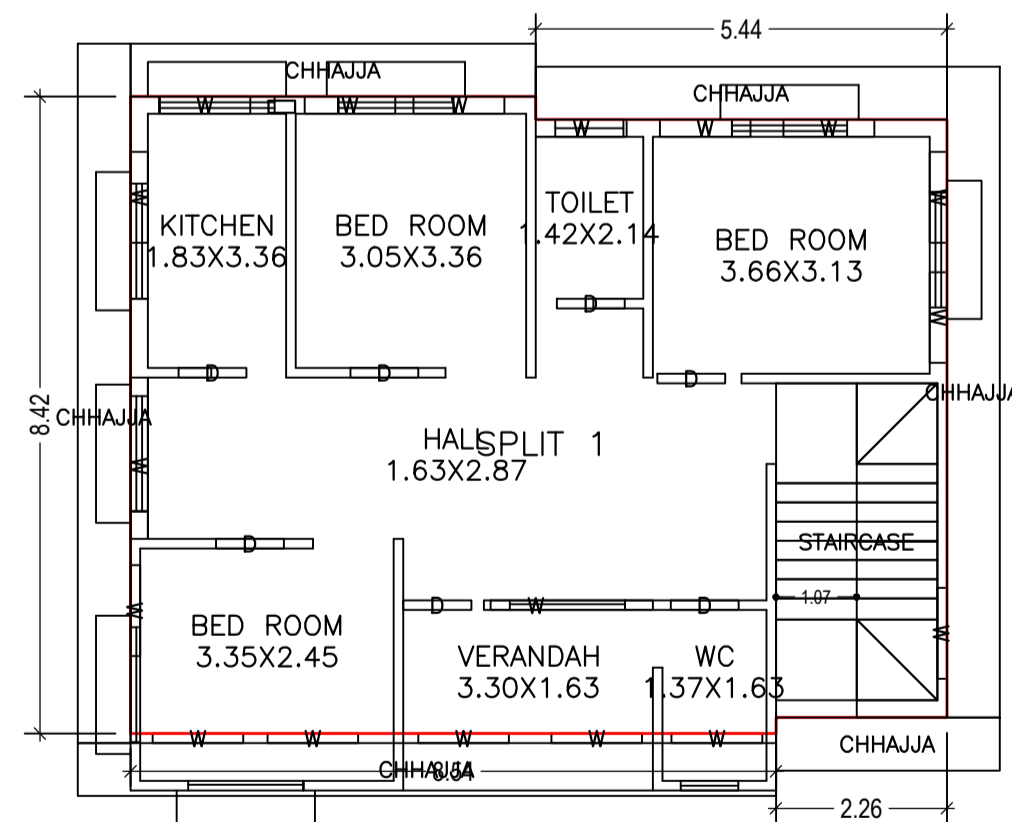

GROUND FLOOR PLAN
(Proposed)
(SCALE 1:100)

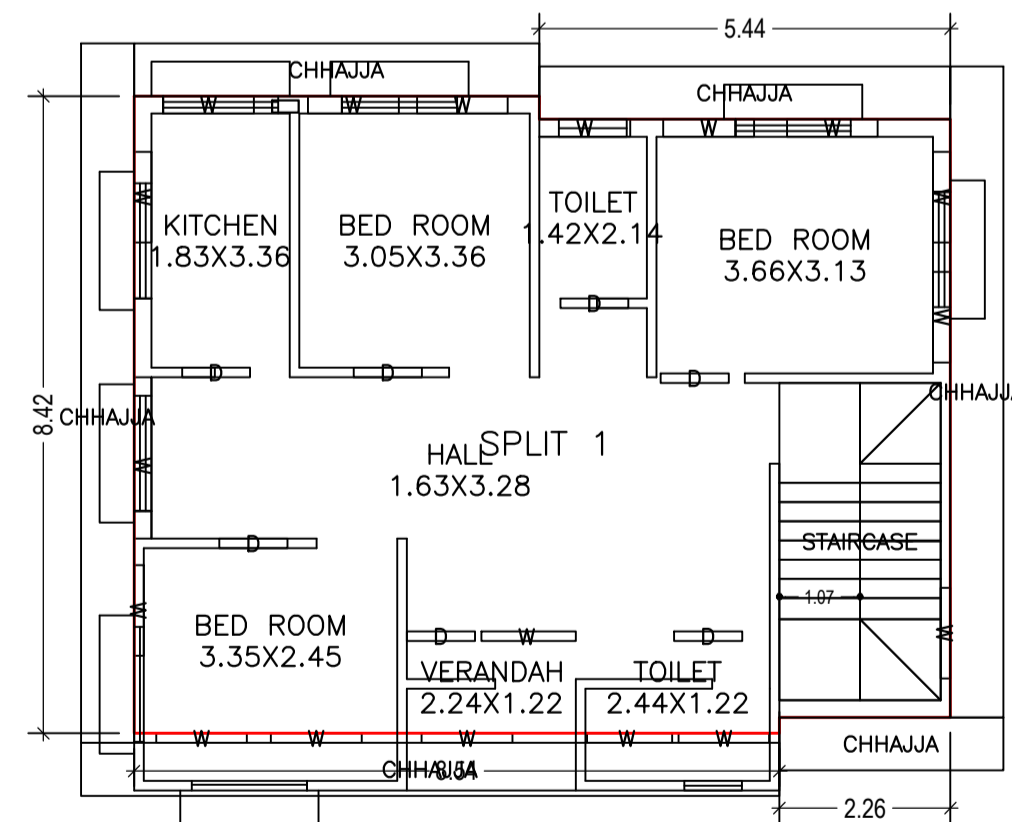

FIRST FLOOR PLAN
(Proposed)
(SCALE 1:100)

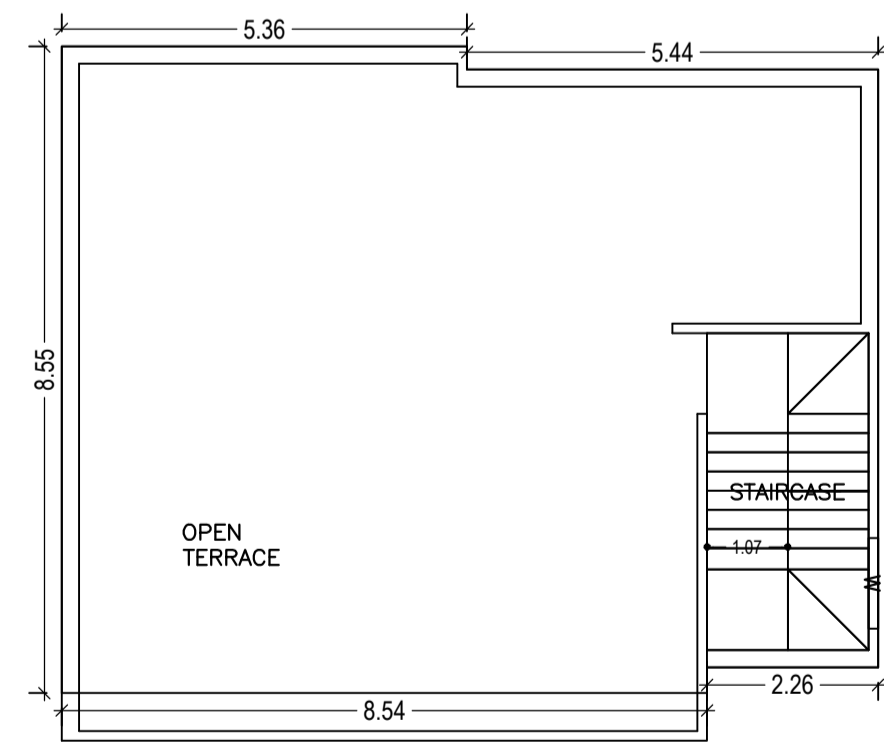

TERRACE FLOOR PLAN
(SCALE 1:100)

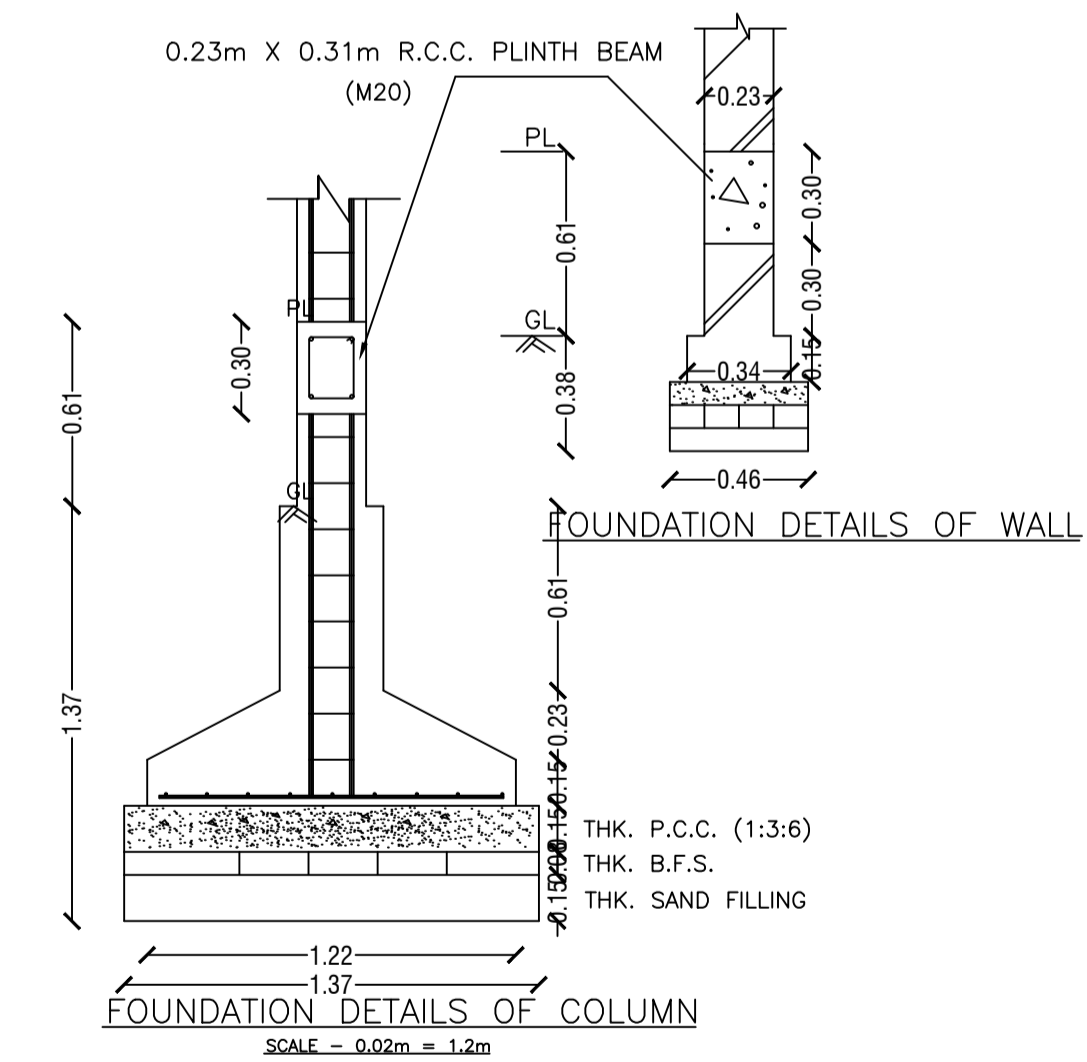

FOUNDATION DETAILS OF COLUMN

LTP NAME AND SIGNATURE	STRUCTURAL ENG'S NAME AND SIGNATURE	BUILDER NAME AND SIGNATURE
NISHANT KUMAR DMC/ENG/0006/2016		